

PRODUCT INFORMATION PACKET

marathon[®]
Motors

Model No: 513981BT-AV
Catalog No: 513981BT-AV
B-513981BT-AV BRKT MCH/318/LDG/E56/I

Regal and Marathon are trademarks of Regal Rexnord Corporation or one of its affiliated companies.
©2025 Regal Rexnord Corporation, All Rights Reserved. MC017097E

The logo for Regal Rexnord, featuring a stylized 'R' icon followed by the text 'RegalRexnord'.

Nameplate Specifications

Technical Specifications

This is an uncontrolled document once printed or downloaded and is subject to change without notice. Date Created:04/05/2025

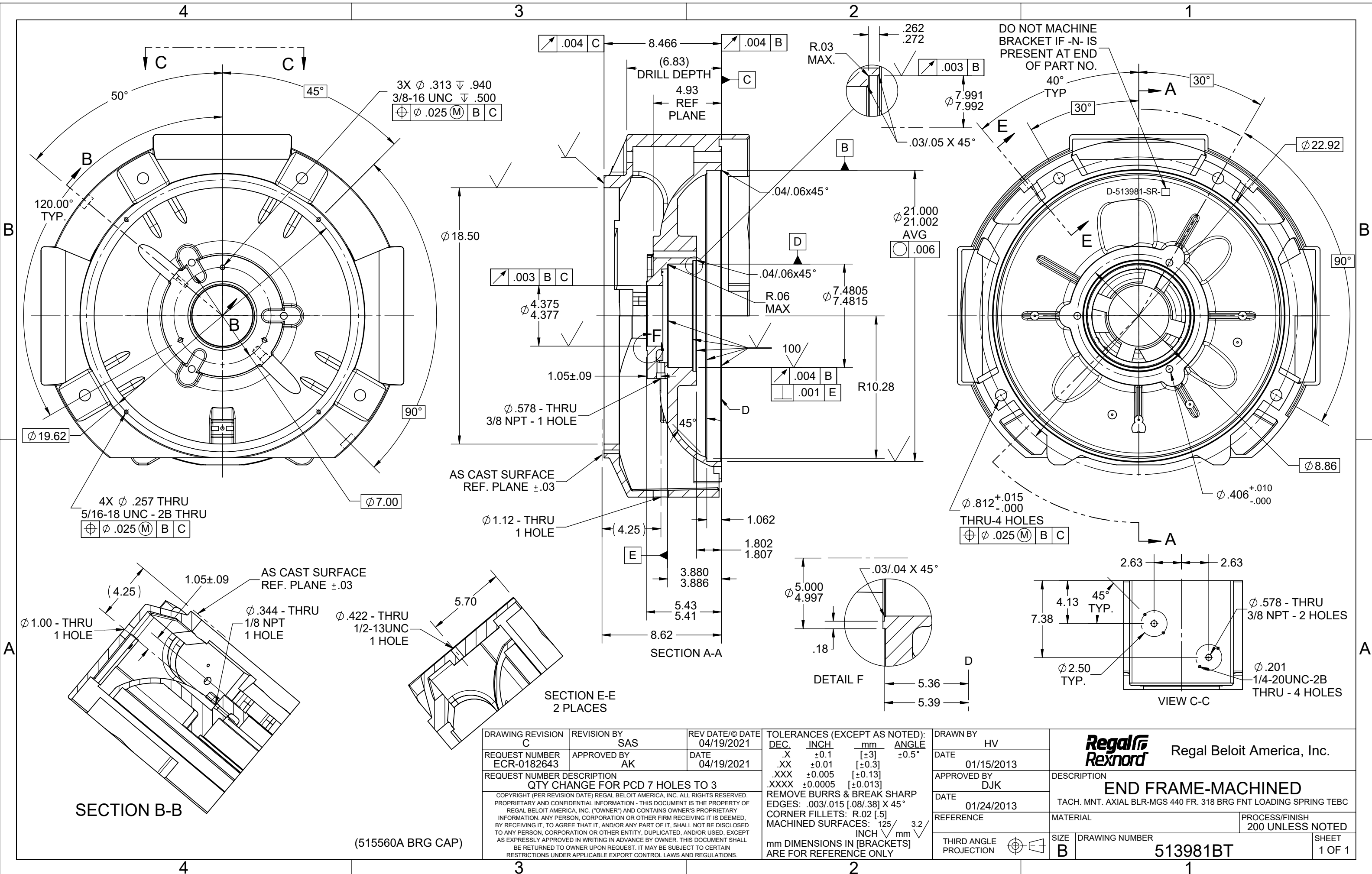

DRAWING REVISION C	REVISION BY SAS	REV DATE/© DATE 04/19/2021	TOLERANCES (EXCEPT AS NOTED): DEC. INCH mm ANGLE .X ±0.1 [±3] ±0.5° .XX ±0.01 [±0.3] .XXX ±0.005 [±0.13] .XXXX ±0.0005 [±0.013]	DRAWN BY HV	Regal Beloit America, Inc.		
REQUEST NUMBER ECR-0182643	APPROVED BY AK	DATE 04/19/2021	REMOVE BURRS & BREAK SHARP EDGES: .003/.015 [.08/.38] X 45° CORNER FILLETS: R.02 [.5] MACHINED SURFACES: 125 $\sqrt{\text{INCH}}$ / 3.2 $\sqrt{\text{mm}}$ mm DIMENSIONS IN [BRACKETS] ARE FOR REFERENCE ONLY	DATE 01/15/2013			
REQUEST NUMBER DESCRIPTION QTY CHANGE FOR PCD 7 HOLES TO 3				APPROVED BY DJK	DESCRIPTION END FRAME-MACHINED		
COPYRIGHT (PER REVISION DATE) REGAL BELOIT AMERICA, INC. ALL RIGHTS RESERVED. PROPRIETARY AND CONFIDENTIAL INFORMATION - THIS DOCUMENT IS THE PROPERTY OF REGAL BELOIT AMERICA, INC. ("OWNER") AND CONTAINS OWNER'S PROPRIETARY INFORMATION. ANY PERSON, CORPORATION OR OTHER FIRM RECEIVING IT IS DEEMED, BY RECEIVING IT, TO AGREE THAT IT, AND/OR ANY PART OF IT, SHALL NOT BE DISCLOSED TO ANY PERSON, CORPORATION OR OTHER ENTITY, DUPLICATED, AND/OR USED, EXCEPT AS EXPRESSLY APPROVED IN WRITING IN ADVANCE BY OWNER. THIS DOCUMENT SHALL BE RETURNED TO OWNER UPON REQUEST. IT MAY BE SUBJECT TO CERTAIN RESTRICTIONS UNDER APPLICABLE EXPORT CONTROL LAWS AND REGULATIONS.				DATE 01/24/2013	TACH. MNT. AXIAL BLR-MGS 440 FR. 318 BRG FNT LOADING SPRING TEBC		
				REFERENCE	MATERIAL	PROCESS/FINISH 200 UNLESS NOTED	
				THIRD ANGLE PROJECTION	SIZE B	DRAWING NUMBER 513981BT	SHEET 1 OF 1

(515560A BRG CAP)