

# PRODUCT INFORMATION PACKET

**marathon**<sup>®</sup>  
Motors

Model No: 531871B-Y  
Catalog No: 531871B-Y  
B-531871B-Y (DE) BRG CARTRIDGE PMACH (322BRG)

Regal and Marathon are trademarks of Regal Rexnord Corporation or one of its affiliated companies.  
©2025 Regal Rexnord Corporation, All Rights Reserved. MC017097E

The logo for Regal Rexnord, featuring a stylized 'R' icon followed by the text 'RegalRexnord'.

Nameplate Specifications

Technical Specifications

This is an uncontrolled document once printed or downloaded and is subject to change without notice. Date Created:04/05/2025

4X Ø.20  $\nabla$  .75  
1/4-20 UNC - 2B  $\nabla$  .50

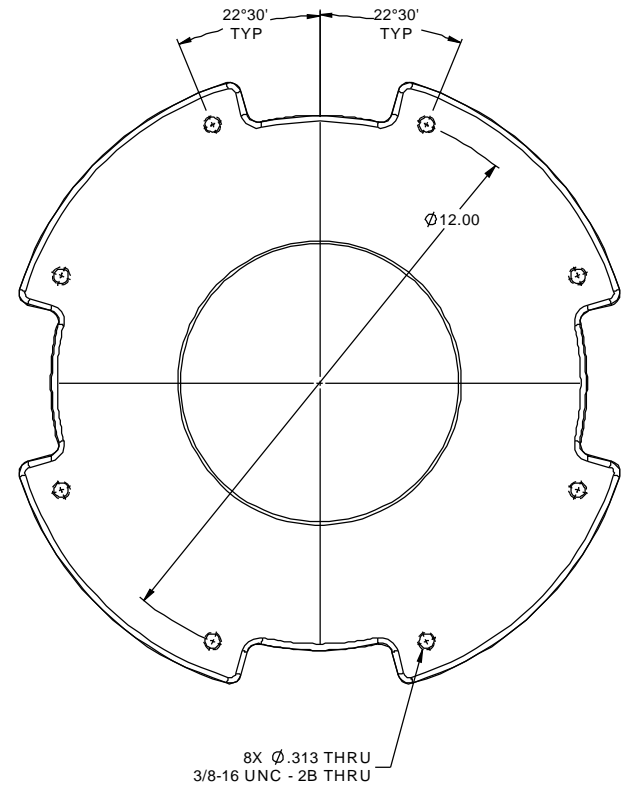
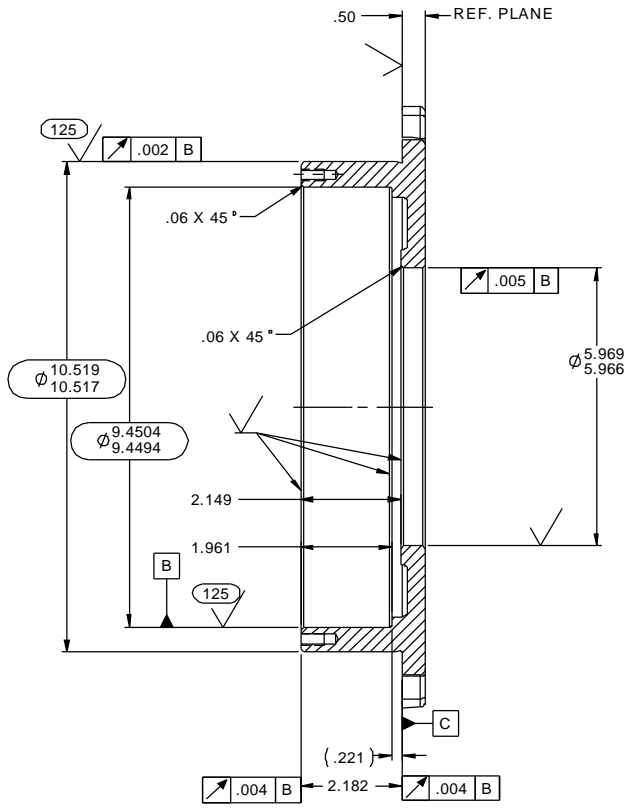
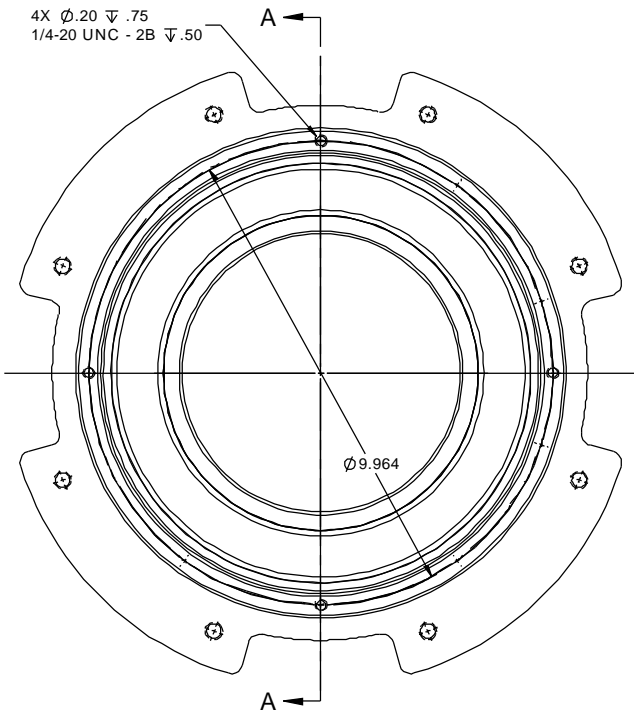

SECTION A-A

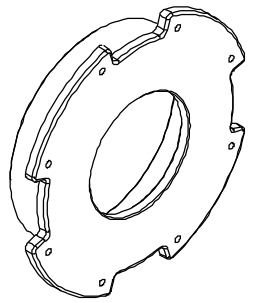

TOLERANCES UNLESS SPECIFIED		REGAL-BELOIT CORPORATION		DRAWN CDP 10-10-2011	
DEC	INCHES	CHK	TJW 10-12-2011	APPR	JER 10-12-2011
X	±.1				
3	ISAAC:12-5749 CHANGED BEARING BORE DEPTH TO 1.961	CDP 12/3/2012	JER xxx ±.02	TITLE BEARING CARTRIDGE MACHINING (DE)	
2	ISAAC:12-0237 REMOVED O-RING GROOVE	CDP 02-03-2012	xxx ±.005	740FR -MARINE DEP / TEWAC	
1	ISAAC:12-0237 ADDED O-RING GROOVE	CDP 02-01-2012	TJW xxxxx ±.0005	MAT'L	
NO	REVISION	BY & DATE	CHK ANG ±7°30'	FINISH 200 MAX SURFACE ROUGHNESS UNLESS NOTED	
	THIRD ANGLE PROJECTION		RFP 10-13-2011	PREV	
			NETWORK FILE NAME 531871B	SIZE B	DRAWING NO 531871B
				PAGE 1 OF 1	REV 3