

PRODUCT INFORMATION PACKET



Model No: TO102
Catalog No: TO102
General Purpose Motor, 1 HP, 3 Ph, 60 Hz, 575 V, 1800 RPM, 143T Frame, ODP



Regal and Century are trademarks of Regal Rexnord Corporation or one of its affiliated companies.
©2022 Regal Rexnord Corporation, All Rights Reserved. MC017097E





Nameplate Specifications

Output HP	1 Hp	Output KW	0.75 kW
Frequency	60 Hz	Voltage	575 V
Current	1.1 A	Speed	1748 rpm
Service Factor	1.15	Phase	3
Duty	Continuous	Insulation Class	F
Frame	143T	Enclosure	Open Drip Proof
Thermal Protection	No Protection	Ambient Temperature	40 °C
UL	Recognized	CSA	Y
CE	Y	Number of Speeds	1

Technical Specifications

Electrical Type	POLYPHASE	Starting Method	Across The Line
Poles	4	Rotation	Reversible
Mounting	Rigid Base	Drive End Bearing	Ball
Opp Drive End Bearing	Ball	Frame Material	Rolled Steel
Shaft Type	Keyed	Overall Length	11.20 in
Frame Length	5.75 in	Shaft Diameter	0.875 in
Shaft Extension	2.25 in		
Connection Drawing	A-EE7300	Outline Drawing	TO102-S01

This is an uncontrolled document once printed or downloaded and is subject to change without notice. Date Created:11/29/2022

REV	ECO	REV BY	DATE	APPD	DATE
B	0038030	G.ZHAO	09-10-2013	B.SHEN	09-10-2013

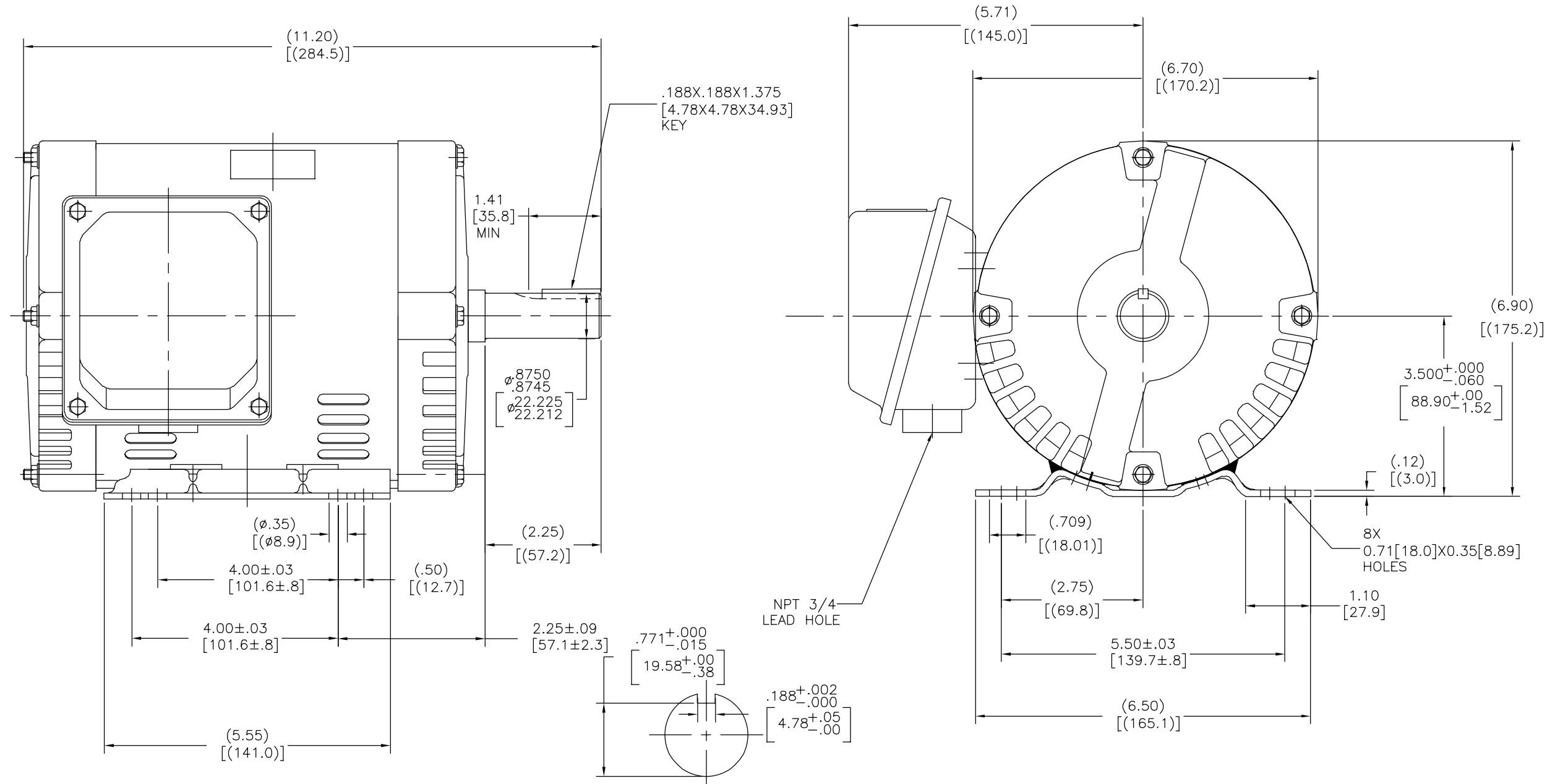

GEOMETRIC CHARACTERISTICS & SYMBOLS

- FLATNESS
- STRAIGHTNESS
- ANGULARITY
- PERPENDICULARITY (SQUARENESS)
- PARALLELISM
- ROUNDNESS (CIRCULARITY)
- CYLINDRICITY
- PROFILE OF ANY SURFACE
- PROFILE OF ANY LINE
- RUNOUT
- TRUE POSITION
- CONCENTRICITY
- SYMMETRY

ASME Y14.5M 1994

UNLESS OTHERWISE SPECIFIED DIM. TOLERANCES ARE AS FOLLOWS:

INCH	$\pm .1$	$\pm .02$	$\pm .005$	$\pm .0005$
mm	± 0.5	± 0.13	± 0.013	

ANG. ± 50 DEG
 REMOVE BURRS & BREAK SHARP EDGES:
 INCH .003-.015 mm 0.1-0.4
 CORNER FILLETS TO:
 INCH .020 mm 0.5
 MACHINE SURFACES:
 INCH 125 mm 3.2

METRIC DIMS. SHOWN IN [BRACKETS]

DR BY: A.NAJERA 10-18-2012

APPD: D.JAMORA 10-18-2012

THIRD ANGLE PROJECTION

EDS DATE 11-11-2011
 FORMAT REV H

CONFIDENTIAL: THIS DRAWING AND ITS INFORMATION ARE THE EXCLUSIVE AND CONFIDENTIAL PROPERTY OF REGAL-BELOIT CORPORATION AND ARE NOT TO BE DISCLOSED, DUPLICATED, DISTRIBUTED OR OTHERWISE USED WITHOUT THE WRITTEN CONSENT OF REGAL-BELOIT CORPORATION. -ALL RIGHTS RESERVED.

REGAL REGAL-BELOIT CORPORATION

DESCRIPTION: MODEL-IHP OUTLINE

SIZE: C DWG NO: T0102

SCALE: NONE SHEET: 1

REVISION:	ECO	REVISADO POR:	FECHA:	APROBADO POR:	FECHA:
B	0038030	G.ZHAO	09-10-2013	B.SHEN	09-10-2013

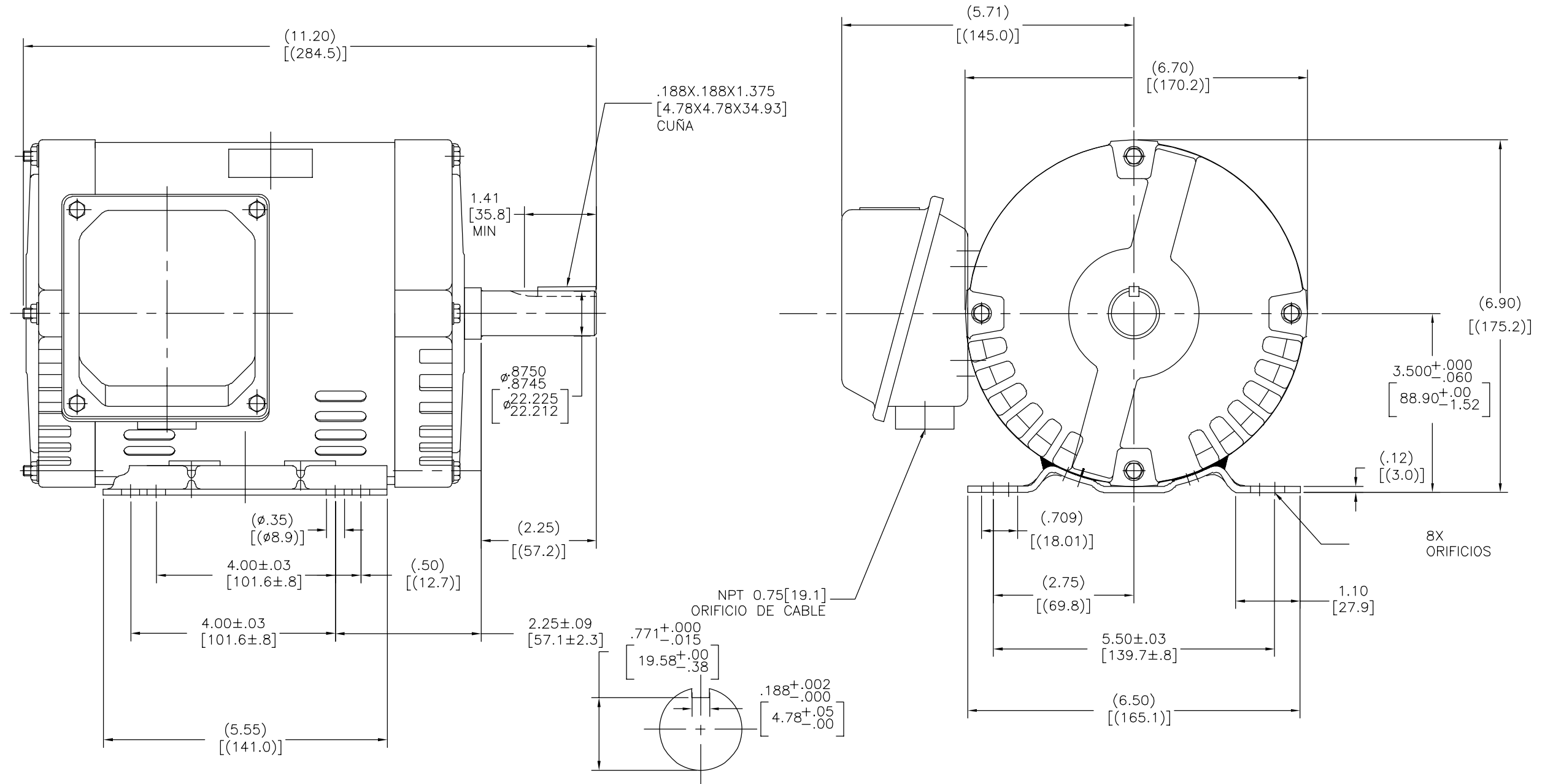

CARACTERISTICAS DE GEOMETRIA Y SIMBOLOS ▽ PLANICIDAD — RECTITUD ∠ ANGULARIDAD ⊥ PERPENDICULARIDAD (A ESCUADRA) // PARALELISMO ○ REDONDEZ (CIRCULARIDAD) ⌀ CILINDRICIDAD △ PERFIL DE CUALQUIER SUPERFICIE ▽ PERFIL DE CUALQUIER LINEA ↗ VARIACION ⊕ POSICION REAL ⊙ CONCENTRICIDAD = SIMETRIA ASME Y14.5M 1994	A MENOS QUE SE ESPECIFIQUE DE OTRA MANERA, LAS TOLERANCIAS DE LAS DIMS; SON LAS SIGUIENTES: PULG ±.1 ±.02 ±.005 ±.0005 mm ±0.5 ±0.13 ±0.013 ANG. ± 50 GRADOS ELIMINAR REBABAS Y ORILLAS FILOSAS DEL BORDE. PULG .003-.015 mm 0.1-0.4 FILETEAR ESQUINA: PULG .020 mm 0.5 MAQUINAR SUPERFICIES PULG 125 mm 3.2 DIMS METRICAS MOSTRADAS [PARENTESIS]	DIBUJADO POR: A.NAJERA 10-18-2012	REGAL REGAL-BELOIT CORPORATION
		APROBADO POR: D.JAMORA 10-18-2012	
		TERCER ANGULO DE PROYECCION	FECHA EDS: 11-11-2011 REV. FORMATO: H
		CONFIDENCIAL: ESTE DIBUJO Y SU INFORMACION SON PROPIEDAD DE USO EXCLUSIVO Y CONFIDENCIAL DE REGAL-BELOIT CORPORATION. Y NO DEBERAN SER REVELADOS, DUPLICADOS, DISTRIBUIDOS O USARSE DE OTRA MANERA SIN EL CONSENTIMIENTO ESCRITO DE REGAL-BELOIT CORPORATION. -TODOS LOS DERECHOS RESERVADOS.	
		TAMAÑO: C	NUMERO DE DIBUJO: T0102
		ESCALA:NONE	HOJA: 1

THREE PHASE - SINGLE VOLTAGE
MOTOR - CONDUIT BOX @ 'A'

TERMINAL BLOCK WHEN SPECIFIED

TO REVERSE ROTATION:
INTERCHANGE ANY TWO LINE
LEAD CONNECTIONS

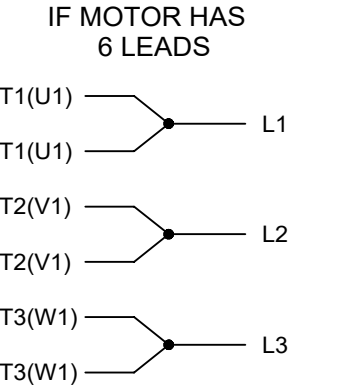
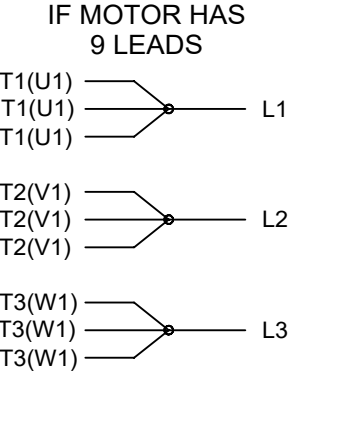

A-9806 DECAL

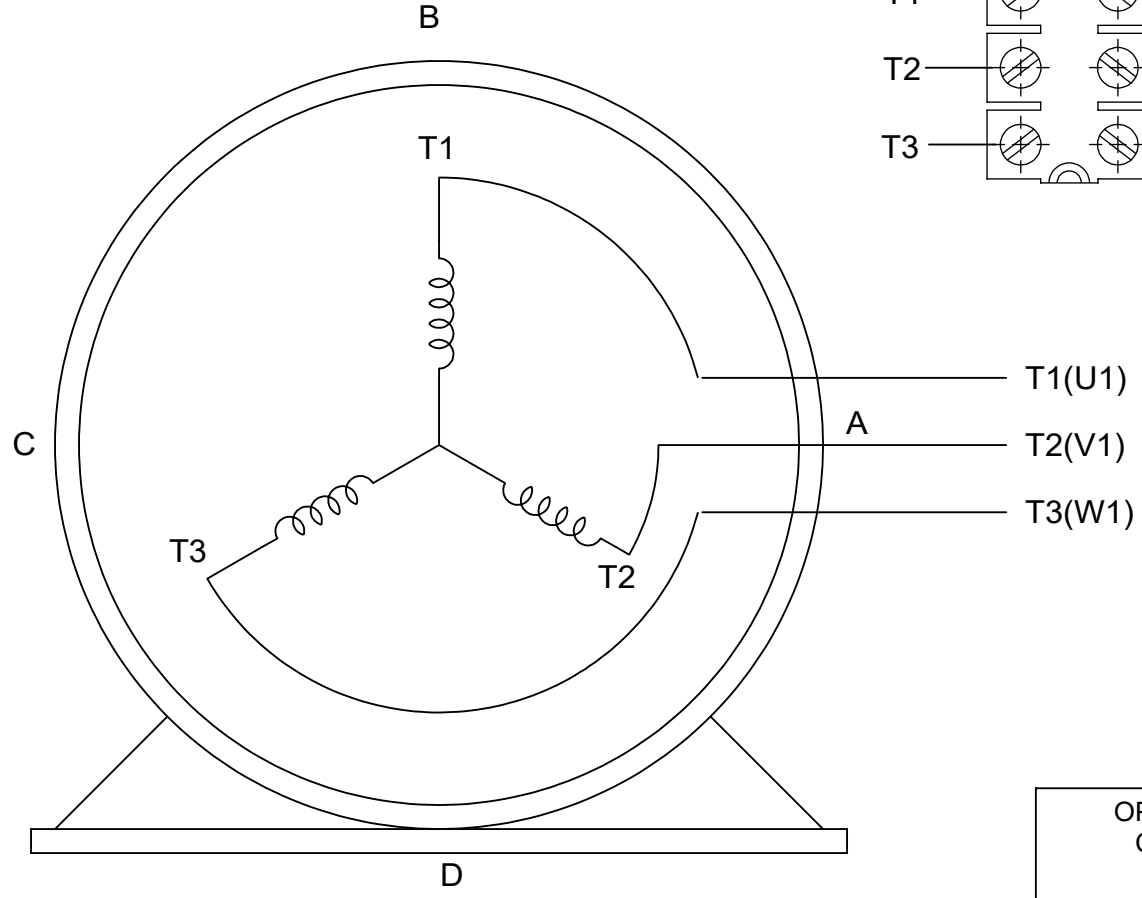

VIEW OF TERMINAL END

OPTIONAL CORD CONNECTION

L1	WHITE
L2	RED
L3	BLACK

DRAWING REVISION AC	REVISION BY BS	REV DATE/© DATE 26/07/2022
REQUEST NUMBER CR-0010402	APPROVED BY SN	DATE 26/07/2022

PRIMARY DIMENSIONS ARE INCH
mm DIMENSIONS IN [BRACKETS]
ARE FOR REFERENCE ONLY

DRAWN BY DA
DATE 03-26-1993
APPROVED BY TB
DATE 03-26-1993
REFERENCE
THIRD ANGLE PROJECTION

		Regal Beloit America, Inc.	
DESCRIPTION CONNECTION DIAGRAM EXTERNAL - SINGLE VOLTAGE - 3Ø MOTOR			
MATERIAL		PROCESS/FINISH	
SIZE A	DRAWING NUMBER EE7300	SHEET 1 OF 1	

REQUEST NUMBER DESCRIPTION
DRAWING UPDATED

COPYRIGHT (PER REVISION DATE) REGAL BELOIT AMERICA, INC. ALL RIGHTS RESERVED. PROPRIETARY AND CONFIDENTIAL INFORMATION - THIS DOCUMENT IS THE PROPERTY OF REGAL BELOIT AMERICA, INC. ("OWNER") AND CONTAINS OWNER'S PROPRIETARY INFORMATION. ANY PERSON, CORPORATION OR OTHER FIRM RECEIVING IT IS DEEMED, BY RECEIVING IT, TO AGREE THAT IT, AND/OR ANY PART OF IT, SHALL NOT BE DISCLOSED TO ANY PERSON, CORPORATION OR OTHER ENTITY, DUPLICATED, AND/OR USED, EXCEPT AS EXPRESSLY APPROVED IN WRITING IN ADVANCE BY OWNER. THIS DOCUMENT SHALL BE RETURNED TO OWNER UPON REQUEST. IT MAY BE SUBJECT TO CERTAIN RESTRICTIONS UNDER APPLICABLE EXPORT CONTROL LAWS AND REGULATIONS.