

PRODUCT INFORMATION PACKET

marathon®
Motors

Model No: TCM0551A2113GAC011

Catalog No: TCM0551A2113GAC011

TerraMAX® IE3, Mining Duty Motors, 55 kW, 3Ph, 2 Pole, 400/690V, B3, 50Hz, 250M Frame, TEFC

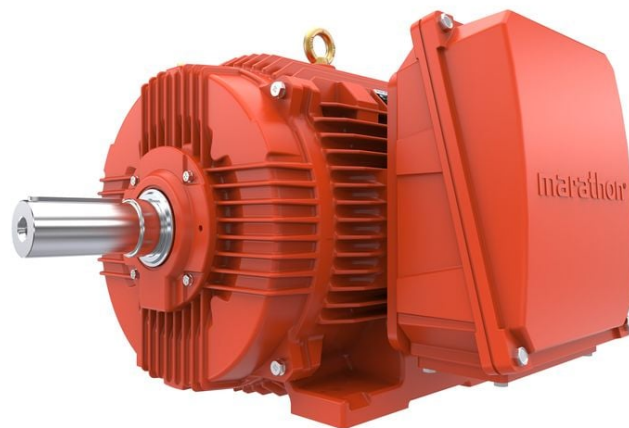

Regal and Marathon are trademarks of Regal Rexnord Corporation or one of its affiliated companies.

©2022 Regal Rexnord Corporation, All Rights Reserved. MC017097E

RegalRexnord

Nameplate Specifications

Output HP	75 Hp	Output KW	55.0 kW
Frequency	50 Hz	Voltage	400/690 V
Current	94.6 A	Speed	2977 rpm
Service Factor	1	Phase	3
Efficiency	94.3 %	Power Factor	0.89
Duty	S1	Insulation Class	H
Frame	250M	Enclosure	Totally Enclosed Fan Cooled
Thermal Protection	No Protection	Ambient Temperature	40 °C
Drive End Bearing Size	6314	Opp Drive End Bearing Size	6314
UL	NO	CSA	NO
CE	YES	IP Code	66
Number of Speeds	1	Efficiency Class	IE3

Technical Specifications

Electrical Type	Squirrel Cage	Starting Method	Direct On Line
Poles	2	Rotation	Bi-Directional
Mounting	B3	Motor Orientation	Horizontal
Drive End Bearing	C3	Opp Drive End Bearing	C3
Frame Material	Cast Iron	Shaft Type	Keyed
Overall Length	941 mm	Frame Length	460 mm
Shaft Diameter	60 mm	Shaft Extension	140 mm
Assembly/Box Mounting	RHS		
Outline Drawing	0225000680	Connection Drawing	8442000086

This is an uncontrolled document once printed or downloaded and is subject to change without notice. Date Created:12/02/2022

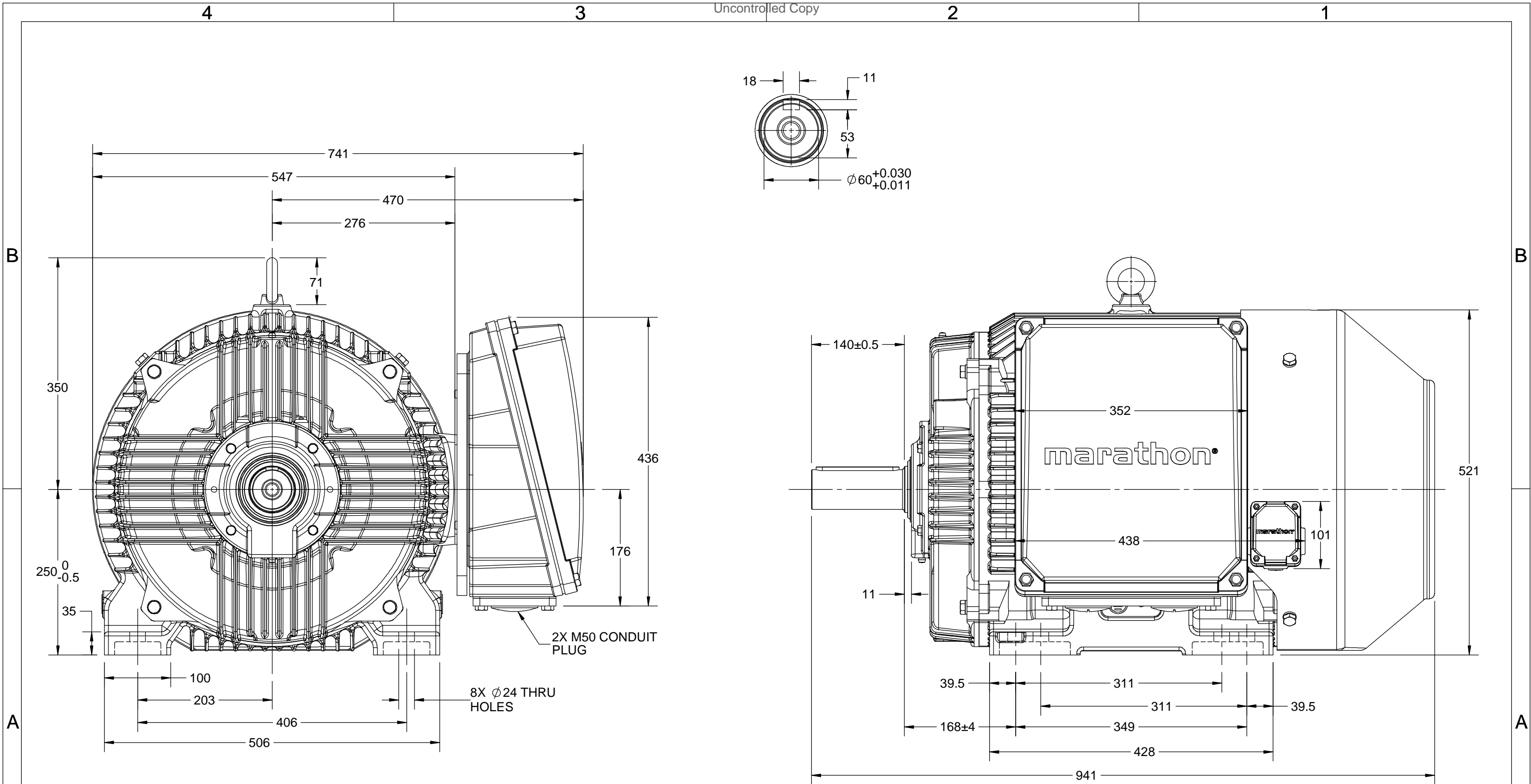

DRAWING REVISION B	REVISION BY LK	DATE 31/07/2018
ECO ECO-0149394	APPROVED BY SBD	DATE 31/07/2018
ECO DESCRIPTION MODEL UPDATED WITH NEW STRUCTURE		
<small>COPYRIGHT REGAL BELOIT AMERICA, INC. ALL RIGHTS RESERVED. PROPRIETARY AND CONFIDENTIAL INFORMATION - THIS DOCUMENT IS THE PROPERTY OF REGAL BELOIT AMERICA, INC. ("OWNER") AND CONTAINS OWNER'S PROPRIETARY INFORMATION. ANY PERSON, CORPORATION OR OTHER FIRM RECEIVING IT IS DEEMED, BY RECEIVING IT, TO AGREE THAT IT, AND/OR ANY PART OF IT, SHALL NOT BE DISCLOSED TO ANY PERSON, CORPORATION OR OTHER ENTITY, DUPLICATED, AND/OR USED, EXCEPT AS EXPRESSLY APPROVED IN WRITING IN ADVANCE BY OWNER. THIS DOCUMENT SHALL BE RETURNED TO OWNER UPON REQUEST. IT MAY BE SUBJECT TO CERTAIN RESTRICTIONS UNDER APPLICABLE EXPORT CONTROL LAWS AND REGULATIONS.</small>		

DRAWN BY LK	 OUTLINE 250FR-2P-B3 MTG. MOTOR TYPE: TCM	
DATE 21/12/2017		
APPROVED BY SBD	DESCRIPTION	
DATE 21/12/2017	MATERIAL	
REFERENCE	DRAWING NUMBER 0225000680	PROCESS/FINISH
THIRD ANGLE PROJECTION	SIZE B	SHEET 1 OF 1

Copyrighted Copy
 COPYRIGHT REGAL BELOIT AMERICA, INC. ALL RIGHTS RESERVED.
 PROPRIETARY AND CONFIDENTIAL INFORMATION - THIS DOCUMENT IS THE PROPERTY OF
 REGAL BELOIT AMERICA, INC. ("OWNER") AND CONTAINS OWNER'S PROPRIETARY
 INFORMATION. ANY PERSON, CORPORATION OR OTHER FIRM RECEIVING IT IS DEEMED,
 BY RECEIVING IT, TO AGREE THAT IT, AND/OR ANY PART OF IT, SHALL NOT BE DISCLOSED
 TO ANY PERSON, CORPORATION OR OTHER ENTITY, DUPLICATED, AND/OR USED, EXCEPT
 AS EXPRESSLY APPROVED IN WRITING IN ADVANCE BY OWNER. THIS DOCUMENT SHALL
 BE RETURNED TO OWNER UPON REQUEST. IT MAY BE SUBJECT TO CERTAIN
 RESTRICTIONS UNDER APPLICABLE EXPORT CONTROL LAWS AND REGULATIONS.

DRAWING REVISION A	REVISION BY SN	DATE 13/01/2016
ECO ECO-0116390	APPROVED BY SBD	DATE 13/01/2016
ECO DESCRIPTION NEW DRAWING RELEASE		

GENERAL TOLERANCE		
LINEAR DIM	>0~6	±0.1
	>6~30	±0.2
	>30~120	±0.3

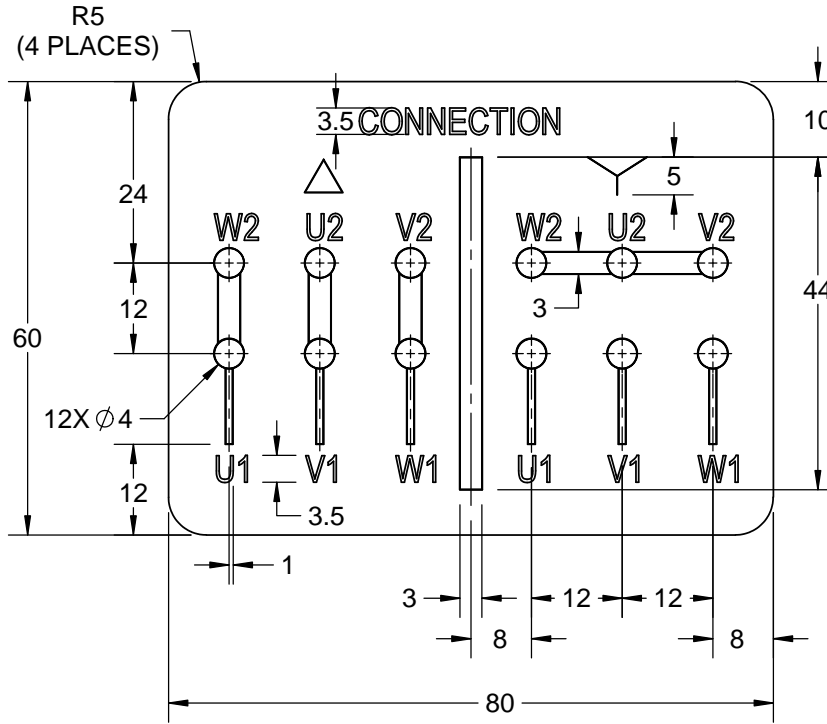

NOTES:

1. PRESSURE-SENSITIVE ADHESIVE TAPE COATED WITH ANTI-ADHESIVE.
2. AT THE END OF YELLOW, WORDS, SYMBOLS, LETTERS ARE BLACK.
3. THE TOLERANCE OF THE LINEAR SIZE OF THE TOLERANCE WITHOUT THE TOLERANCE BY THE TABLE.

8WD.864.1008

	DRAWN BY SN		Regal Beloit America, Inc.
	DATE 16/12/2016		
	APPROVED BY SBD		DESCRIPTION CONN DIAGRAM-NAMEPLATE
	DATE 16/12/2016		
	REFERENCE	MATERIAL	
THIRD ANGLE PROJECTION	SIZE A	DRAWING NUMBER 8442000086	SHEET 1 OF 1

Model No. TCM0551A2113GAC011

U (V)	Δ / Y Conn	f [Hz]	P		I [A]	n [RPM]	T [Nm]	IE Class	% EFF at __ load				PF at __ load			I_A/I_N [pu]	T_A/T_N [pu]	T_K/T_N [pu]
			[kW]	[hp]					5/4FL	FL	3/4FL	1/2FL	FL	3/4FL	1/2FL			
400	Δ	50	55	75	94.6	2977	179.37	IE3	-	94.3	94.3	93	0.89	0.86	0.78	7	1.9	3.4

Motor type	TCM	Degree of protection	IP 66
Enclosure	TEFC	Mounting type	IM B3
Frame Material	Cast Iron	Cooling method	IC 411
Frame size	250M	Motor weight - approx.	495 kg
Duty	S1	Gross weight - approx.	530 kg
Voltage variation *	$\pm 10\%$	Motor inertia	0.6214 kgm ²
Frequency variation *	$\pm 5\%$	Load inertia	Customer to Provide
Combined variation *	10%	Vibration level	2.2 mm/s
Design	N	Noise level (1meter distance from motor)	75 dB(A)
Service factor	1.15	No. of starts hot/cold/Equally spread	2/3/4
Insulation class	H	Starting method	DOL
Ambient temperature	-20 to +40 °C	Type of coupling	Direct
Temperature rise (by resistance)	80 [Class B] K	LR withstand time (hot/cold)	15/30 s
Altitude above sea level	1000 meter	Direction of rotation	Bi-directional
Hazardous area classification	NA	Standard rotation	Clockwise form DE
Zone classification	NA	Paint shade	RAL 2008
Gas group	NA	Accessories	
Temperature class	NA	Accessory - 1	PTC 150°C
Rotor type	Aluminum Die cast	Accessory - 2	-
Bearing type	Anti-friction ball	Accessory - 3	-
DE / NDE bearing	6314-C3 / 6314-C3	Terminal box position	RHS
Lubrication method	Regreaseable	Maximum cable size/conduit size	1R x 3C x 95mm ² /2 x M50 x 1.5
Type of grease	CHEVRON SRI-2 or Equivalent	Auxiliary terminal box	YES

 I_A/I_N - Locked Rotor Current / Rated Current T_K/T_N - Breakdown Torque / Rated Torque T_A/T_N - Locked Rotor Torque / Rated Torque**NOTE**

All performance values at rated voltage and frequency.

All performance parameters are subjected to standard tolerance as per IEC 60034-1

* Voltage, Frequency and combine variation are as per IEC60034-1

Technical data are subject to change. There may be slight variations between calculated values in this datasheet and the motor nameplate figures.

Efficiency Standards	Europe IEC:60034-30-1	China -	India -	Aus/Nz AS/NZ 1359:5:2004	Brazil -	Global IEC IEC:60034-30-1

Model No. TCM0551A2113GAC011

Enclosure	U (V)	Δ / Y Conn	f [Hz]	P [kW]	P [hp]	I [A]	n [RPM]	T [kgm]	T [Nm]	IE Class	Amb [°C]	Duty	Elevation [m]	Inertia [kg-m ²]	Weight [kg]
TEFC	400	Δ	50	55	75.0	94.6	2977	18.29	179.37	IE3	40	S1	1000	0.6214	495

Motor Load Data

Load Point		NL	1/4FL	1/2FL	3/4FL	FL	5/4FL
Current	A	30.4	38.3	55.9	75.3	94.6	
Torque	Nm	0.0	44.6	89.3	134.3	179.4	
Speed	r/min	3000	2994	2989	2983	2977	
Efficiency	%	0.0	89.0	93.0	94.3	94.3	
Power Factor	%	7.6	59.3	78.0	86.0	89.0	

Performance vs Load Chart

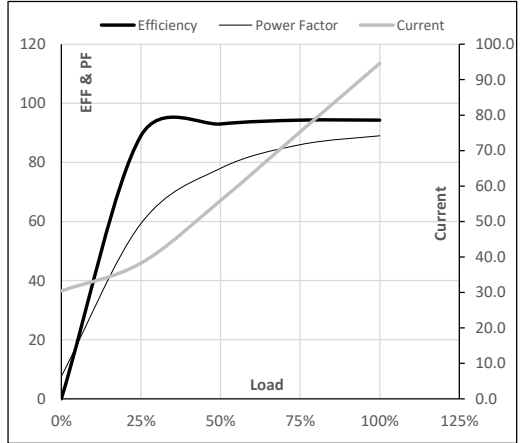

Motor Speed Torque Data

Load Point		LR	P-Up	BD	Rated	NL
Speed	r/min	0	600	2739	2977	3000
Current	A	662.1	595.9	410.3	94.6	30.4
Torque	pu	1.9	1.6	3.4	1	0

Starting Characteristics Chart

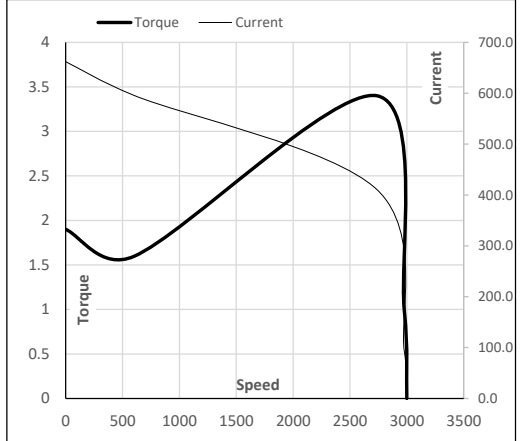

NOTE Refer data sheet for applicable standard and tolerances on performance parameters

Issued By
Issued Date

Model No. TCM0551A2113GAC011

Enclosure	U (V)	Δ / Y Conn	f [Hz]	P [kW]	P [hp]	I [A]	n [rpm]	T [kgm]	T [Nm]	IE Class	Amb [°C]	Duty	Elevation [m]	Inertia [kg-m ²]	Weight [kg]
TEFC	400	Δ	50	55	75	94.6	2977	18.29	179.37	IE3	40	S1	1000	0.6214	495

Motor Speed Torque Data

Load	FL	I ₁	I ₂	I ₃	I ₄	I ₅	LR	
TWT Hot	s 10000	55	35	30	25	19	15	
TWT Cold	s 10000	110	70	60	45	38	30	
Current	pu	1	2	3	4	5	5.5	7

Thermal Characteristics Chart

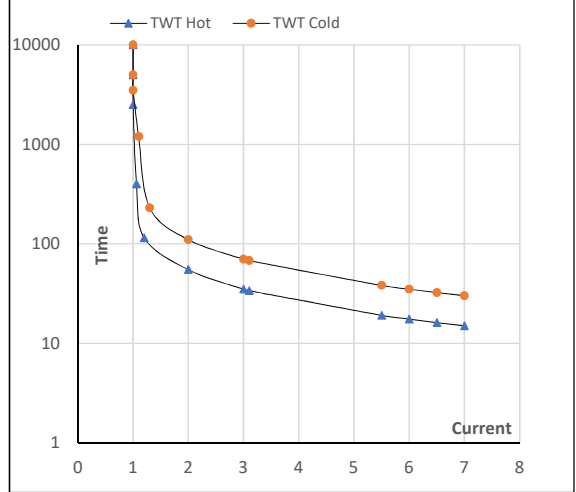

NOTE Refer data sheet for applicable standard and tolerances on performance parameters

Issued By
Issued Date

