

# PRODUCT INFORMATION PACKET

Model No: TCA7P52AF133GAC010

Catalog No: TCA7P52AF133GAC010

TerraMAX® Cast Iron Motor, 10 HP, 3 Ph, 50 Hz, 380 V, 1500 RPM, 132M Frame, TEFC



Regal and Marathon are trademarks of Regal Rexnord Corporation or one of its affiliated companies.

©2022 Regal Rexnord Corporation, All Rights Reserved. MC017097E

### Nameplate Specifications

Output HP	<b>10 Hp</b>	Output KW	<b>7.5 kW</b>
Frequency	<b>50 Hz</b>	Voltage	<b>380 V</b>
Current	<b>15.2 A</b>	Speed	<b>1470 rpm</b>
Service Factor	<b>1</b>	Phase	<b>3</b>
Efficiency	<b>90.4 %</b>	Power Factor	<b>0.83</b>
Duty	<b>S1</b>	Insulation Class	<b>F</b>
Frame	<b>132M</b>	Enclosure	<b>Totally Enclosed Fan Cooled</b>
Thermal Protection	<b>No Protection</b>	Ambient Temperature	<b>40 °C</b>
Drive End Bearing Size	<b>6308</b>	Opp Drive End Bearing Size	<b>6208</b>
UL	<b>No</b>	CSA	<b>No</b>
CE	<b>Yes</b>	IP Code	<b>55</b>
Number of Speeds	<b>1</b>	Efficiency Class	<b>IE3</b>

### Technical Specifications

Electrical Type	<b>Squirrel Cage</b>	Starting Method	<b>Direct On Line</b>
Poles	<b>4</b>	Rotation	<b>Bi-Directional</b>
Mounting	<b>B35</b>	Motor Orientation	<b>Horizontal</b>
Drive End Bearing	<b>2Z-C3</b>	Opp Drive End Bearing	<b>2Z-C3</b>
Frame Material	<b>Cast Iron</b>	Shaft Type	<b>Keyed</b>
Overall Length	<b>503 mm</b>	Frame Length	<b>240 mm</b>
Shaft Diameter	<b>38 mm</b>	Shaft Extension	<b>80 mm</b>
Assembly/Box Mounting	<b>R Side</b>		
Connection Drawing	<b>8442000085</b>	Outline Drawing	<b>0213200967</b>

This is an uncontrolled document once printed or downloaded and is subject to change without notice. Date Created:12/01/2022

# OUTLINE

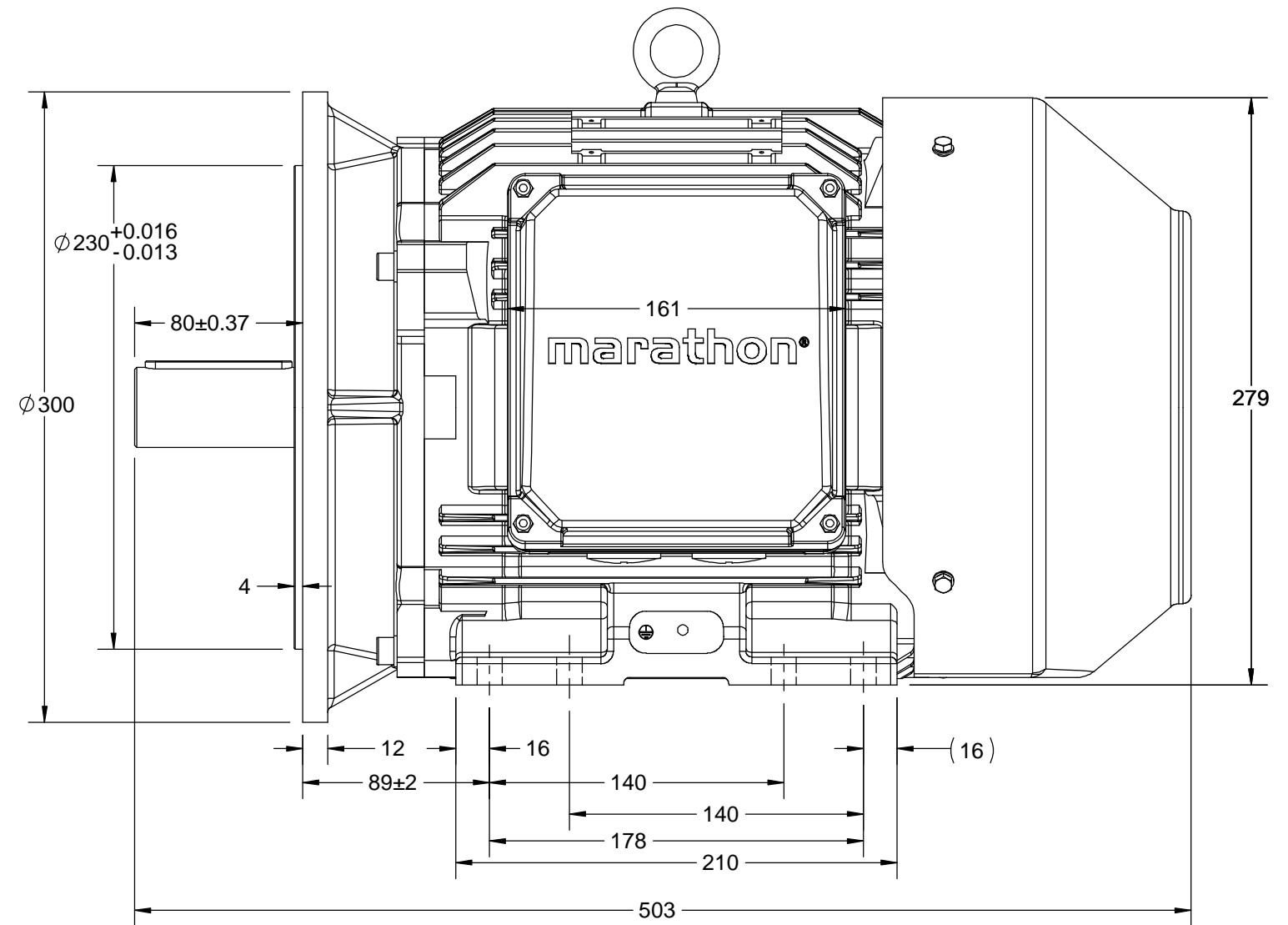
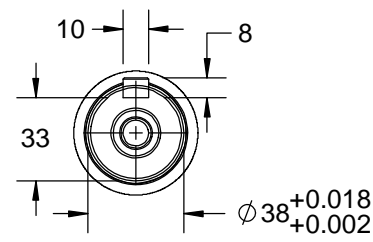
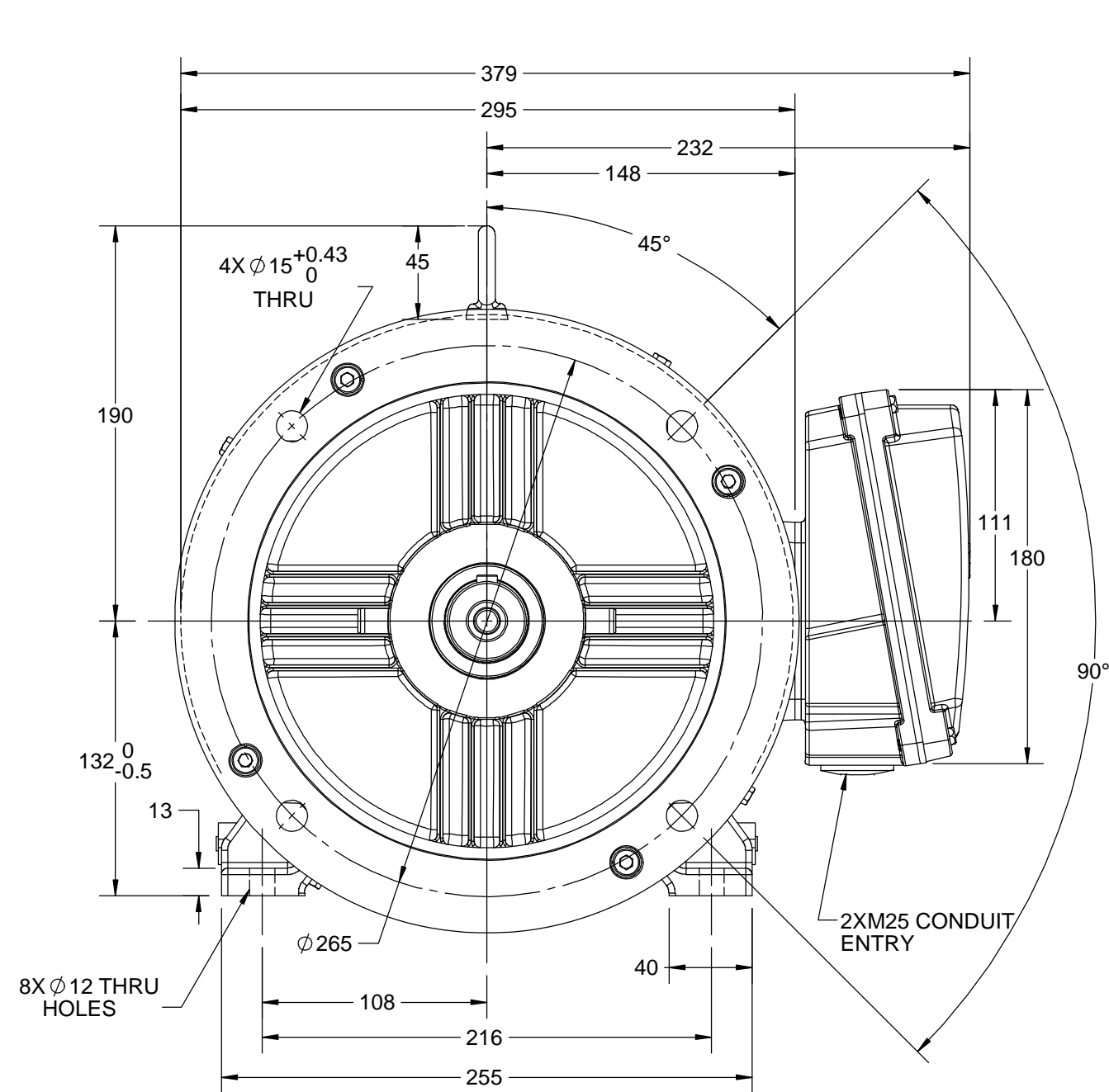

DRAWING REVISION B	REVISION BY BISWA	DATE 16/07/2018
ECO ECO-0148344	APPROVED BY SBD	DATE 16/07/2018
ECO DESCRIPTION		
DRAWING UPDATED		
<small>COPYRIGHT REGAL BELOIT AMERICA, INC. ALL RIGHTS RESERVED. PROPRIETARY AND CONFIDENTIAL INFORMATION - THIS DOCUMENT IS THE PROPERTY OF REGAL BELOIT AMERICA, INC. ("OWNER") AND CONTAINS OWNER'S PROPRIETARY INFORMATION. ANY PERSON, CORPORATION OR OTHER FIRM RECEIVING IT IS DEEMED, BY RECEIVING IT, TO AGREE THAT IT, AND/OR ANY PART OF IT, SHALL NOT BE DISCLOSED TO ANY PERSON, CORPORATION OR OTHER ENTITY, DUPLICATED, AND/OR USED, EXCEPT AS EXPRESSLY APPROVED IN WRITING IN ADVANCE BY OWNER. THIS DOCUMENT SHALL BE RETURNED TO OWNER UPON REQUEST. IT MAY BE SUBJECT TO CERTAIN RESTRICTIONS UNDER APPLICABLE EXPORT CONTROL LAWS AND REGULATIONS.</small>		

DRAWN BY SN	<b>marathon™</b> Motors	
DATE 11/08/2016		
APPROVED BY SBD	DESCRIPTION <b>OUTLINE</b>	
DATE 11/08/2016	132M FR- B35 MTG.TYPE: TCA/QCA- RHS TB	
REFERENCE	MATERIAL	PROCESS/FINISH
THIRD ANGLE PROJECTION	SIZE B	DRAWING NUMBER 0213200967
		SHEET 1 OF 1

COPYRIGHT REGAL BELOIT AMERICA, INC. ALL RIGHTS RESERVED. UNAUTHORIZED REPRODUCTION OR DISTRIBUTION OF THIS DOCUMENT IS PROHIBITED. REGAL BELOIT AMERICA, INC. ("OWNER") AND CONTAINS OWNER'S PROPRIETARY INFORMATION. ANY PERSON, CORPORATION OR OTHER FIRM RECEIVING IT IS DEEMED, BY RECEIVING IT, TO AGREE THAT IT, AND/OR ANY PART OF IT, SHALL NOT BE DISCLOSED TO ANY PERSON, CORPORATION OR OTHER ENTITY, DUPLICATED, AND/OR USED, EXCEPT AS EXPRESSLY APPROVED IN WRITING IN ADVANCE BY OWNER. THIS DOCUMENT SHALL BE RETURNED TO OWNER UPON REQUEST. IT MAY BE SUBJECT TO CERTAIN RESTRICTIONS UNDER APPLICABLE EXPORT CONTROL LAWS AND REGULATIONS.

DRAWING REVISION <b>A</b>	REVISION BY <b>SN</b>	DATE <b>13/01/2017</b>
ECO <b>ECO-0116390</b>	APPROVED BY <b>SBD</b>	DATE <b>13/01/2017</b>
ECO DESCRIPTION <b>NEW DRAWING RELEASE</b>		

GEOMETRIC TOLERANCE		
LINEAR DIM	>0~6	±0.1
	>6~30	±0.2
	>30~120	±0.3



**NOTES:**

1. PRESSURE-SENSITIVE ADHESIVE COATED PAPER ON THE BACK OF SELF-ADHESIVE.
2. AT THE END OF YELLOW, WORDS, SYMBOLS, LETTERS ARE BLACK, BORDER IS BLACK.
3. THE TOLERANCE OF THE LINEAR SIZE OF THE TOLERANCE WITHOUT THE TOLERANCE BY THE TABLE.

8WD.442.2017

	DRAWN BY <b>SN</b>		<b>Regal Beloit America, Inc.</b>	
	DATE <b>16/12/2016</b>			
	APPROVED BY <b>SBD</b>		DESCRIPTION <b>CONN DIAGRAM-NAMEPLATE</b>	
	DATE <b>16/12/2016</b>			
	REFERENCE		MATERIAL	PROCESS/FINISH
	THIRD ANGLE PROJECTION		SIZE <b>A</b>	DRAWING NUMBER <b>8442000085</b>

Model No. TCA7P52AF133GAC010

U (V)	Δ / Y Conn	f [Hz]	P [kW]	P [hp]	I [A]	n [RPM]	T [Nm]	IE Class	% EFF at __ load			PF at __ load			I <sub>A</sub> /I <sub>N</sub> [pu]	T <sub>A</sub> /T <sub>N</sub> [pu]	T <sub>K</sub> /T <sub>N</sub> [pu]	
									5/4FL	FL	3/4FL	1/2FL	FL	3/4FL				1/2FL
380	Δ	50	7.5	10	15.19	1470	48.47	IE3	-	90.4	90.4	90.4	0.83	0.77	0.65	7.5	2.8	3

Motor type	TCA	Degree of protection	IP 55
Enclosure	TEFC	Mounting type	IM B35
Frame Material	Cast Iron	Cooling method	IC 411
Frame size	132M	Motor weight - approx.	97 kg
Duty	S1	Gross weight - approx.	100 kg
Voltage variation *	± 10%	Motor inertia	0.0550 kgm <sup>2</sup>
Frequency variation *	± 5%	Load inertia	Customer to Provide
Combined variation *	10%	Vibration level	1.6 mm/s
Design	N	Noise level ( 1meter distance from motor)	61 dB(A)
Service factor	1.0	No. of starts hot/cold/Equally spread	2/3/4
Insulation class	F	Starting method	DOL
Ambient temperature	-20 to +40 °C	Type of coupling	Direct
Temperature rise (by resistance)	80 [ Class B ] K	LR withstand time (hot/cold)	10/20 s
Altitude above sea level	1000 meter	Direction of rotation	Bi-directional
Hazardous area classification	NA	Standard rotation	Clockwise form DE
Zone classification	NA	Paint shade	RAL 5014
Gas group	NA	Accessories	
Temperature class	NA	Accessory - 1	PTC 150°C
Rotor type	Aluminum Die cast	Accessory - 2	-
Bearing type	Anti-friction ball	Accessory - 3	-
DE / NDE bearing	6308-2Z / 6208-2Z	Terminal box position	RHS
Lubrication method	Greased for life	Maximum cable size/conduit size	1R x 3C x 16mm <sup>2</sup> /2 x M25 x 1.5
Type of grease	NA	Auxiliary terminal box	NA

I<sub>A</sub>/I<sub>N</sub> - Locked Rotor Current / Rated Current

T<sub>K</sub>/T<sub>N</sub> - Breakdown Torque / Rated Torque

T<sub>A</sub>/T<sub>N</sub> - Locked Rotor Torque / Rated Torque

**NOTE**

All performance values at rated voltage and frequency.

All performance parameters are subjected to standard tolerance as per IEC 60034-1

\* Voltage, Frequency and combine variation are as per IEC60034-1

Technical data are subject to change. There may be discrepancies between calculated and name plate values.

Efficiency Standards	Europe	China	India	Aus/Nz	Brazil	Global IEC
	-	GB 18613-2012 Grade 2	-	-	-	IEC: 60034-30





Model No. TCA7P52AF133GAC010

Enclosure	U (V)	Δ / Y Conn	f [Hz]	P [kW]	P [hp]	I [A]	n [RPM]	T [kgm]	T [Nm]	IE Class	Amb [°C]	Duty	Elevation [m]	Inertia [kg-m <sup>2</sup> ]	Weight [kg]
TEFC	380	Δ	50	7.5	10	15.2	1470	4.94	48.47	IE3	40	S1	1000	0.055	97

**Motor Load Data**

Load Point		NL	1/4FL	1/2FL	3/4FL	FL	5/4FL
Current	A	6.3	6.9	9.1	11.5	15.2	
Torque	Nm	0.0	11.9	24.0	36.1	48.5	
Speed	r/min	1500	1493	1486	1478	1470	
Efficiency	%	0.0	86.1	90.4	90.4	90.4	
Power Factor	%	6.3	45.2	65.0	77.0	83.0	

**Performance vs Load Chart**

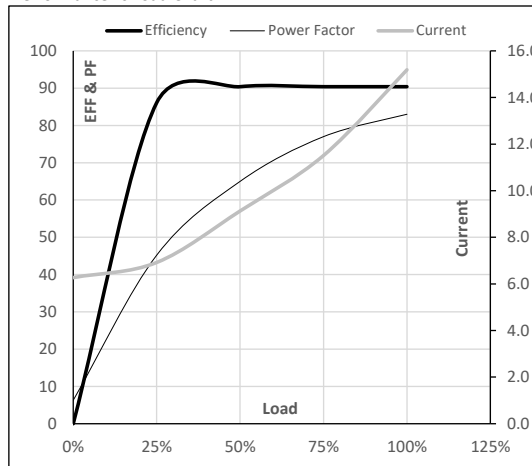

**Motor Speed Torque Data**

Load Point		LR	P-Up	BD	Rated	NL
Speed	r/min	0	300	1275	1470	1500
Current	A	113.9	102.5	58.7	15.2	6.3
Torque	pu	2.8	2.3	3.0	1	0

**Starting Characteristics Chart**

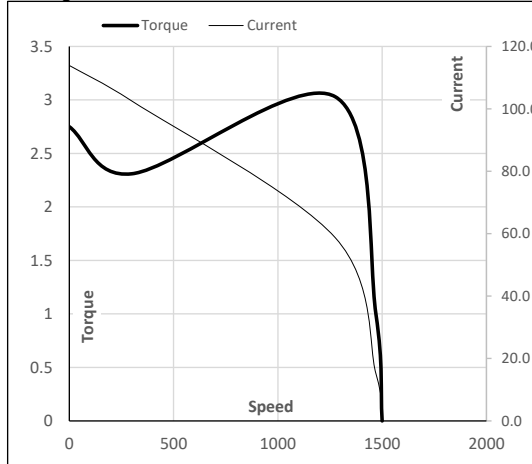

**NOTE** Refer data sheet for applicable standard and tolerances on performance parameters

Issued By  
Issued Date





Model No. TCA7P52AF133GAC010

Enclosure	U (V)	$\Delta / Y$ Conn	f [Hz]	P [kW]	P [hp]	I [A]	n [rpm]	T [kgm]	T [Nm]	IE Class	Amb [°C]	Duty	Elevation [m]	Inertia [kg-m <sup>2</sup> ]	Weight [kg]
TEFC	380	$\Delta$	50	7.5	10.0	15.2	1470	4.94	48.47	IE3	40	S1	1000	0.055	97

**Motor Speed Torque Data**

Load	FL	$I_1$	$I_2$	$I_3$	$I_4$	$I_5$	LR	
TWT Hot	s 10000	38	26	19	16	13	10	
TWT Cold	s 10000	75	50	38	35	24	20	
Current	pu	1	2	3	4	5	5.5	7.5

**Thermal Characteristics Chart**

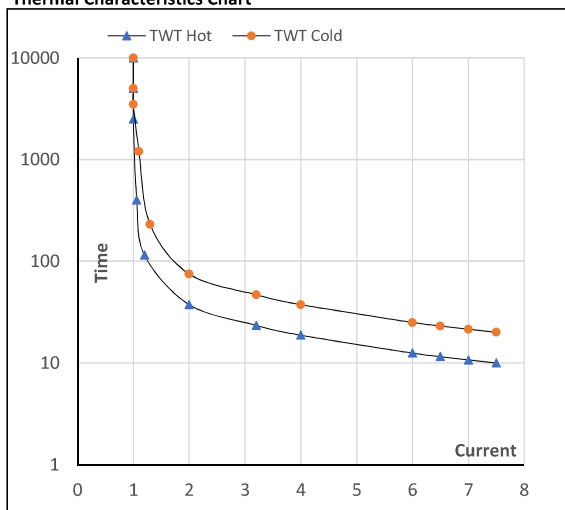

**NOTE** Refer data sheet for applicable standard and tolerances on performance parameters

Issued By  
Issued Date

