

PRODUCT INFORMATION PACKET

Model No: TCA2204A1113GAC010

Catalog No: TCA2204A1113GAC010

TerraMAX® Cast Iron Motor, 295 HP, 3 Ph, 50 Hz, 400 V, 750 RPM, 355L Frame, TEFC

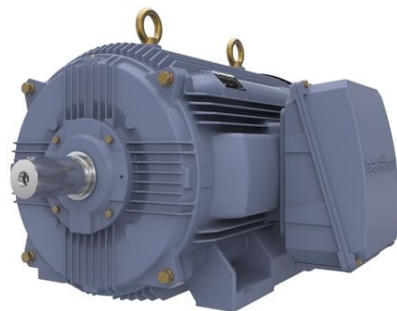

Regal and Marathon are trademarks of Regal Rexnord Corporation or one of its affiliated companies.
©2022 Regal Rexnord Corporation, All Rights Reserved. MC017097E

Nameplate Specifications

Output HP	295 Hp	Output KW	220.0 kW
Frequency	50 Hz	Voltage	400 V
Current	399.6 A	Speed	742 rpm
Service Factor	1	Phase	3
Efficiency	94.6 %	Power Factor	0.84
Duty	S1	Insulation Class	F
Frame	355L	Enclosure	Totally Enclosed Fan Cooled
Thermal Protection	No Protection	Ambient Temperature	40 °C
Drive End Bearing Size	6322	Opp Drive End Bearing Size	6322
UL	No	CSA	No
CE	Yes	IP Code	55
Efficiency Class	IE3		

Technical Specifications

Electrical Type	Squirrel Cage	Starting Method	Direct On Line
Poles	8	Rotation	Bi-Directional
Mounting	B3	Motor Orientation	Horizontal
Drive End Bearing	C3	Opp Drive End Bearing	C3
Frame Material	Cast Iron	Shaft Type	Keyed
Overall Length	1542 mm	Frame Length	1010 mm
Shaft Diameter	95 mm	Shaft Extension	170 mm
Assembly/Box Mounting	R Side		
Connection Drawing	8442000085	Outline Drawing	0235502296

This is an uncontrolled document once printed or downloaded and is subject to change without notice. Date Created:12/01/2022

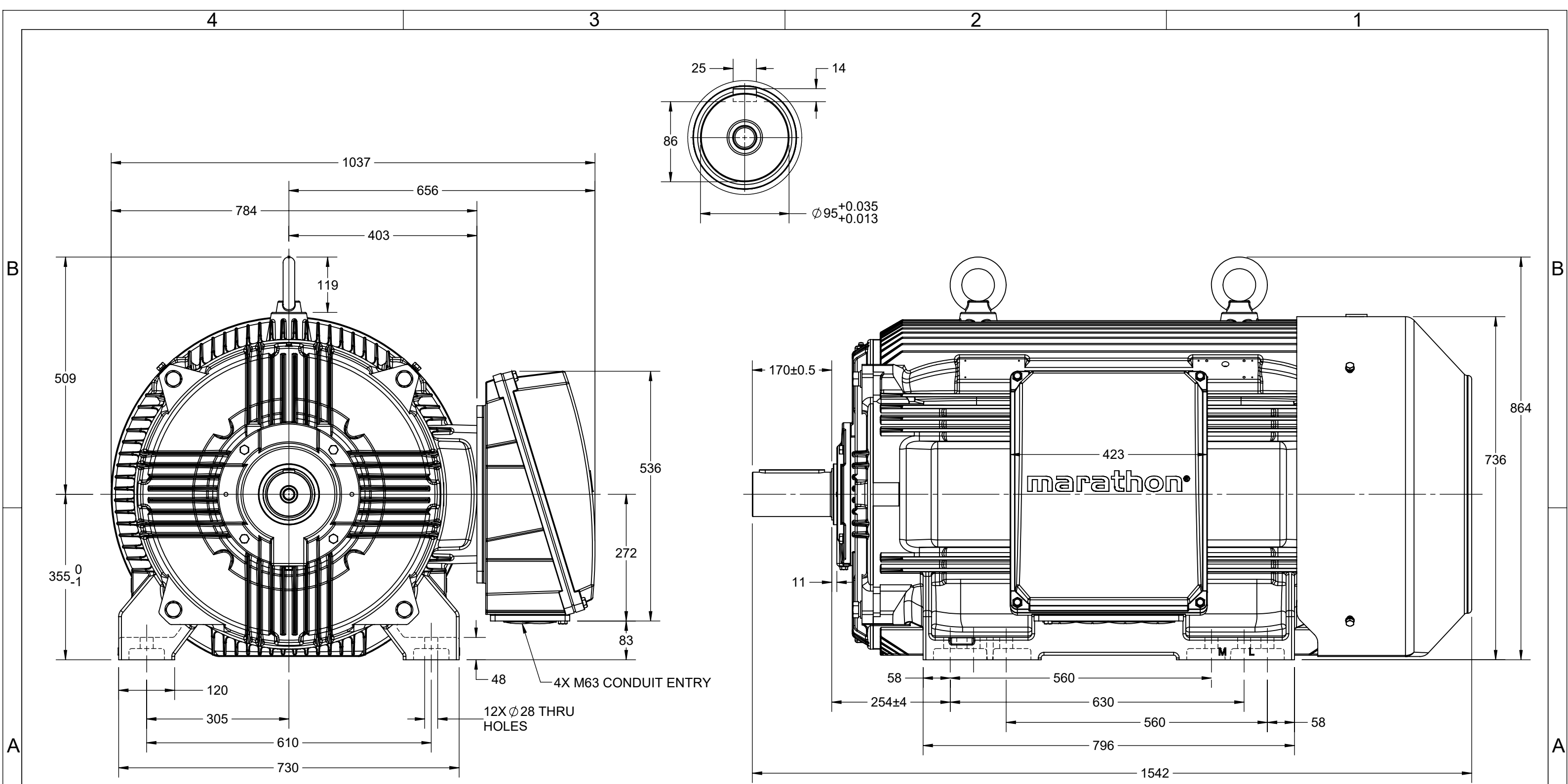

DRAWING REVISION C	REVISION BY LK	DATE 07/09/2020
ECO CR-0000087	APPROVED BY JAY	DATE 07/09/2020
ECO DESCRIPTION MODEL UPDATED		
<small>COPYRIGHT REGAL BELOIT AMERICA, INC. ALL RIGHTS RESERVED. PROPRIETARY AND CONFIDENTIAL INFORMATION - THIS DOCUMENT IS THE PROPERTY OF REGAL BELOIT AMERICA, INC. ("OWNER") AND CONTAINS OWNER'S PROPRIETARY INFORMATION. ANY PERSON, CORPORATION OR OTHER FIRM RECEIVING IT IS DEEMED, BY RECEIVING IT, TO AGREE THAT IT, AND/OR ANY PART OF IT, SHALL NOT BE DISCLOSED TO ANY PERSON, CORPORATION OR OTHER ENTITY, DUPLICATED, AND/OR USED, EXCEPT AS EXPRESSLY APPROVED IN WRITING IN ADVANCE BY OWNER. THIS DOCUMENT SHALL BE RETURNED TO OWNER UPON REQUEST. IT MAY BE SUBJECT TO CERTAIN RESTRICTIONS UNDER APPLICABLE EXPORT CONTROL LAWS AND REGULATIONS.</small>		

DRAWN BY SKM	marathon™ Motors	
DATE 11/08/2017		
APPROVED BY JAY	DESCRIPTION OUTLINE 355L-4~8P-B3	
DATE 11/08/2017	MATERIAL	PROCESS/FINISH
REFERENCE	SIZE B	DRAWING NUMBER 0235502296
THIRD ANGLE PROJECTION	SHEET 1 OF 1	



Model No. TCA2204A1113GAC010

U (V)	Δ / Y Conn	f [Hz]	P		I [A]	n [RPM]	T [Nm]	IE Class	% EFF at __ load				PF at __ load			I _A /I _N [pu]	T _A /T _N [pu]	T _K /T _N [pu]
			[kW]	[hp]					5/4FL	FL	3/4FL	1/2FL	FL	3/4FL	1/2FL			
400	Δ	50	220	295	399.6	742	2879.3	IE3	-	94.6	94.6	95.2	0.84	0.81	0.73	6.1	1.6	2.4

Motor type	TCA	Degree of protection	IP 55
Enclosure	TEFC	Mounting type	IM B3
Frame Material	Cast Iron	Cooling method	IC 411
Frame size	355L	Motor weight - approx.	2149 kg
Duty	S1	Gross weight - approx.	2194 kg
Voltage variation *	± 10%	Motor inertia	14.7210 kgm ²
Frequency variation *	± 5%	Load inertia	Customer to Provide
Combined variation *	10%	Vibration level	2.8 mm/s
Design	N	Noise level (1meter distance from motor)	65 dB(A)
Service factor	1.0	No. of starts hot/cold/Equally spread	2/3/4
Insulation class	F	Starting method	DOL
Ambient temperature	-20 to +40 °C	Type of coupling	Direct
Temperature rise (by resistance)	80 [Class B] K	LR withstand time (hot/cold)	15/30 s
Altitude above sea level	1000 meter	Direction of rotation	Bi-directional
Hazardous area classification	NA	Standard rotation	Clockwise form DE
Zone classification	NA	Paint shade	RAL 5014
Gas group	NA	Accessories	
Temperature class	NA	Accessory - 1	PTC 150°C
Rotor type	Aluminum Die cast	Accessory - 2	-
Bearing type	Anti-friction ball	Accessory - 3	-
DE / NDE bearing	6322 C3 / 6322 C3	Terminal box position	RHS
Lubrication method	Regreasable	Maximum cable size/conduit size	1R x 3C x 300mm ² /4 x M63 x 1.5
Type of grease	CHEVRON SRI-2 or Equivalent	Auxiliary terminal box	NA

I_A/I_N - Locked Rotor Current / Rated Current
 T_A/T_N - Locked Rotor Torque / Rated Torque

T_K/T_N - Breakdown Torque / Rated Torque

NOTE

All performance values at rated voltage and frequency.

All performance parameters are subjected to standard tolerance as per IEC 60034-1

* Voltage, Frequency and combine variation are as per IEC60034-1

Technical data are subject to change. There may be discrepancies between calculated and name plate values.

Efficiency Standards	Europe	China	India	Aus/Nz	Brazil	Global IEC
	-	GB 18613-2012 Grade 2	-	-	-	IEC: 60034-30

