

PRODUCT INFORMATION PACKET



Model No: SD103

Catalog No: SD103

Severe Duty Motor, 1.5 HP, 3 Ph, 60 Hz, 208-230/460 V, 1800 RPM, 145T Frame, TEFC



Regal and Century are trademarks of Regal Rexnord Corporation or one of its affiliated companies.

©2022 Regal Rexnord Corporation, All Rights Reserved. MC017097E





Nameplate Specifications

Output HP	1.5 Hp	Output KW	1.1 kW
Frequency	60 Hz	Voltage	208-230/460 V
Current	1.95 A	Speed	1740 rpm
Service Factor	1.15	Phase	3
Duty	Continuous	Insulation Class	F
Frame	145T	Enclosure	Totally Enclosed Fan Cooled
Thermal Protection	No Protection	Ambient Temperature	40 °C
UL	Recognized	CSA	Y
CE	Y	Number of Speeds	1

Technical Specifications

Electrical Type	POLYPHASE	Starting Method	Across The Line
Poles	4	Rotation	Reversible
Mounting	Rigid Base	Drive End Bearing	Ball
Opp Drive End Bearing	Ball	Frame Material	Cast Iron
Shaft Type	Keyed	Overall Length	14.20 in
Frame Length	6.75 in	Shaft Diameter	0.875 in
Shaft Extension	2.25 in		
Outline Drawing	SS620599	Connection Drawing	A-EE7308

This is an uncontrolled document once printed or downloaded and is subject to change without notice. Date Created:11/29/2022

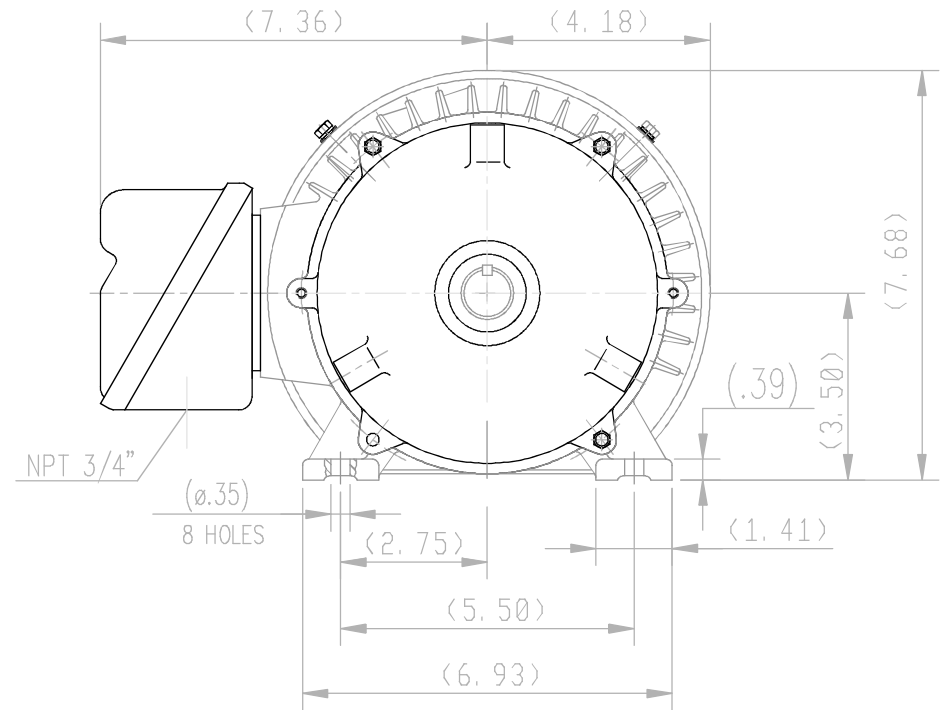
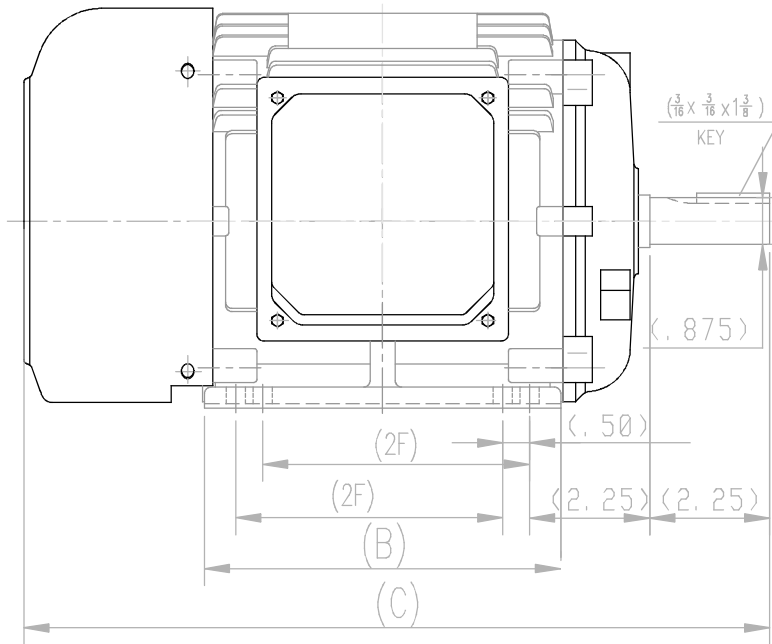

143T	13.2	5.71	4.0
145T	14.2	6.70	5.0
FRAME	C	B	2F

				TOLERANCES UNLESS SPECIFIED		Regal-Beloit Corporation		DRAWN ZYH 7.5.2012	
				DEC.	INCHES			CHK HZJ 7.5.2012	
				.X	±.1	TITLE		SCALE	
				.XX	±.03	143/145T FR TEFC-SEVERE DUTY		APPD WGH 7.5.2012	
				.XXX	±.005	MAT'L		REF	
				.XXXX	±.0005	FINISH		FMF	
NO.	REVISION	BY & DATE	CHK	ANG	±1/2	CAD FILE		SIZE	DRAWING NO.
THIS DRAWING IN DESIGN AND DETAIL IS OUR PROPERTY AND MUST NOT BE USED EXCEPT IN CONNECTION WITH OUR WORK ALL RIGHTS OF DESIGN AND INVENTION ARE RESERVED THIS IS AN ELECTRONICALLY GENERATED DOCUMENT - DO NOT SCALE THIS PRINT						RFP	SS620599	B	SS620599
						DIST			REV.

EE7308

THREE PHASE
DUAL VOLTAGE MOTOR



VIEW OF TERMINAL END

REF.
WINDING DIAGRAM

T8Y, T2Y, T2BL, T4BX, T2EC, T2G
T6BZ, T2B, T6BL, T4AV, T6B, T4B

OPTIONAL CORD
CONNECTION

L1 — WHITE
L2 — RED
L3 — BLACK

NO.	REVISION	BY & DATE	CHK	ANG	TOLERANCES UNLESS SPECIFIED		FINISH	DRAWN RM 11/20/1990				
					DEC.	INCHES						
5	CHG TO REGAL LOGO	SL 09/10/2015	AB					CHK ML 11/21/1990				
4	REVISED IEC NOTATIONS	MSG 11/15/2011	CMN	.X	±.1			APPD SAS 04/24/2003				
3	ADDED IEC NOTATIONS... (U1), (V1) ETC. MU95194	MSG 5/10/2010	MJS	.XX	±.02			SCALE 1=1				
2	ADDED THE OPTIONAL CORD CONNECTION MU46318	RDH 04/24/2003	DRS	.XXX	±.005		TITLE CONNECTION DIAGRAM 3Ø - DUAL VOLTAGE MOTOR	REF				
1	REDRAWN	RM 11/20/1990		.XXXX	±.0005		MAT'L.	FMF				
					±7'30"			PREV				
THIS DRAWING IN DESIGN AND DETAIL IS OUR PROPERTY AND MUST NOT BE USED EXCEPT IN CONNECTION WITH OUR WORK ALL RIGHTS OF DESIGN AND INVENTION ARE RESERVED THIS IS AN ELECTRONICALLY GENERATED DOCUMENT - DO NOT SCALE THIS PRINT							RFP	CAD FILE ee7308	SIZE A	DRAWING NO. EE7308	PAGE OF 5	REV. 5
							DIST WP					

