

PRODUCT INFORMATION PACKET

Model No: SCA5P54A1131GAA001

Catalog No: SCA5P54A1131GAA001

TerraMAX® Cast Iron Motor, 7.50 HP, 3 Ph, 50 Hz, 400 V, 750 RPM, 160M Frame, TEFC



Regal and Marathon are trademarks of Regal Rexnord Corporation or one of its affiliated companies.
©2022 Regal Rexnord Corporation, All Rights Reserved. MC017097E



Nameplate Specifications

Output HP	7.50 Hp	Output KW	5.5 kW
Frequency	50 Hz	Voltage	400 V
Current	13.2 A	Speed	720 rpm
Service Factor	1	Phase	3
Efficiency	83.8 %	Power Factor	0.72
Duty	S1	Insulation Class	F
Frame	160M	Enclosure	Totally Enclosed Fan Cooled
Thermal Protection	No Protection	Ambient Temperature	40 °C
Drive End Bearing Size	6309	Opp Drive End Bearing Size	6209
UL	No	CSA	No
CE	Yes	IP Code	55
Number of Speeds	1	Efficiency Class	IE2

Technical Specifications

Electrical Type	Squirrel Cage	Starting Method	Direct On Line
Poles	8	Rotation	Bi-Directional
Mounting	B35	Motor Orientation	Horizontal
Drive End Bearing	2z-C3	Opp Drive End Bearing	2z-C3
Frame Material	Cast Iron	Shaft Type	Keyed
Overall Length	622 mm	Frame Length	254 mm
Shaft Diameter	42 mm	Shaft Extension	110 mm
Assembly/Box Mounting	Top		
Outline Drawing	0216000950	Connection Drawing	8442000085

This is an uncontrolled document once printed or downloaded and is subject to change without notice. Date Created:12/01/2022

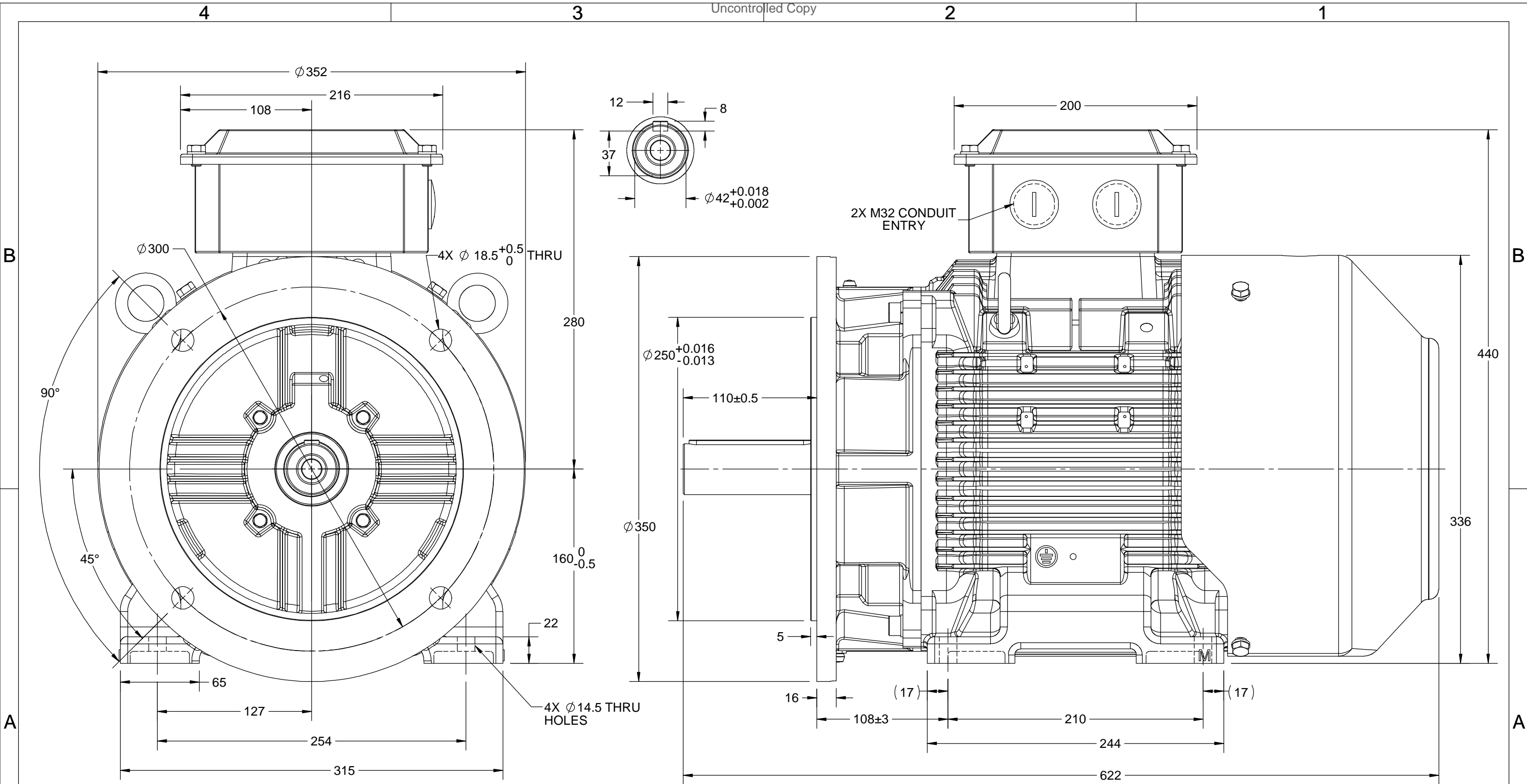

DRAWING REVISION B	REVISION BY VS	DATE 13/08/2018
ECO ECO-0150628	APPROVED BY JAY	DATE 13/08/2018
ECO DESCRIPTION MODEL UPDATED		
<small>COPYRIGHT REGAL BELOIT AMERICA, INC. ALL RIGHTS RESERVED. PROPRIETARY AND CONFIDENTIAL INFORMATION - THIS DOCUMENT IS THE PROPERTY OF REGAL BELOIT AMERICA, INC. ("OWNER") AND CONTAINS OWNER'S PROPRIETARY INFORMATION. ANY PERSON, CORPORATION OR OTHER FIRM RECEIVING IT IS DEEMED, BY RECEIVING IT, TO AGREE THAT IT, AND/OR ANY PART OF IT, SHALL NOT BE DISCLOSED TO ANY PERSON, CORPORATION OR OTHER ENTITY, DUPLICATED, AND/OR USED, EXCEPT AS EXPRESSLY APPROVED IN WRITING IN ADVANCE BY OWNER. THIS DOCUMENT SHALL BE RETURNED TO OWNER UPON REQUEST. IT MAY BE SUBJECT TO CERTAIN RESTRICTIONS UNDER APPLICABLE EXPORT CONTROL LAWS AND REGULATIONS.</small>		

DRAWN BY GSR
DATE 29/03/2018
APPROVED BY JAY
DATE 29/03/2018
REFERENCE
THIRD ANGLE PROJECTION

marathon™ Motors		
OUTLINE		
160M FR B35-MTG MOTOR TYPE:SCA		
MATERIAL	PROCESS/FINISH	
SIZE B	DRAWING NUMBER 0216000950	SHEET 1 OF 1

COPYRIGHT REGAL BELOIT AMERICA, INC. ALL RIGHTS RESERVED. UNAUTHORIZED REPRODUCTION OR DISTRIBUTION OF THIS DOCUMENT IS PROHIBITED. REGAL BELOIT AMERICA, INC. ("OWNER") AND CONTAINS OWNER'S PROPRIETARY INFORMATION. ANY PERSON, CORPORATION OR OTHER FIRM RECEIVING IT IS DEEMED, BY RECEIVING IT, TO AGREE THAT IT, AND/OR ANY PART OF IT, SHALL NOT BE DISCLOSED TO ANY PERSON, CORPORATION OR OTHER ENTITY, DUPLICATED, AND/OR USED, EXCEPT AS EXPRESSLY APPROVED IN WRITING IN ADVANCE BY OWNER. THIS DOCUMENT SHALL BE RETURNED TO OWNER UPON REQUEST. IT MAY BE SUBJECT TO CERTAIN RESTRICTIONS UNDER APPLICABLE EXPORT CONTROL LAWS AND REGULATIONS.

DRAWING REVISION A	REVISION BY SN	DATE 13/01/2017
ECO ECO-0116390	APPROVED BY SBD	DATE 13/01/2017
ECO DESCRIPTION NEW DRAWING RELEASE		

GEOMETRIC TOLERANCE		
LINEAR DIM	>0~6	±0.1
	>6~30	±0.2
	>30~120	±0.3



NOTES:

1. PRESSURE-SENSITIVE ADHESIVE COATED PAPER ON THE BACK OF SELF-ADHESIVE.
2. AT THE END OF YELLOW, WORDS, SYMBOLS, LETTERS ARE BLACK, BORDER IS BLACK.
3. THE TOLERANCE OF THE LINEAR SIZE OF THE TOLERANCE WITHOUT THE TOLERANCE BY THE TABLE.

8WD.442.2017



DRAWN BY SN	DATE 16/12/2016			 Regal Beloit America, Inc.
	APPROVED BY SBD	DESCRIPTION CONN DIAGRAM-NAMEPLATE		
	DATE 16/12/2016	REFERENCE	MATERIAL	PROCESS/FINISH
	THIRD ANGLE PROJECTION 	SIZE A	DRAWING NUMBER 8442000085	SHEET 1 OF 1