

# PRODUCT INFORMATION PACKET

Model No: SCA1504A4133GAA001

Catalog No: SCA1504A4133GAA001

TerraMAX® Cast Iron Motor, 200 HP, 3 Ph, 50 Hz, 380/660 V, 750 RPM, 355M Frame, TEFC



Regal and Marathon are trademarks of Regal Rexnord Corporation or one of its affiliated companies.  
©2022 Regal Rexnord Corporation, All Rights Reserved. MC017097E



### Nameplate Specifications

Output HP	<b>200 Hp</b>	Output KW	<b>150.0 kW</b>
Frequency	<b>50 Hz</b>	Voltage	<b>380/660 V</b>
Current	<b>299.2 A</b>	Speed	<b>742 rpm</b>
Service Factor	<b>1</b>	Phase	<b>3</b>
Efficiency	<b>92.9 %</b>	Power Factor	<b>0.82</b>
Duty	<b>S1</b>	Insulation Class	<b>F</b>
Frame	<b>355M</b>	Enclosure	<b>Totally Enclosed Fan Cooled</b>
Thermal Protection	<b>No Protection</b>	Ambient Temperature	<b>40 °C</b>
Drive End Bearing Size	<b>6322</b>	Opp Drive End Bearing Size	<b>6322</b>
UL	<b>No</b>	CSA	<b>No</b>
CE	<b>Yes</b>	IP Code	<b>55</b>
Number of Speeds	<b>1</b>	Efficiency Class	<b>IE2</b>

### Technical Specifications

Electrical Type	<b>Squirrel Cage</b>	Starting Method	<b>Direct On Line</b>
Poles	<b>8</b>	Rotation	<b>Bi-Directional</b>
Mounting	<b>B35</b>	Motor Orientation	<b>Horizontal</b>
Drive End Bearing	<b>C3</b>	Opp Drive End Bearing	<b>C3</b>
Frame Material	<b>Cast Iron</b>	Shaft Type	<b>Keyed</b>
Overall Length	<b>1542 mm</b>	Frame Length	<b>1010 mm</b>
Shaft Diameter	<b>95 mm</b>	Shaft Extension	<b>170 mm</b>
Assembly/Box Mounting	<b>R Side</b>		
Connection Drawing	<b>8442000085</b>	Outline Drawing	<b>0235502333</b>

This is an uncontrolled document once printed or downloaded and is subject to change without notice. Date Created:12/01/2022

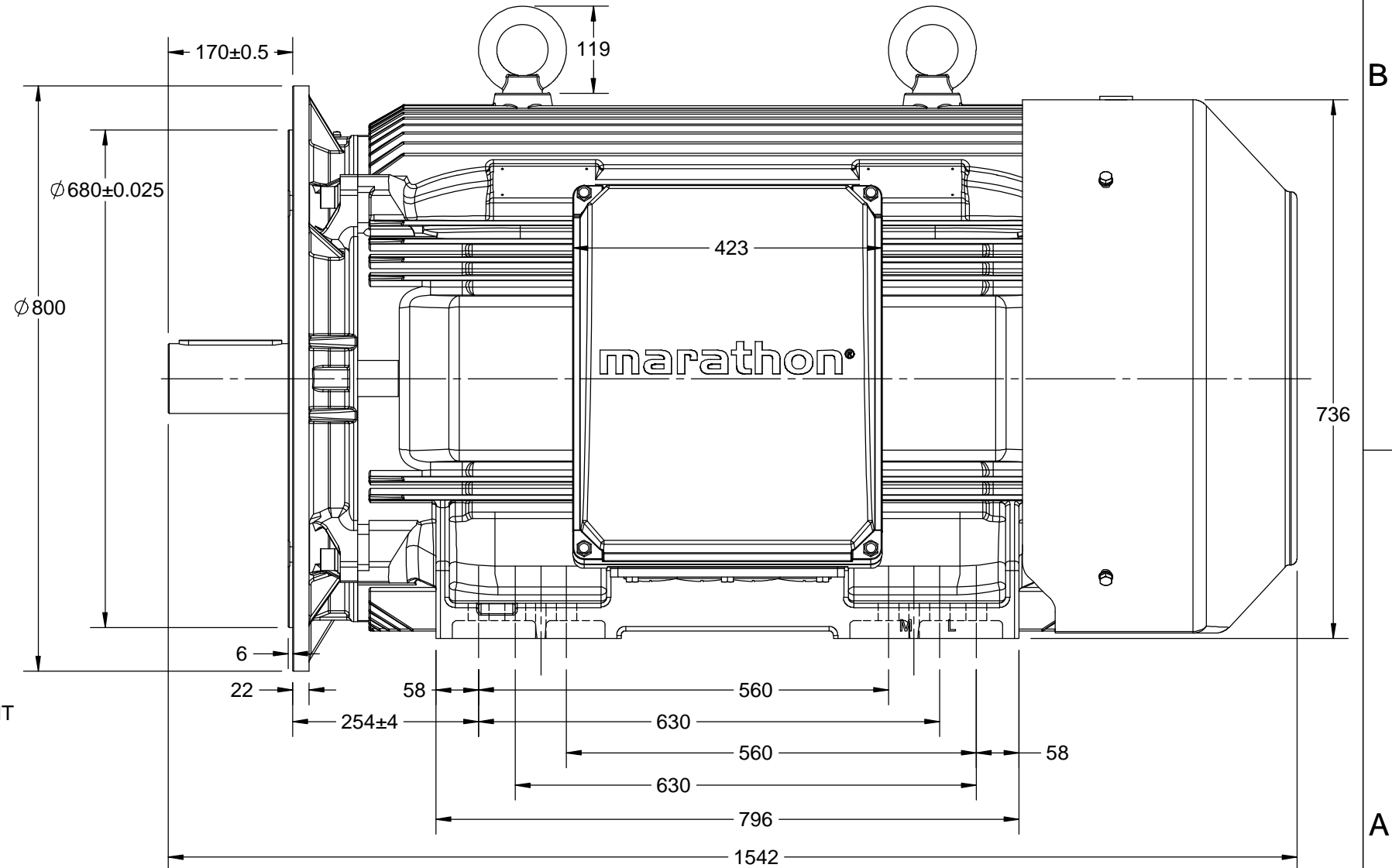
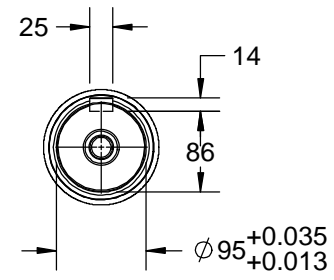
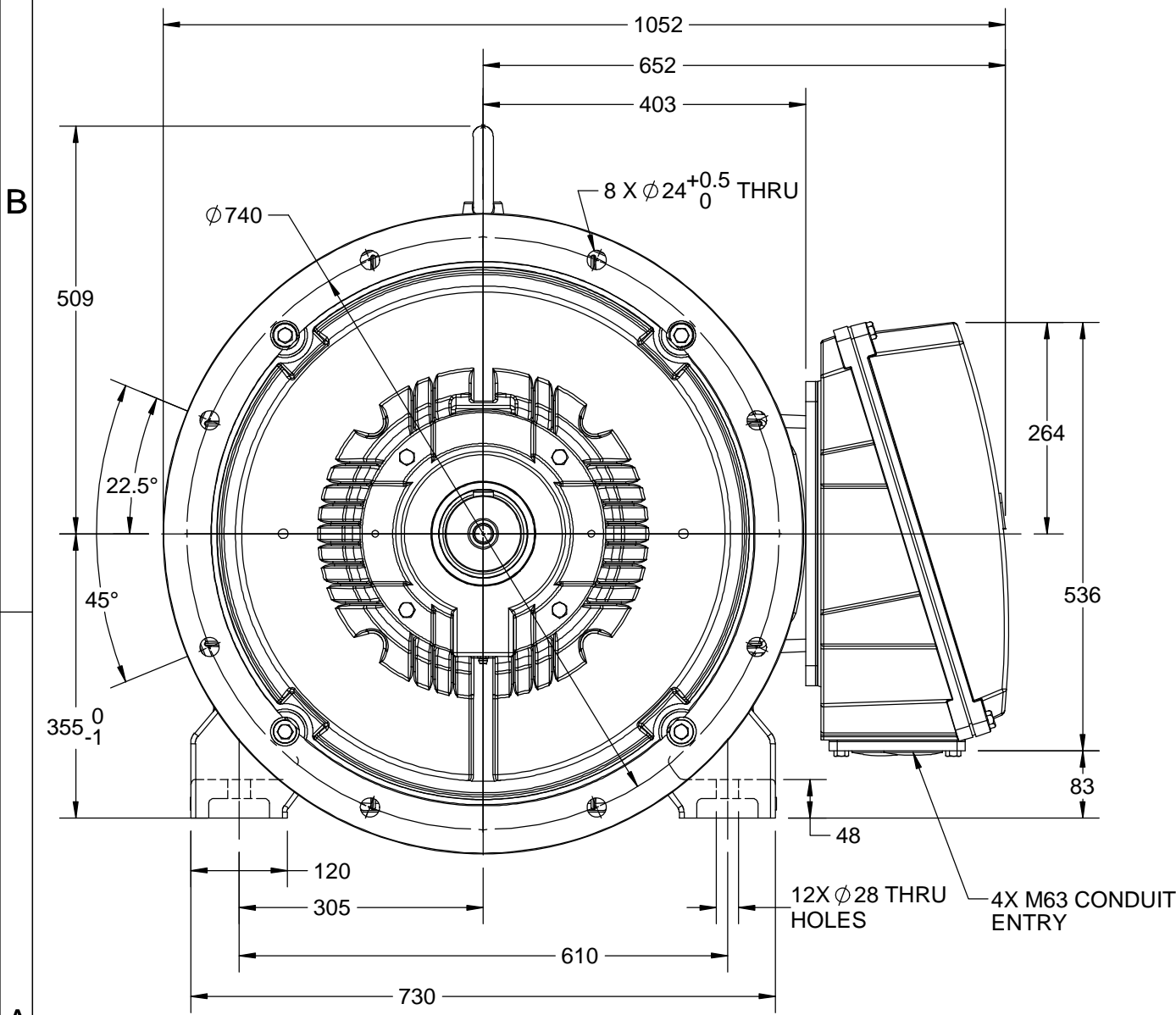

DRAWING REVISION B	REVISION BY VS	DATE 05/07/2018
ECO ECO-0148344	APPROVED BY SBD	DATE 05/07/2018
ECO DESCRIPTION MODEL UPDATED		
<small>COPYRIGHT REGAL BELOIT AMERICA, INC. ALL RIGHTS RESERVED. PROPRIETARY AND CONFIDENTIAL INFORMATION - THIS DOCUMENT IS THE PROPERTY OF REGAL BELOIT AMERICA, INC. ("OWNER") AND CONTAINS OWNER'S PROPRIETARY INFORMATION. ANY PERSON, CORPORATION OR OTHER FIRM RECEIVING IT IS DEEMED, BY RECEIVING IT, TO AGREE THAT IT, AND/OR ANY PART OF IT, SHALL NOT BE DISCLOSED TO ANY PERSON, CORPORATION OR OTHER ENTITY, DUPLICATED, AND/OR USED, EXCEPT AS EXPRESSLY APPROVED IN WRITING IN ADVANCE BY OWNER. THIS DOCUMENT SHALL BE RETURNED TO OWNER UPON REQUEST. IT MAY BE SUBJECT TO CERTAIN RESTRICTIONS UNDER APPLICABLE EXPORT CONTROL LAWS AND REGULATIONS.</small>		

DRAWN BY GSR		
DATE 15/011/2017		
APPROVED BY JAY	DESCRIPTION OUTLINE	
DATE 15/011/2017	355L FR-4~8P-B35 MTG. TCA/QCA-RHS TB	
REFERENCE	MATERIAL	PROCESS/FINISH
THIRD ANGLE PROJECTION	SIZE B	DRAWING NUMBER 0235502333
		SHEET 1 OF 1

COPYRIGHT REGAL BELOIT AMERICA, INC. ALL RIGHTS RESERVED. PROPRIETARY AND CONFIDENTIAL INFORMATION - THIS DOCUMENT IS THE PROPERTY OF REGAL BELOIT AMERICA, INC. ("OWNER") AND CONTAINS OWNER'S PROPRIETARY INFORMATION. ANY PERSON, CORPORATION OR OTHER FIRM RECEIVING IT IS DEEMED, BY RECEIVING IT, TO AGREE THAT IT, AND/OR ANY PART OF IT, SHALL NOT BE DISCLOSED TO ANY PERSON, CORPORATION OR OTHER ENTITY, DUPLICATED, AND/OR USED, EXCEPT AS EXPRESSLY APPROVED IN WRITING IN ADVANCE BY OWNER. THIS DOCUMENT SHALL BE RETURNED TO OWNER UPON REQUEST. IT MAY BE SUBJECT TO CERTAIN RESTRICTIONS UNDER APPLICABLE EXPORT CONTROL LAWS AND REGULATIONS.

DRAWING REVISION <b>A</b>	REVISION BY <b>SN</b>	DATE <b>13/01/2017</b>
ECO <b>ECO-0116390</b>	APPROVED BY <b>SBD</b>	DATE <b>13/01/2017</b>
ECO DESCRIPTION <b>NEW DRAWING RELEASE</b>		

GEOMETRIC TOLERANCE		
LINEAR DIM	>0~6	±0.1
	>6~30	±0.2
	>30~120	±0.3



**NOTES:**

1. PRESSURE-SENSITIVE ADHESIVE COATED PAPER ON THE BACK OF SELF-ADHESIVE.
2. AT THE END OF YELLOW, WORDS, SYMBOLS, LETTERS ARE BLACK, BORDER IS BLACK.
3. THE TOLERANCE OF THE LINEAR SIZE OF THE TOLERANCE WITHOUT THE TOLERANCE BY THE TABLE.

8WD.442.2017



DRAWN BY <b>SN</b>	DATE <b>16/12/2016</b>		 <b>Regal Beloit America, Inc.</b>
	APPROVED BY <b>SBD</b>		
	DATE <b>16/12/2016</b>		DESCRIPTION <b>CONN DIAGRAM-NAMEPLATE</b>
	REFERENCE	MATERIAL	PROCESS/FINISH
	THIRD ANGLE PROJECTION 	SIZE <b>A</b>	DRAWING NUMBER <b>8442000085</b>

**Model No.** SCA1504A4133GAA001

U (V)	$\Delta$ / Y Conn	f [Hz]	P [kW]	P [hp]	I [A]	n [RPM]	T [Nm]	IE Class	% EFF at __ load				PF at __ load			$I_A/I_N$ [pu]	$T_A/T_N$ [pu]	$T_K/T_N$ [pu]
									5/4FL	FL	3/4FL	1/2FL	FL	3/4FL	1/2FL			
380/660	$\Delta$	50	150	200	299.2	742	1919.6	IE2	-	92.9	92.9	94.7	0.82	0.79	0.7	6	1.5	2.4

Motor type	SCA	Degree of protection	IP 55
Enclosure	TEFC	Mounting type	IM B35
Frame Material	Cast Iron	Cooling method	IC 411
Frame size	355M	Motor weight - approx.	1670 kg
Duty	S1	Gross weight - approx.	1715 kg
Voltage variation *	$\pm 10\%$	Motor inertia	9.9098 kgm <sup>2</sup>
Frequency variation *	$\pm 5\%$	Load inertia	Customer to Provide
Combined variation *	10%	Vibration level	2.8 mm/s
Design	N	Noise level ( 1meter distance from motor)	65 dB(A)
Service factor	1.0	No. of starts hot/cold/Equally spread	2/3/4
Insulation class	F	Starting method	DOL
Ambient temperature	-20 to +40 °C	Type of coupling	Direct
Temperature rise (by resistance)	80 [ Class B ] K	LR withstand time (hot/cold)	30/15 s
Altitude above sea level	1000 meter	Direction of rotation	Bi-directional
Hazardous area classification	NA	Standard rotation	Clockwise form DE
Zone classification	NA	Paint shade	RAL 5014
Gas group	NA	Accessories	
Temperature class	NA	Accessory - 1	-
Rotor type	Aluminum Die cast	Accessory - 2	-
Bearing type	Anti-friction ball	Accessory - 3	-
DE / NDE bearing	6322 C3/ 6322 C3	Terminal box position	RHS
Lubrication method	Re-grease-able	Maximum cable size/conduit size	1R x 3C x 300mm <sup>2</sup> /4 x M63 x 1.5
Type of grease	CHEVRON SRI-2 or Equivalent	Auxiliary terminal box	Available on Request

 $I_A/I_N$  - Locked Rotor Current / Rated Current

 $T_K/T_N$  - Breakdown Torque / Rated Torque

 $T_A/T_N$  - Locked Rotor Torque / Rated Torque

**NOTE**

All performance values at rated voltage and frequency.

All performance parameters are subjected to standard tolerance as per IEC 60034-1

\* Voltage, Frequency and combine variation are as per IEC60034-1

Technical data are subject to change. There may be discrepancies between calculated and name plate values.

Efficiency Standards	Europe	China	India	Aus/Nz	Brazil	Global IEC
	-	GB 18613-2012 Grade 2	-	-	-	IEC: 60034-30