

# PRODUCT INFORMATION PACKET

marathon®  
Motors

Model No: SCA0551A1113GAA001

Catalog No: SCA0551A1113GAA001

TerraMAX® Cast Iron Motor, 75 HP, 3 Ph, 50 Hz, 400 V, 3000 RPM, 250M Frame, TEFC



Regal and Marathon are trademarks of Regal Rexnord Corporation or one of its affiliated companies.

©2022 Regal Rexnord Corporation, All Rights Reserved. MC017097E

RegalRexnord

### Nameplate Specifications

Output HP	<b>75 Hp</b>	Output KW	<b>55.0 kW</b>
Frequency	<b>50 Hz</b>	Voltage	<b>400 V</b>
Current	<b>95.7 A</b>	Speed	<b>2973 rpm</b>
Service Factor	<b>1</b>	Phase	<b>3</b>
Efficiency	<b>93.2 %</b>	Power Factor	<b>0.89</b>
Duty	<b>S1</b>	Insulation Class	<b>F</b>
Frame	<b>250M</b>	Enclosure	<b>Totally Enclosed Fan Cooled</b>
Thermal Protection	<b>No Protection</b>	Ambient Temperature	<b>40 °C</b>
Drive End Bearing Size	<b>6314</b>	Opp Drive End Bearing Size	<b>6314</b>
UL	<b>No</b>	CSA	<b>No</b>
CE	<b>Yes</b>	IP Code	<b>55</b>
Number of Speeds	<b>1</b>	Efficiency Class	<b>IE2</b>

### Technical Specifications

Electrical Type	<b>Squirrel Cage</b>	Starting Method	<b>Direct On Line</b>
Poles	<b>2</b>	Rotation	<b>Bi-Directional</b>
Mounting	<b>B3</b>	Motor Orientation	<b>Horizontal</b>
Drive End Bearing	<b>C3</b>	Opp Drive End Bearing	<b>C3</b>
Frame Material	<b>Cast Iron</b>	Shaft Type	<b>Keyed</b>
Overall Length	<b>941 mm</b>	Frame Length	<b>460 mm</b>
Shaft Diameter	<b>60 mm</b>	Shaft Extension	<b>140 mm</b>
Assembly/Box Mounting	<b>R Side</b>		
Outline Drawing	<b>0225000738</b>	Connection Drawing	<b>8442000085</b>

This is an uncontrolled document once printed or downloaded and is subject to change without notice. Date Created:12/01/2022

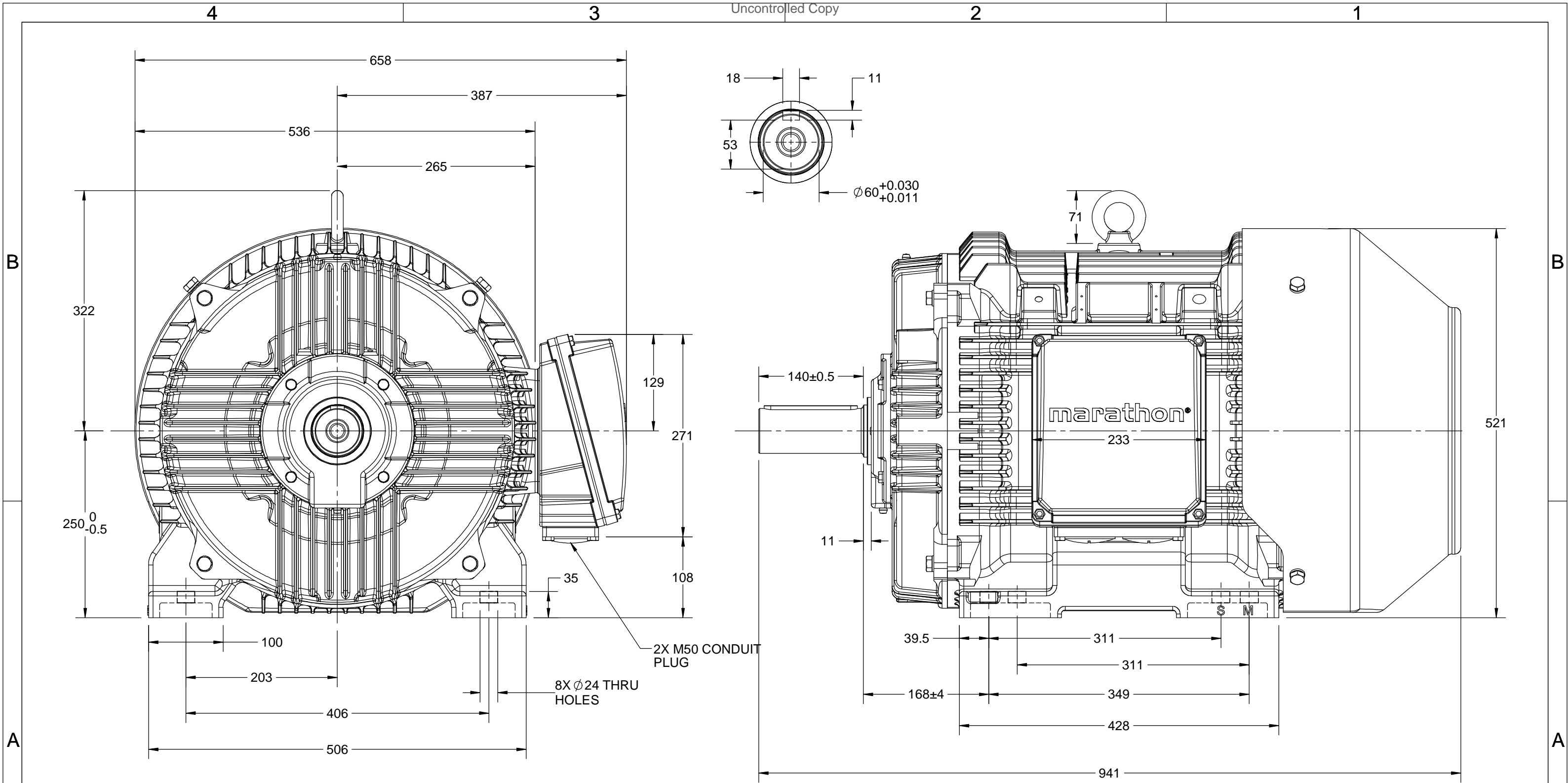

DRAWING REVISION A	REVISION BY A. KEETHA	DATE 12/11/2018
ECO ECO-0153779	APPROVED BY JAY	DATE 12/11/2018
ECO DESCRIPTION <b>NEW DRAWING RELEASE</b> COPYRIGHT REGAL BELOIT AMERICA, INC. ALL RIGHTS RESERVED. PROPRIETARY AND CONFIDENTIAL INFORMATION - THIS DOCUMENT IS THE PROPERTY OF REGAL BELOIT AMERICA, INC. ("OWNER") AND CONTAINS OWNER'S PROPRIETARY INFORMATION. ANY PERSON, CORPORATION OR OTHER FIRM RECEIVING IT IS DEEMED, BY RECEIVING IT, TO AGREE THAT IT, AND/OR ANY PART OF IT, SHALL NOT BE DISCLOSED TO ANY PERSON, CORPORATION OR OTHER ENTITY, DUPLICATED, AND/OR USED, EXCEPT AS EXPRESSLY APPROVED IN WRITING IN ADVANCE BY OWNER. THIS DOCUMENT SHALL BE RETURNED TO OWNER UPON REQUEST. IT MAY BE SUBJECT TO CERTAIN RESTRICTIONS UNDER APPLICABLE EXPORT CONTROL LAWS AND REGULATIONS.		



DRAWN BY A. KEETHA	<b>marathon™</b> Motors	
DATE 12/11/2018		
APPROVED BY JAY	DESCRIPTION <b>OUTLINE</b> 250M FRAME-2P-B3 MTG. MOTOR TYPE:SCA RHS TB	
DATE 12/11/2018	MATERIAL	PROCESS/FINISH
REFERENCE	SIZE <b>B</b>	DRAWING NUMBER <b>0225000738</b>
THIRD ANGLE PROJECTION	SHEET 1 OF 1	

COPYRIGHT REGAL BELOIT AMERICA, INC. ALL RIGHTS RESERVED. UNAUTHORIZED REPRODUCTION OR DISTRIBUTION OF THIS DOCUMENT IS PROHIBITED. REGAL BELOIT AMERICA, INC. ("OWNER") AND CONTAINS OWNER'S PROPRIETARY INFORMATION. ANY PERSON, CORPORATION OR OTHER FIRM RECEIVING IT IS DEEMED, BY RECEIVING IT, TO AGREE THAT IT, AND/OR ANY PART OF IT, SHALL NOT BE DISCLOSED TO ANY PERSON, CORPORATION OR OTHER ENTITY, DUPLICATED, AND/OR USED, EXCEPT AS EXPRESSLY APPROVED IN WRITING IN ADVANCE BY OWNER. THIS DOCUMENT SHALL BE RETURNED TO OWNER UPON REQUEST. IT MAY BE SUBJECT TO CERTAIN RESTRICTIONS UNDER APPLICABLE EXPORT CONTROL LAWS AND REGULATIONS.

DRAWING REVISION <b>A</b>	REVISION BY <b>SN</b>	DATE <b>13/01/2017</b>
ECO <b>ECO-0116390</b>	APPROVED BY <b>SBD</b>	DATE <b>13/01/2017</b>
ECO DESCRIPTION <b>NEW DRAWING RELEASE</b>		

GEOMETRIC TOLERANCE		
LINEAR DIM	>0~6	±0.1
	>6~30	±0.2
	>30~120	±0.3



**NOTES:**

1. PRESSURE-SENSITIVE ADHESIVE COATED PAPER ON THE BACK OF SELF-ADHESIVE.
2. AT THE END OF YELLOW, WORDS, SYMBOLS, LETTERS ARE BLACK, BORDER IS BLACK.
3. THE TOLERANCE OF THE LINEAR SIZE OF THE TOLERANCE WITHOUT THE TOLERANCE BY THE TABLE.

8WD.442.2017



DRAWN BY <b>SN</b>	DATE <b>16/12/2016</b>		 <b>Regal Beloit America, Inc.</b>	
	APPROVED BY <b>SBD</b>	DESCRIPTION <b>CONN DIAGRAM-NAMEPLATE</b>		
	DATE <b>16/12/2016</b>	REFERENCE	MATERIAL	PROCESS/FINISH
	THIRD ANGLE PROJECTION 	SIZE <b>A</b>	DRAWING NUMBER <b>8442000085</b>	SHEET <b>1 OF 1</b>