

# PRODUCT INFORMATION PACKET

marathon®  
Motors

Model No: QCA1604A1113GAA001

Catalog No: QCA1604A1113GAA001

TerraMAX® Cast Iron Motor, 215 HP, 3 Ph, 50 Hz, 400 V, 750 RPM, 355M Frame, TEFC



Regal and Marathon are trademarks of Regal Rexnord Corporation or one of its affiliated companies.

©2022 Regal Rexnord Corporation, All Rights Reserved. MC017097E

RegalRexnord

### Nameplate Specifications

Output HP	<b>215 Hp</b>	Output KW	<b>160.0 kW</b>
Frequency	<b>50 Hz</b>	Voltage	<b>400 V</b>
Current	<b>296.3 A</b>	Speed	<b>742 rpm</b>
Service Factor	<b>1</b>	Phase	<b>3</b>
Efficiency	<b>95.1 %</b>	Power Factor	<b>0.82</b>
Duty	<b>S1</b>	Insulation Class	<b>F</b>
Frame	<b>355M</b>	Enclosure	<b>Totally Enclosed Fan Cooled</b>
Thermal Protection	<b>No Protection</b>	Ambient Temperature	<b>40 °C</b>
Drive End Bearing Size	<b>6322</b>	Opp Drive End Bearing Size	<b>6322</b>
UL	<b>No</b>	CSA	<b>No</b>
CE	<b>Yes</b>	IP Code	<b>55</b>
Number of Speeds	<b>1</b>	Efficiency Class	<b>IE4</b>

### Technical Specifications

Electrical Type	<b>Squirrel Cage</b>	Starting Method	<b>Direct On Line</b>
Poles	<b>8</b>	Rotation	<b>Bi-Directional</b>
Mounting	<b>B3</b>	Motor Orientation	<b>Horizontal</b>
Drive End Bearing	<b>C3</b>	Opp Drive End Bearing	<b>C3</b>
Frame Material	<b>Cast Iron</b>	Shaft Type	<b>Keyed</b>
Overall Length	<b>1542 mm</b>	Frame Length	<b>1010 mm</b>
Shaft Diameter	<b>95 mm</b>	Shaft Extension	<b>170 mm</b>
Assembly/Box Mounting	<b>R Side</b>		
Connection Drawing	<b>8442000085</b>	Outline Drawing	<b>0235502296</b>

This is an uncontrolled document once printed or downloaded and is subject to change without notice. Date Created:12/01/2022

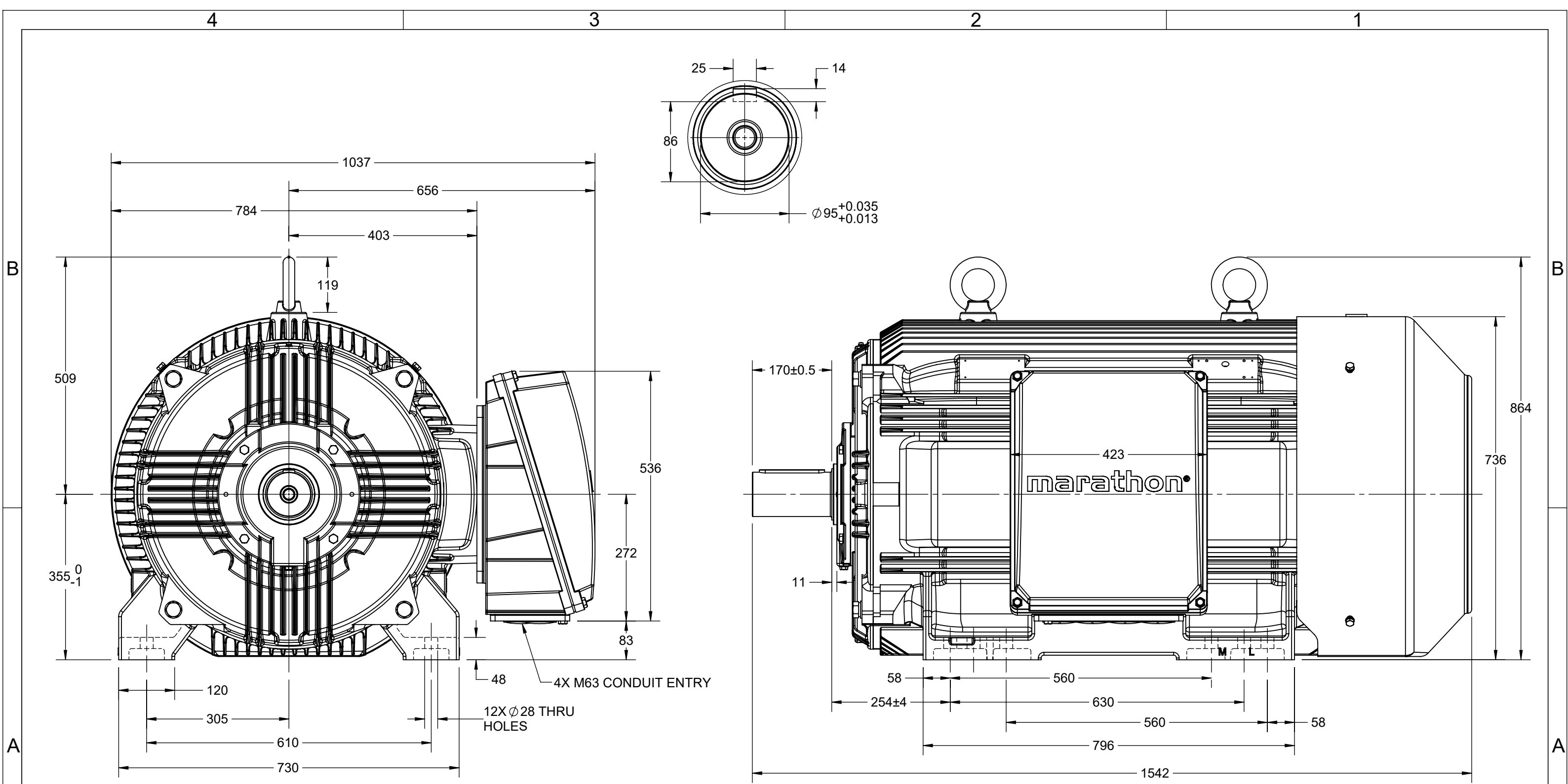

DRAWING REVISION C	REVISION BY LK	DATE 07/09/2020
ECO CR-0000087	APPROVED BY JAY	DATE 07/09/2020
ECO DESCRIPTION <b>MODEL UPDATED</b>		
<small>COPYRIGHT REGAL BELOIT AMERICA, INC. ALL RIGHTS RESERVED.          PROPRIETARY AND CONFIDENTIAL INFORMATION - THIS DOCUMENT IS THE PROPERTY OF          REGAL BELOIT AMERICA, INC. ("OWNER") AND CONTAINS OWNER'S PROPRIETARY          INFORMATION. ANY PERSON, CORPORATION OR OTHER FIRM RECEIVING IT IS DEEMED,          BY RECEIVING IT, TO AGREE THAT IT, AND/OR ANY PART OF IT, SHALL NOT BE DISCLOSED          TO ANY PERSON, CORPORATION OR OTHER ENTITY, DUPLICATED, AND/OR USED, EXCEPT          AS EXPRESSLY APPROVED IN WRITING IN ADVANCE BY OWNER. THIS DOCUMENT SHALL          BE RETURNED TO OWNER UPON REQUEST. IT MAY BE SUBJECT TO CERTAIN          RESTRICTIONS UNDER APPLICABLE EXPORT CONTROL LAWS AND REGULATIONS.</small>		

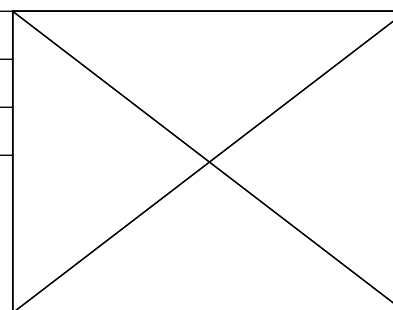

DRAWN BY SKM		
DATE 11/08/2017		
APPROVED BY JAY	DESCRIPTION <b>OUTLINE</b>	
DATE 11/08/2017	355L-4~8P-B3	
REFERENCE	MATERIAL	PROCESS/FINISH
THIRD ANGLE PROJECTION	SIZE B	DRAWING NUMBER 0235502296
		SHEET 1 OF 1



Model No. QCA1604A1113GAA001

U (V)	Δ / Y Conn	f [Hz]	P		I [A]	n [RPM]	T [Nm]	IE Class	% EFF at __ load				PF at __ load			I <sub>A</sub> /I <sub>N</sub> [pu]	T <sub>A</sub> /T <sub>N</sub> [pu]	T <sub>K</sub> /T <sub>N</sub> [pu]
			[kW]	[hp]					5/4FL	FL	3/4FL	1/2FL	FL	3/4FL	1/2FL			
400	Δ	50	160	215	296.1	742	2063.03	IE4	-	95.1	95.1	94.8	0.82	0.79	0.69	6.2	1.6	2.5

Motor type	QCA	Degree of protection	IP 55
Enclosure	TEFC	Mounting type	IM B3
Frame Material	Cast Iron	Cooling method	IC 411
Frame size	355M	Motor weight - approx.	1795 kg
Duty	S1	Gross weight - approx.	1840 kg
Voltage variation *	± 10%	Motor inertia	10.5659 kgm <sup>2</sup>
Frequency variation *	± 5%	Load inertia	Customer to Provide
Combined variation *	10%	Vibration level	2.8 mm/s
Design	N	Noise level ( 1meter distance from motor)	65 dB(A)
Service factor	1.0	No. of starts hot/cold/Equally spread	2/3/4
Insulation class	F	Starting method	DOL
Ambient temperature	-20 to +40 °C	Type of coupling	Direct
Temperature rise (by resistance)	80 [ Class B ] K	LR withstand time (hot/cold)	15/30 s
Altitude above sea level	1000 meter	Direction of rotation	Bi-directional
Hazardous area classification	NA	Standard rotation	Clockwise form DE
Zone classification	NA	Paint shade	RAL 5014
Gas group	NA	Accessories	
Temperature class	NA	Accessory - 1	PTC 150°C
Rotor type	Aluminum Die cast	Accessory - 2	-
Bearing type	Anti-friction ball	Accessory - 3	-
DE / NDE bearing	6322 C3 / 6322 C3	Terminal box position	RHS
Lubrication method	Regreasable	Maximum cable size/conduit size	1R x 3C x 300mm <sup>2</sup> /4 x M63 x 1.5
Type of grease	CHEVRON SRI-2 or Equivalent	Auxiliary terminal box	NA

I<sub>A</sub>/I<sub>N</sub> - Locked Rotor Current / Rated Current

T<sub>K</sub>/T<sub>N</sub> - Breakdown Torque / Rated Torque

T<sub>A</sub>/T<sub>N</sub> - Locked Rotor Torque / Rated Torque

**NOTE**

All performance values at rated voltage and frequency.

All performance parameters are subjected to standard tolerance as per IEC 60034-1

\* Voltage, Frequency and combined variation are as per IEC60034-1

Technical data are subject to change. There may be slight variations between calculated values in this datasheet and the motor nameplate figures.

Efficiency Standards	Europe IEC 60034-30-1	China -	India -	Aus/Nz AS/NZ 1359:5:2004	Brazil -	Global IEC IEC:60034-30-1



Model No. QCA1604A1113GAA001

Enclosure	U (V)	Δ / Y Conn	f [Hz]	P [kW]	P [hp]	I [A]	n [RPM]	T [kgm]	T [Nm]	IE Class	Amb [°C]	Duty	Elevation [m]	Inertia [kg-m <sup>2</sup> ]	Weight [kg]
TEFC	400	Δ	50	160	215	296.1	742	210.37	2063.03	IE4	40	S1	1000	10.5659	1795

**Motor Load Data**

Load Point		NL	1/4FL	1/2FL	3/4FL	FL	5/4FL
Current	A	106.6	126.2	178.3	234.0	296.1	
Torque	Nm	0.0	510.7	1026.1	1543.0	2063.0	
Speed	r/min	750	748	746	745	742	
Efficiency	%	0.0	92.0	94.8	95.1	95.1	
Power Factor	%	4.3	49.8	69.0	79.0	82.0	

**Performance vs Load Chart**

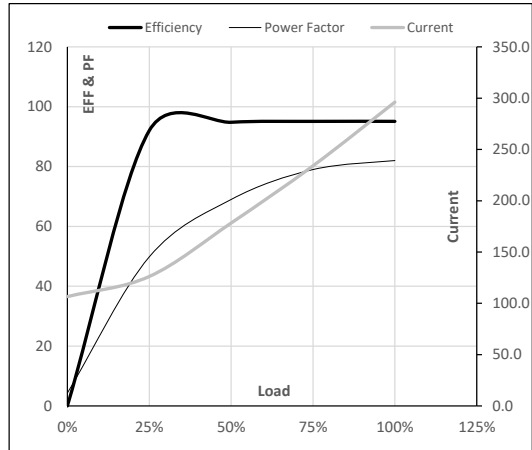

**Motor Speed Torque Data**

Load Point		LR	P-Up	BD	Rated	NL
Speed	r/min	0	107	683	742	750
Current	A	1836.1	1652.5	988.5	296.1	106.6
Torque	pu	1.6	1.3	2.5	1	0

**Starting Characteristics Chart**

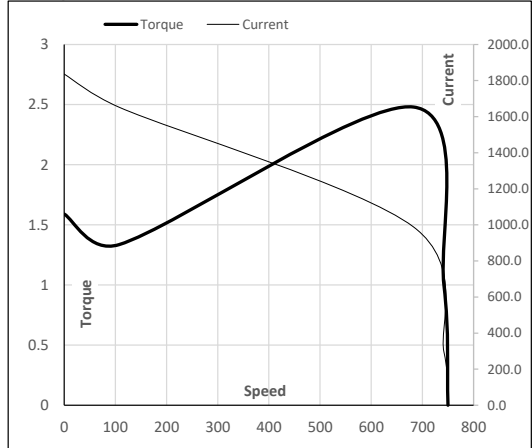

**NOTE** Refer data sheet for applicable standard and tolerances on performance parameters

Issued By  
Issued Date



**Model No.** QCA1604A1113GAA001

Enclosure	U (V)	Δ / Y Conn	f [Hz]	P [kW]	P [hp]	I [A]	n [rpm]	T [kgm]	T [Nm]	IE Class	Amb [°C]	Duty	Elevation [m]	Inertia [kg-m <sup>2</sup> ]	Weight [kg]
TEFC	400	Δ	50	160	215	296.1	742	210.37	2063.03	IE4	40	S1	1000	10.5659	1795

**Motor Speed Torque Data**

Load	FL	I <sub>1</sub>	I <sub>2</sub>	I <sub>3</sub>	I <sub>4</sub>	I <sub>5</sub>	LR
TWT Hot	s 10000	47	31	25	18	16	15
TWT Cold	s 10000	93	62	45	36	34	30
Current	pu	1	2	3	4	5	5.5

**Thermal Characteristics Chart**

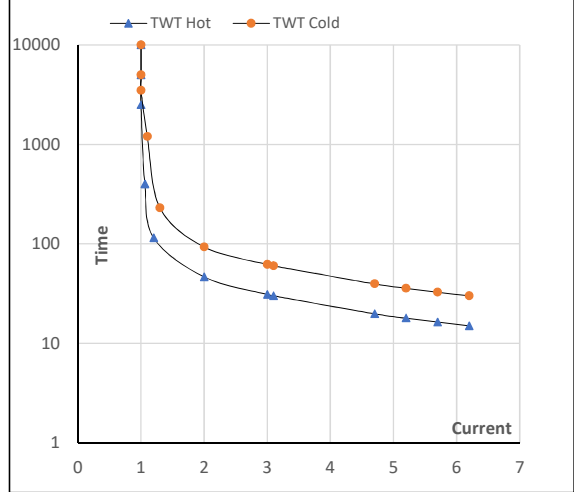

**NOTE** Refer data sheet for applicable standard and tolerances on performance parameters

Issued By  
Issued Date

