

PRODUCT INFORMATION PACKET



Model No: LM80159
Catalog No: LM80159
250 HP, Fire Pump Motors, 3 phase, 3600 RPM, 400 V, 445TS Frame, DP
Fire Pump Motors



Regal and Leeson are trademarks of Regal Rexnord Corporation or one of its affiliated companies.
©2021 Regal Rexnord Corporation, All Rights Reserved. MC017097E





Nameplate Specifications

Output HP	250 Hp	Output KW	187.0 kW
Frequency	60 Hz	Voltage	400 V
Current	321.0 A	Speed	3565 rpm
Service Factor	1.15	Phase	3
Efficiency	94.5 %	Power Factor	88.5
Duty	Continuous	Insulation Class	F
Design Code	B	KVA Code	F
Frame	445TS	Enclosure	Drip Proof
Thermal Protection	No	Ambient Temperature	40 °C
Drive End Bearing Size	6313	Opp Drive End Bearing Size	6313
UL	No	CSA	Y
CE	Y	IP Code	12
Number of Speeds	1		

Technical Specifications

Electrical Type	Squirrel Cage Induction Run	Starting Method	Part Wdg Start & Wye Start Delta Run
Poles	2	Rotation	Reversible
Resistance Main	.0198 Ohms	Mounting	Rigid Base
Motor Orientation	Horizontal	Drive End Bearing	Ball
Opp Drive End Bearing	Ball	Frame Material	Cast Iron
Shaft Type	TS	Overall Length	36.00 in
Frame Length	20.52 in	Shaft Diameter	2.375 in
Shaft Extension	4.75 in	Assembly/Box Mounting	F1/F2 CAPABLE
Connection Drawing	A-EE7300BH-LN	Outline Drawing	B-SS509642LN-2050

This is an uncontrolled document once printed or downloaded and is subject to change without notice. Date Created:11/30/2021

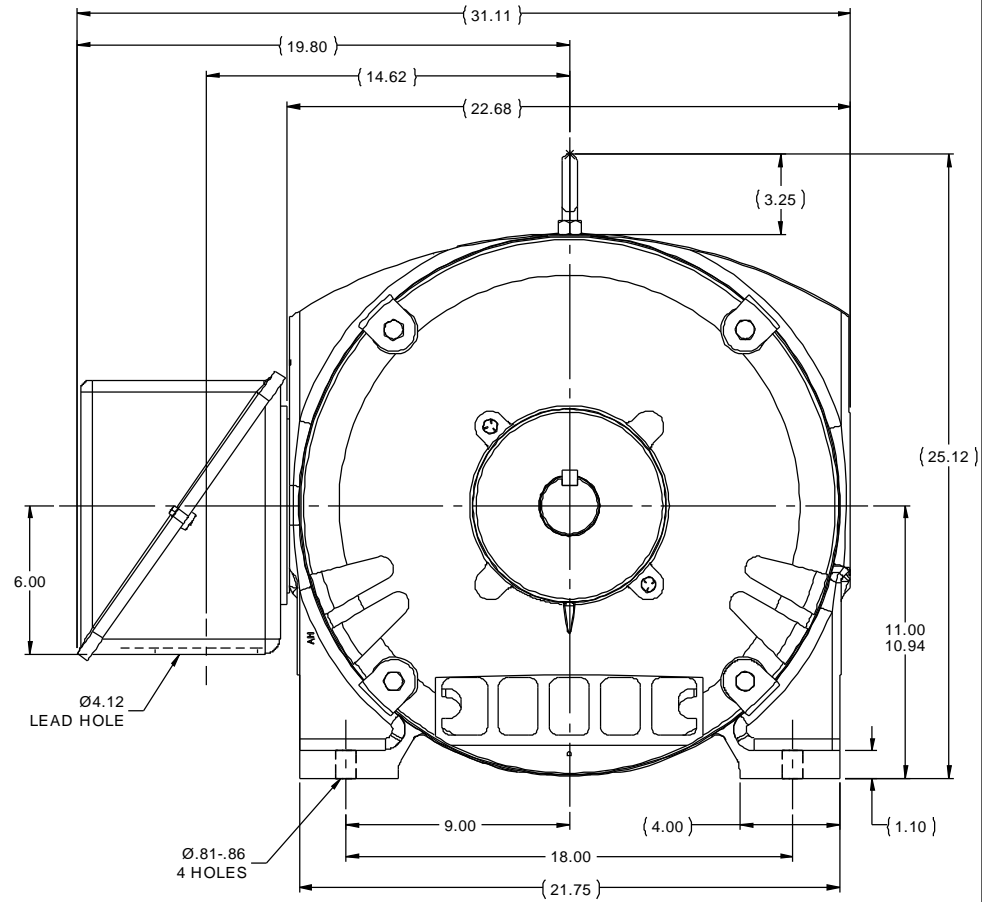
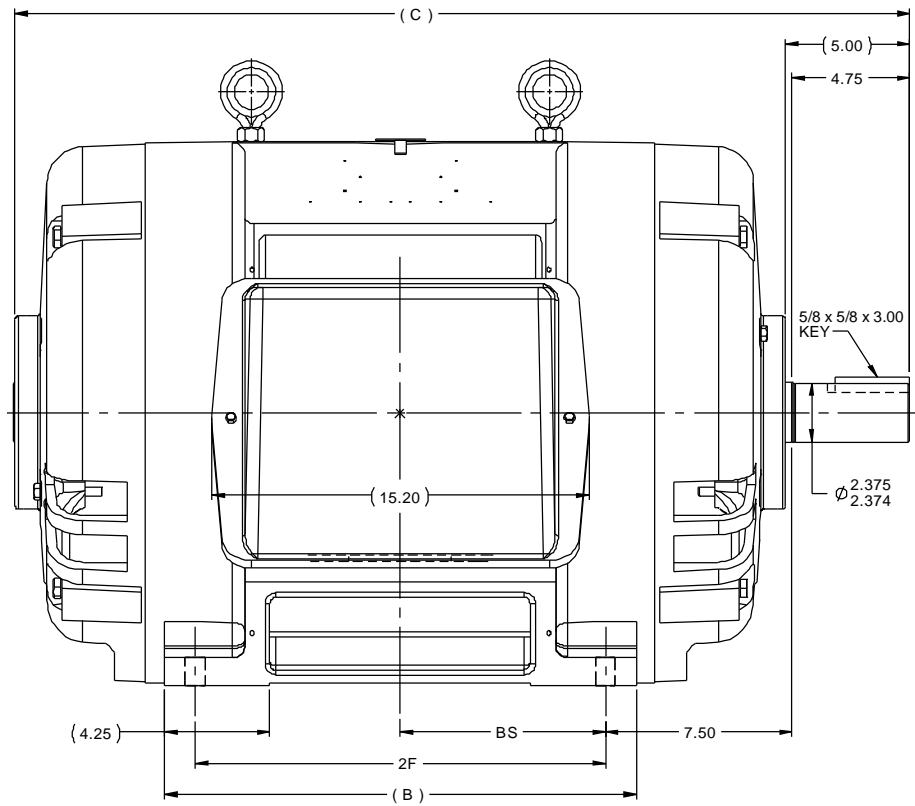

NOTES:

1. CONDUIT BOX CAN BE ROTATED IN 90° STEPS.
2. CONDUIT BOX CAN BE MOUNTED ON OPPOSITE SIDE BY REMOVING BRACKETS AND TURNING FRAME 180°.
3. NAMEPLATES TO BE READ FROM CONDUIT BOX SIDE OF MOTOR.

DASH	FRAME	B	C	2F	BS
1850	444TS	17.00	34.00	14.50	7.25
2050	445TS	19.00	36.00	16.50	8.25

		TOLERANCES UNLESS SPECIFIED				DRAWN KL 07-31-2007	
		DEC INCHES				CHK GFH 07-31-2003	
		X ±.1		APPR JES 07-31-2003		SCALE 1:5	
2		UPDATED TO CURRENT STD'S. MU114528		JJB 08-01-2013 TDB		TITLE OUTLINE	
1		NEW DRAWING MU47677		KL 07-31-2007		444/445TS FR. - DR. PR. STD.	
NO		REVISION		CHK		MAY ±1/2° FINISH	
		THIRD ANGLE PROJECTION		RFP 07-31-2003		PREV	
				NETWORK FILE NAME SS509642LN		PAGE OF	
				SIZE B		DRAWING NO SS509642LN	
						REV 2	

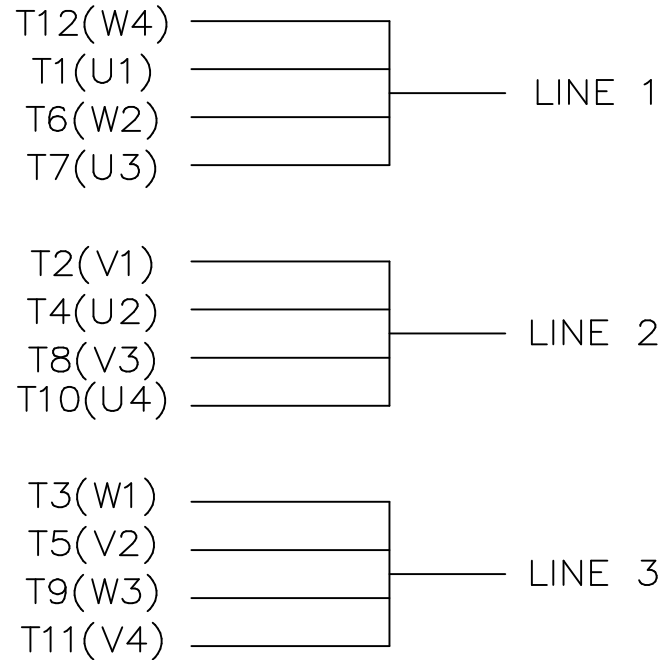
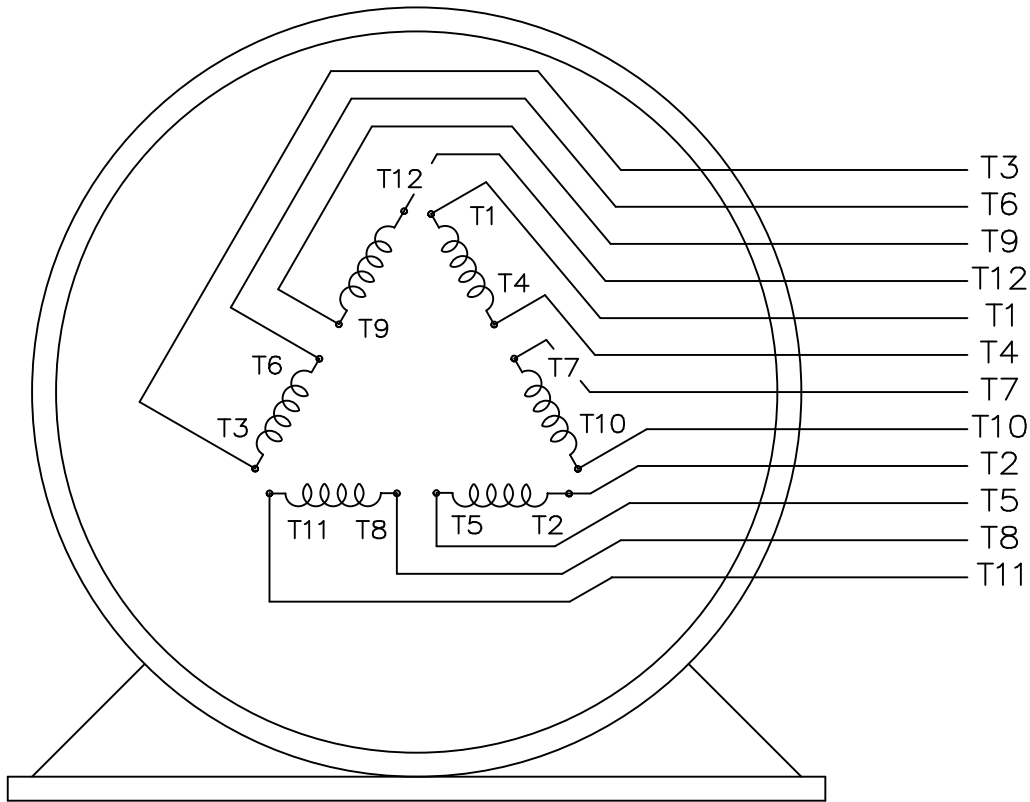

VIEW OF TERMINAL END

				TOLERANCES UNLESS SPECIFIED			DRAWN KL 04-23-2002		
				DEC.	INCHES		CHK DJK 04-24-2002		
				.X	±.1		APPD EAB 04-24-2002		
				.XX	±.01		SCALE 1=1		
2	ADDED IEC TERMINAL MARKINGS	CN 41429	JJB 05/24/2007	ML	.XXX	±.005	TITLE CONNECTION DIAGRAM - EXTERNAL 12 LEAD - SINGLE VOLTAGE		
1	NEW DRAWING	MU41562	KL 04-12-02		.XXXX	±.0005	MAT'L.		
NO.	REVISION		BY & DATE	CHK	ANG	±1/2"	FINISH		
THIS DRAWING IN DESIGN AND DETAIL IS OUR PROPERTY AND MUST NOT BE USED EXCEPT IN CONNECTION WITH OUR WORK ALL RIGHTS OF DESIGN AND INVENTION ARE RESERVED THIS IS AN ELECTRONICALLY GENERATED DOCUMENT - DO NOT SCALE THIS PRINT				RFP	CAD FILE ee7300bh_ln		SIZE	DRAWING NO. PAGE OF	REV.
				DIST	WA-SB		A	EE7300BH-LN 2	2



1051 CHEYENNE AVE.
GRAFTON, WI 53024
PH. 262-277-8810

DATA VOLTS: 460

CERTIFICATION DATA SHEET

CONN. DIAGRAM: A-EE7300BH-LN
OUTLINE: B-SS509642LN-2050
WINDING: T445239

CAT #: LM80159

NONE 6

TYPICAL MOTOR PERFORMANCE DATA

HP	KW	SYNC RPM	FL RPM	FRAME	ENCLOSURE	TYPE	KVA CODE	DESIGN
250	187	3600	3565	445TS	DP	TDS	F	B

PH	HZ	VOLTS	AMPS	START TYPE	DUTY	INSL	S.F.	AMB	ELEV.
3	60	400	321	PWS & YDRUN	CONT	F	1.15	40	3300

F.L. EFF	94.5	3/4 LD EFF	94.5	1/2 LD EFF	93.6	GTD EFF	ELECT. TYPE
F.L. PF	88.5	3/4 LD PF	87.5	1/2 LD PF	83.0	93.6	SQ CAGE IND RUN

F.L. TORQUE	LR AMPS @ 460 V	L.R. TORQUE	B.D. TORQUE	F.L. RISE (° C)
368 LB-FT	1,955	575 LB-FT 156%	900 LB-FT 245%	50

PRESSURE @ 3	SOUND	POWER	ROTOR WK²	MAX. LOAD WK²	SAFE STALL TIME	STARTS/HOUR	MOTOR WGT
84 dBA	93 dBA		31.0 LB-FT²	80 LB-FT²	10 SEC.	0	1400 LB.

***** SUPPLEMENTAL INFORMATION *****

DE BRACKET TYPE	ODE BRACKET TYPE	MOUNT TYPE	MOTOR ORIENTATION	SEVERE DUTY	HAZARDOUS LOCATION	DRIP COVER	SCREENS	PAINT
STANDARD	STANDARD	RIGID	HORIZONTAL	NO	NONE	NO	NONE	WATTSAVER

BEARINGS		GREASE	SHAFT TYPE	SPECIAL DE	SPECIAL ODE	SHAFT MATERIAL	FRAME MATERIAL
DE	ODE	POLYREX EM	TS	NONE	NONE	1045 HOT ROLLED (C-204)	CAST IRON
BALL	BALL						
6313	6313						

THERMOSTATS	PROTECTORS	WDG RTD's	BRG RTD's	THERMISTORS	CONTROL	SPACE HEATERS
NONE	NOT	NONE	NONE	NONE	FALSE	NA

R1 (ohms/ph)	R2 (ohms/ph)	X1 (ohms/ph)	X2 (ohms/ph)	Xm (ohms/ph)	VIBRATION (in/sec)	FLOAT
0.012	0.007	0.079	0.071	3.019	0.150	ODE

* N O T E S *	INVERTER TORQUE: NONE INV. HP SPEED RANGE: NONE					
	ENCODER: NONE NONE NONE					
	BRAKE: NONE NONE NONE					
	FT-LB: NA VOLTAGE: NONE					
	UL: NONE					

DATE: 8/31/2018

H2:

Data Sheet

Date: 8/31/2018

LM80159



Data @ **400 V**

Motor Load Data

Load	0%	25%	50%	75%	100%	115%	125%	LR
Current (Amps)	74.8	110	173	244	321	370	403	1,955
Torque (ft-lb)	0.00	94.0	183	275	368	425	462	575
RPM	3600	3590	3580	3572	3565	3,555	3550	0
Efficiency (%)		90.2	93.6	94.5	94.5	94.5	94.1	
P.F. (%)	9.0	67.0	83.0	87.5	88.5	88.5	89.0	32.0

Motor Speed Data

	LR	Pull-Up	BD	Rated	Idle
Speed (RPM)	0	2200	3400	3565	3600
Current (Amps)	1,955	1,811	1,064	321	74.8
Torque (ft-lb)	575	475	900	368	0.00

Information Block				
HP	250.0			
Sync. RPM	3600			
Frame	445			
Enclosure	DP			
Construction	TDS			
Voltage	400 V			
Frequency	60 Hz			
Design	B			
LR Code letter	F			
Service Factor	1.15			
Temp Rise @ FL	50 ° C			
Duty	CONT			
Ambient	40 ° C			
Elevation	1,000 feet			
Rotor/Shaft wk ²	31.0 Lb-Ft ²			
Ref Wdg	T445239 NONE			
Sound Pressure @ 1M	84 dBA			
VFD Rating	NONE			
Outline Dwg	B-SS509642LN-2050			
Conn. Diag	A-EE7300BH-LN			
Additional Specifications:				
0				
0				
EQUIV CKT (OHMS / PHASE)				
R1	R2	X1	X2	Xm
0.0120	0.0070	0.0790	0.0710	3.0190

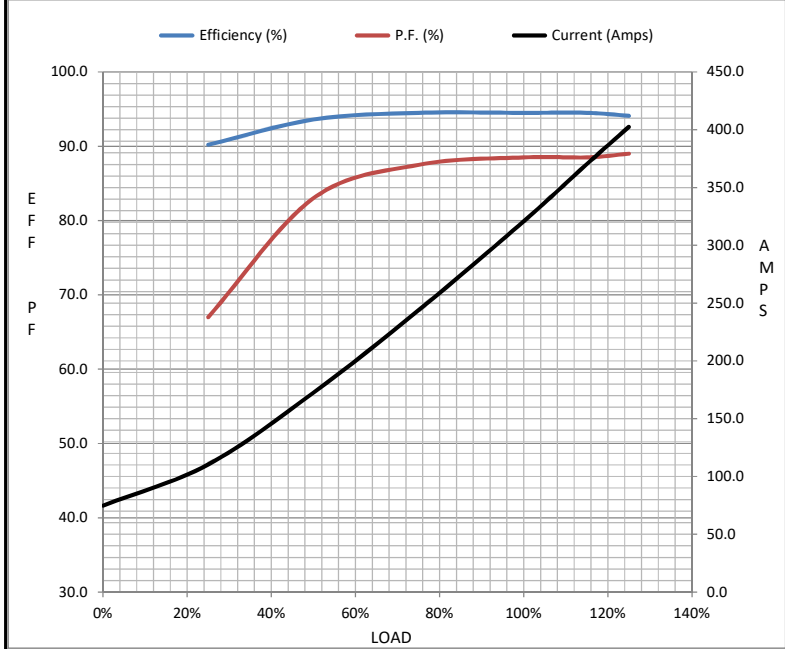

Speed - Torque Curve

