

PRODUCT INFORMATION PACKET



Model No: LM80133
Catalog No: LM80133
75 HP Fire Pump Motor, 3 phase, 1800 RPM, 200/400 V, 365T Frame, ODP
Fire Pump Motors



Regal and Leeson are trademarks of Regal Rexnord Corporation or one of its affiliated companies.
©2021 Regal Rexnord Corporation, All Rights Reserved. MC017097E





Nameplate Specifications

Output HP	75 Hp	Output KW	56.0 kW
Frequency	60 Hz	Voltage	200/400 V
Current	204.0/102.0 A	Speed	1775 rpm
Service Factor	1.15	Phase	3
Efficiency	94.1 %	Power Factor	84
Duty	Continuous	Insulation Class	B
Design Code	B	KVA Code	F
Frame	365T	Enclosure	Drip Proof
Thermal Protection	No	Ambient Temperature	40 °C
Drive End Bearing Size	6314	Opp Drive End Bearing Size	6312
UL	No	CSA	Y
CE	Y	IP Code	12
Number of Speeds	1		

Technical Specifications

Electrical Type	Squirrel Cage Induction Run	Starting Method	Part Wdg Start Low Volt Only & Wye Start Delta Run
Poles	4	Rotation	Reversible
Resistance Main	.095 Ohms	Mounting	Rigid Base
Motor Orientation	Horizontal	Drive End Bearing	Ball
Opp Drive End Bearing	Ball	Frame Material	Cast Iron
Shaft Type	T	Overall Length	29.62 in
Frame Length	15.02 in	Shaft Diameter	2.375 in
Shaft Extension	5.88 in	Assembly/Box Mounting	F1/F2 CAPABLE
Connection Drawing	A-EE7308AA-LN	Outline Drawing	B-SS509461LN-1500

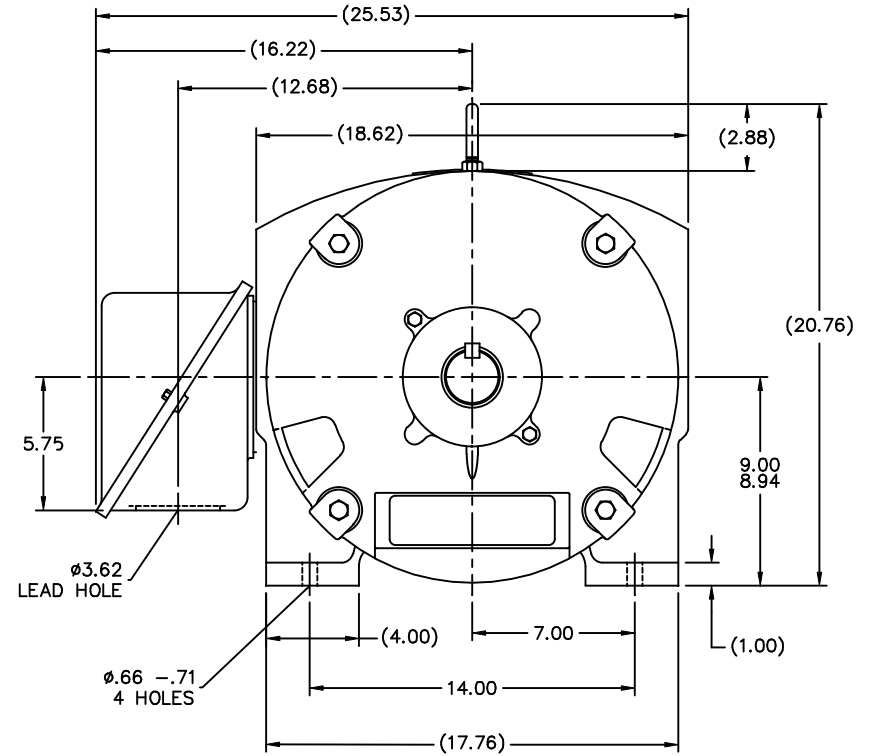
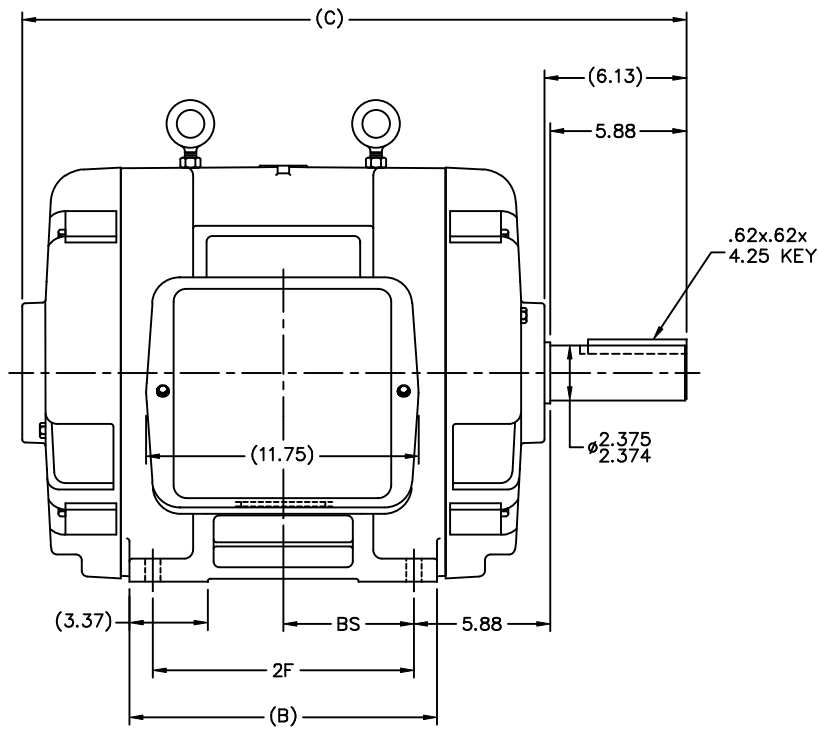

NOTES:

1. CONDUIT BOX CAN BE ROTATED IN 90° STEPS.
2. CONDUIT BOX CAN BE MOUNTED ON OPPOSITE SIDE BY REMOVING BRACKETS AND TURNING FRAME 180°.
3. NAMEPLATE TO BE READ FROM CONDUIT BOX SIDE OF MOTOR.

(B-SS509462)

DASH	FRAME	B	C	2F	BS
1400	364T	13.25	28.62	11.25	5.62
1500	365T	14.25	29.62	12.25	6.12

		TOLERANCES UNLESS SPECIFIED		Lincoln MOTOR		DRAWN KL 10-16-2001	
		DEC.	INCHES			CHK	DJK 10-16-2001
		.X	±.1	TITLE OUTLINE		APPD	MAL 10-16-2001
2	CONVERTED TO AUTOCAD	.XX	±.03	360T FR. - DR.PR.		SCALE	3=16
1	NEW DRAWING MU39335	.XXX	±.005	MATL		REF	
NO.	REVISION	.XXXX	±.0005	FINISH		FMF	
	BY & DATE	CHK	ANG	±7°30"		PREV	
THIS DRAWING IN DESIGN AND DETAIL IS OUR PROPERTY AND MUST NOT BE USED EXCEPT IN CONNECTION WITH OUR WORK ALL RIGHTS OF DESIGN AND INVENTION ARE RESERVED THIS IS AN ELECTRONICALLY GENERATED DOCUMENT - DO NOT SCALE THIS PRINT				RFP	CAD FILE SS509461LN	SIZE	DRAWING NO. PAGE OF REV.
				DIST	WA	B	SS509461LN 2

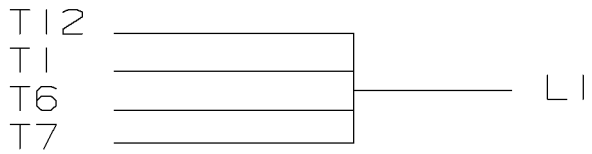

LOW VOLTAGE

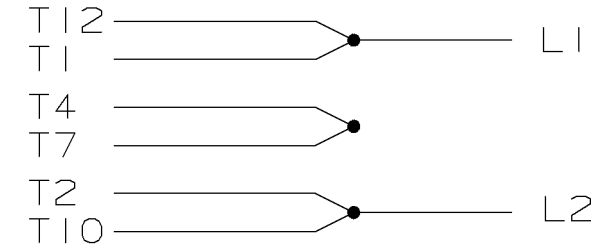

HIGH VOLTAGE

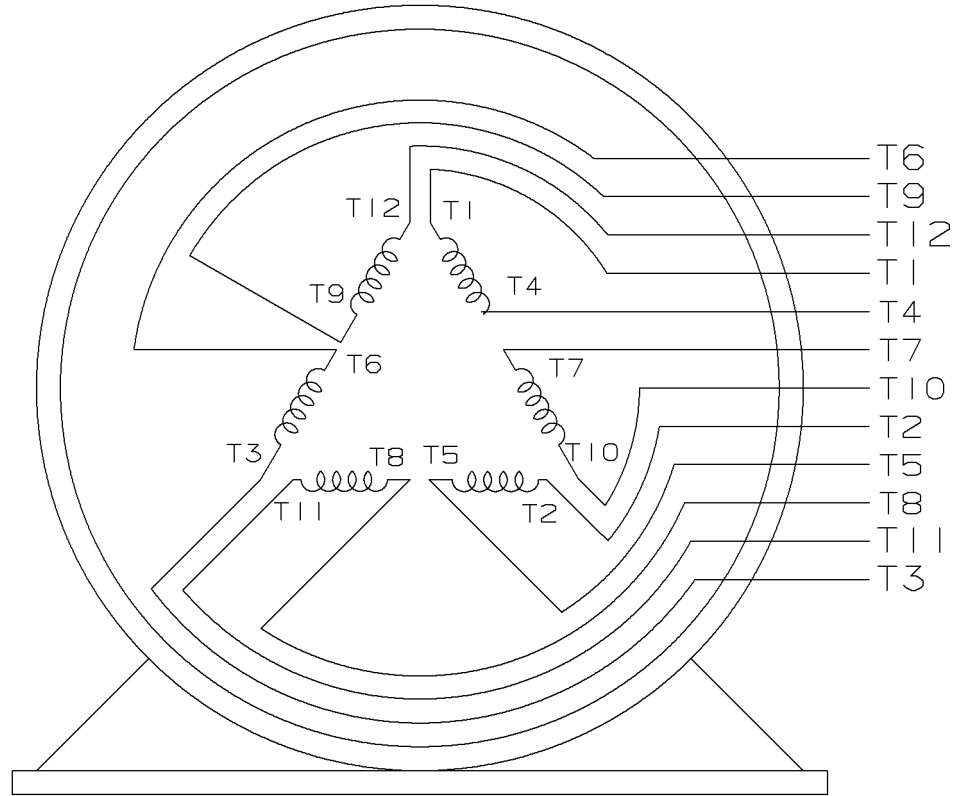

VIEW OF TERMINAL END

					✓ UNLESS OTHERWISE SPECIFIED DIMENSIONS ARE IN INCHES TOL. ON XX±.02 XXX±.005 XXXX±.0005 ANGLES± 7'30"				
2	08-09-1999	RE-ISSUE, ADDED '-' TO PART NUMBER	BLR		MAX. SURFACE ROUGHNESS UNLESS OTHERWISE NOTED		DRAWN BY TRB 07-16-1999		
1	06-18-1999	NEW DRAWING	TRB	FINISH		CHKD BY ML 06-18-1999			
				MATERIAL		APPD BY GK 06-18-1999			
REV	DATE	CHANGE	NAME	PART NAME 3 PHASE CONNECTION DIAGRAM 2/1 DELTA - 12 LEADS			DRWG NO A- EE7308AA-LN		

PURCHASED

CADD FILE NO.

EE7308AALN

ERROR: undefined
OFFENDING COMMAND: Pscrip

STACK:



1051 CHEYENNE AVE.
GRAFTON, WI 53024
PH. 262-277-8810

DATA VOLTS: 460

CERTIFICATION DATA SHEET

CONN. DIAGRAM: A-EE7308AA-LN
OUTLINE: B-SS509461LN-1500
WINDING: T3654176

CAT #: LM80133

NONE 2

TYPICAL MOTOR PERFORMANCE DATA

HP	KW	SYNC RPM	FL RPM	FRAME	ENCLOSURE	TYPE	KVA CODE	DESIGN
75	56	1800	1775	365T	DP	TDS	F	B

PH	HZ	VOLTS	AMPS	START TYPE	DUTY	INSL	S.F.	AMB	ELEV.
3	60	200/400	204/102	PWS(LV ONLY) & YDRU	CONT	B	1.15	40	3300

F.L. EFF	94.1	3/4 LD EFF	94.1	1/2 LD EFF	94.1	GTD EFF	ELECT. TYPE
F.L. PF	84.0	3/4 LD PF	82.0	1/2 LD PF	75.0	93.6	SQ CAGE IND RUN

F.L. TORQUE	LR AMPS @ 460 V	L.R. TORQUE	B.D. TORQUE	F.L. RISE (° C)
222 LB-FT	587	375 LB-FT 169%	490 LB-FT 221%	55

PRESSURE @ 3	SOUND	POWER	ROTOR WK²	MAX. LOAD WK²	SAFE STALL TIME	STARTS/HOUR	MOTOR WGT
75 dBA	84 dBA		13.8 LB-FT²	0 LB-FT²	20 SEC.	0	775 LB.

***** SUPPLEMENTAL INFORMATION *****

DE BRACKET TYPE	ODE BRACKET TYPE	MOUNT TYPE	MOTOR ORIENTATION	SEVERE DUTY	HAZARDOUS LOCATION	DRIP COVER	SCREENS	PAINT
STANDARD	STANDARD	RIGID	HORIZONTAL	NO	NONE	NO	NONE	WATTSAVER

BEARINGS		GREASE	SHAFT TYPE	SPECIAL DE	SPECIAL ODE	SHAFT MATERIAL	FRAME MATERIAL
DE	ODE	POLYREX EM	T	NONE	NONE	1045 HOT ROLLED (C-204)	CAST IRON
BALL	BALL						
6314	6312						

THERMOSTATS	PROTECTORS	WDG RTD's	BRG RTD's	THERMISTORS	CONTROL	SPACE HEATERS
NONE	NOT	NONE	NONE	NONE	FALSE	NA

R1 (ohms/ph)	R2 (ohms/ph)	X1 (ohms/ph)	X2 (ohms/ph)	Xm (ohms/ph)	VIBRATION (in/sec)	FLOAT
0.047	0.031	0.277	0.349	7.037	0.150	ODE

* N O T E S *	INVERTER TORQUE: NONE	
	INV. HP SPEED RANGE: NONE	
	ENCODER: NONE	
	NONE	NONE PPR
	NONE	

DATE: 8/30/2018	BRAKE: NONE	
	NONE	NONE
	FT-LB: NA	
	VOLTAGE: NONE	HZ:
UL: NONE		

Data Sheet

Date: 8/30/2018

LM80133



Data @ **400 V**

Motor Load Data

Load	0%	25%	50%	75%	100%	115%	125%	LR
Current (Amps)	32.8	40.8	56.9	78.2	102	117	129	587
Torque (ft-lb)	0.00	55.0	110	166	222	256	278	375
RPM	1800	1795	1790	1782	1775	1,772	1768	0
Efficiency (%)		91.0	94.1	94.1	94.1	93.6	93.0	
P.F. (%)	5.0	54.5	75.0	82.0	84.0	84.5	84.5	34.0

Motor Speed Data

	LR	Pull-Up	BD	Rated	Idle
Speed (RPM)	0	900	1690	1775	1800
Current (Amps)	587	518	316	102	32.8
Torque (ft-lb)	375	350	490	222	0.00

Information Block				
HP	75.0			
Sync. RPM	1800			
Frame	365			
Enclosure	DP			
Construction	TDS			
Voltage	200/400 V			
Frequency	60 Hz			
Design	B			
LR Code letter	F			
Service Factor	1.15			
Temp Rise @ FL	55 ° C			
Duty	CONT			
Ambient	40 ° C			
Elevation	1,000 feet			
Rotor/Shaft wk ²	13.8 Lb-Ft ²			
Ref Wdg	T3654176 NONE			
Sound Pressure @ 1M	75 dBA			
VFD Rating	NONE			
Outline Dwg	B-SS509461LN-1500			
Conn. Diag	A-EE7308AA-LN			
Additional Specifications:				
0				
0				
EQUIV CKT (OHMS / PHASE)				
R1	R2	X1	X2	Xm
0.0470	0.0310	0.2770	0.3490	7.0370

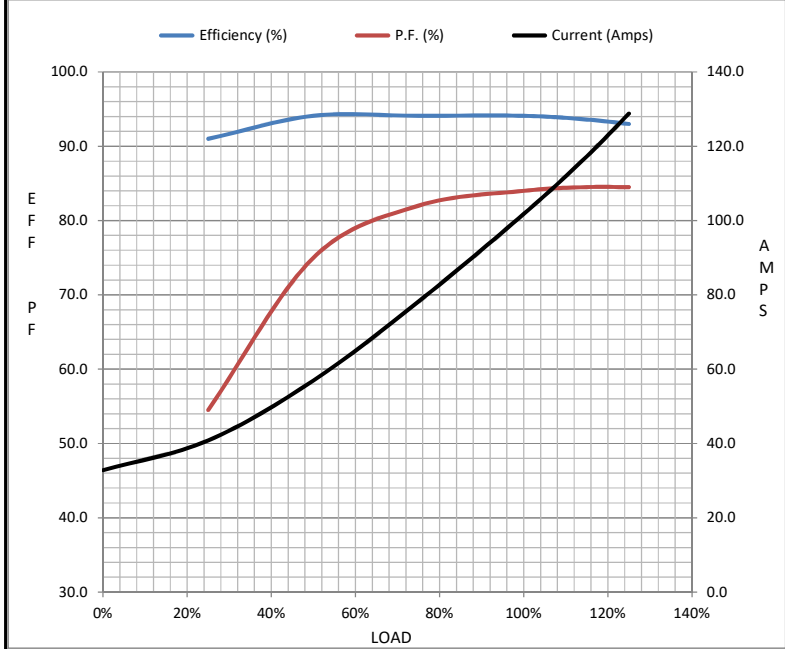

Speed - Torque Curve

