

PRODUCT INFORMATION PACKET



Model No: LM80053
Catalog No: LM80053
3 HP Fire Pump Motor, 3 phase, 1800 RPM, 230/460 V, 182T Frame, TEFC
Fire Pump Motors



Regal and Leeson are trademarks of Regal Rexnord Corporation or one of its affiliated companies.
©2021 Regal Rexnord Corporation, All Rights Reserved. MC017097E





Nameplate Specifications

Output HP	3 Hp	Output KW	2.2 kW
Frequency	60 Hz	Voltage	230/460 V
Current	8.6/4.3 A	Speed	1750 rpm
Service Factor	1.15	Phase	3
Efficiency	87.5 %	Power Factor	74.7
Duty	Continuous	Insulation Class	F
Design Code	B	KVA Code	K
Frame	182T	Enclosure	Totally Enclosed Fan Cooled
Thermal Protection	No	Ambient Temperature	40 °C
Drive End Bearing Size	6206	Opp Drive End Bearing Size	6206
UL	No	CSA	N
CE	Y	IP Code	43
Number of Speeds	1		

Technical Specifications

Electrical Type	Squirrel Cage Induction Run	Starting Method	Across The Line
Poles	4	Rotation	Reversible
Resistance Main	4.8 Ohms	Mounting	Rigid Base
Motor Orientation	Horizontal	Drive End Bearing	Ball
Opp Drive End Bearing	Ball	Frame Material	Cast Iron
Shaft Type	T	Overall Length	15.87 in
Frame Length	8.00 in	Shaft Diameter	1.125 in
Shaft Extension	2.75 in	Assembly/Box Mounting	F1/F2 CAPABLE
Outline Drawing	035662LN-800	Connection Drawing	A-EE7308-LN

This is an uncontrolled document once printed or downloaded and is subject to change without notice. Date Created:10/07/2021

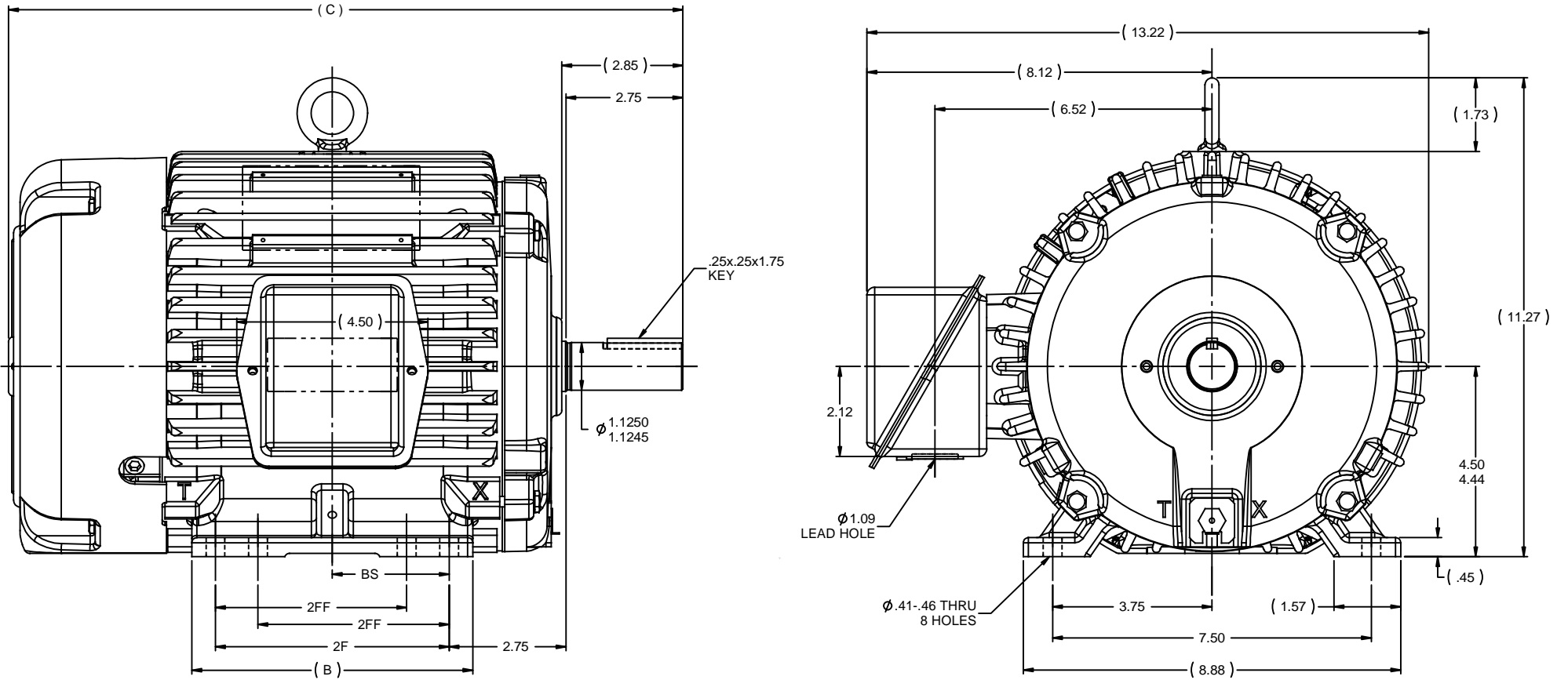

- NOTES:
 1. NAMEPLATE TO BE READ FROM CONDUIT BOX SIDE OF MOTOR.
 2. CONDUIT BOX CAN ROTATED IN 90° STEPS.
 3. CONDUIT BOX CAN BE MOUNTED ON OPPOSITE SIDE BY REMOVING BRACKETS AND TURNING FRAME 180°

800	182/184	15.87	6.61	5.50	4.50	2.75
DASH	FRAME	C	B	2F	2FF	BS

		TOLERANCES UNLESS SPECIFIED			DRAWN SR 05/17/2011	
		DEC	INCHES		CHK SR 05/17/2011	
		.X	±.1	TITLE OUTLINE - TEFC	APPR AK 05/17/2011	
		.XX	±.03	180 FR. - SHEET METAL C'BOX	SCALE 7:16	
		.XXX	±.005	MATL	REF	
		.XXXX	±.0005	FINISH	FMF	
NO	REVISION	BY & DATE	CHK ANG ±7'30"	PREV		
THIS DRAWING IN DESIGN AND DETAIL IS OUR PROPERTY AND MUST NOT BE USED EXCEPT IN CONNECTION WITH OUR WORK. ALL RIGHTS OF DESIGN AND INVENTION ARE RESERVED. THIS IS AN ELECTRONICALLY GENERATED DOCUMENT - DO NOT SCALE THIS PRINT		RFP	CAD FILE 035662LN	SIZE B	DRAWING NO 035662LN	REV 01
		DIST WA - NLV				

THREE PHASE
DUAL VOLTAGE MOTOR

HIGH VOLTAGE



LOW VOLTAGE



VIEW OF TERMINAL END

REF.
WINDING DIAGRAM

T8Y, T2Y, T2BL, T4BX, T2EC, T2G
T6BZ, T2B, T6BL, T4AV, T6B, T4B

OPTIONAL CORD
CONNECTION

L1 — WHITE —
L2 — RED —
L3 — BLACK —

NO.	REVISION	BY & DATE	CHK	TOLERANCES UNLESS SPECIFIED		FINISH	DRAWN	DATE			
				DEC.	INCHES						
				.X	±.1		BLR	06/11/1999			
							ML	06/18/1999			
							GK	06/18/1999			
3	ADDED THE OPTIONAL CORD CONNECTION MU46318	RDH 04/24/2003	DRS	.XX	±.02	TITLE CONNECTION DIAGRAM		SCALE 1=1			
2	RE-ISSUE, ADDED '-' TO PART NUMBER	BLR 08/09/1999	GK	.XXX	±.005	3∅ - DUAL VOLTAGE MOTOR		REF			
1	NEW DRAWING	BLR 06/18/1999	GK	.XXXX	±.0005	MAT'L.		FMF			
				ANG	±7'30"			PREV			
				RFP	CAD FILE EE7308LN			SIZE A	DRAWING NO. EE7308-LN	PAGE OF 3	REV. 3
				DIST WP							





1051 CHEYENNE AVE.
GRAFTON, WI 53024
PH. 262-277-8810

DATA VOLTS: 460

CERTIFICATION DATA SHEET

CONN. DIAGRAM: A-EE7308-LN
OUTLINE: 035662LN-800
WINDING: K1824186

CAT #: LM80053

NONE 1

TYPICAL MOTOR PERFORMANCE DATA

HP	KW	SYNC RPM	FL RPM	FRAME	ENCLOSURE	TYPE	KVA CODE	DESIGN
3	2.2	1800	1750	182T	TEFC	TFS	K	B

PH	HZ	VOLTS	AMPS	START TYPE	DUTY	INSL	S.F.	AMB	ELEV.
3	60	230/460	8.6/4.3	ACROSS THE LINE	CONT	F	1.15	40	3300

F.L. EFF	87.5	3/4 LD EFF	87.8	1/2 LD EFF	85.4	GTD EFF	ELECT. TYPE
F.L. PF	74.7	3/4 LD PF	61.0	1/2 LD PF	51.8	85.5	SQ CAGE IND RUN

F.L. TORQUE	LR AMPS @ 460 V	L.R. TORQUE	B.D. TORQUE	F.L. RISE (° C)
9.0 LB-FT	30.2	21.5 LB-FT 239%	30.3 LB-FT 337%	55

PRESSURE @ 3	SOUND	POWER	ROTOR WK²	MAX. LOAD WK²	SAFE STALL TIME	STARTS/HOUR	MOTOR WGT
62 dBA	71 dBA		0.40 LB-FT²	34 LB-FT²	25 SEC.	2	72 LB.

***** SUPPLEMENTAL INFORMATION *****

DE BRACKET TYPE	ODE BRACKET TYPE	MOUNT TYPE	MOTOR ORIENTATION	SEVERE DUTY	HAZARDOUS LOCATION	DRIP COVER	SCREENS	PAINT
STANDARD	STANDARD	RIGID	HORIZONTAL	NO	NONE	NO	NONE	WATTSAVER

BEARINGS		GREASE	SHAFT TYPE	SPECIAL DE	SPECIAL ODE	SHAFT MATERIAL	FRAME MATERIAL
DE	ODE	POLYREX EM	T	NONE	NONE	1144 STRESSPROOF (C-223)	CAST IRON
BALL	BALL						
6206	6206						

THERMOSTATS	PROTECTORS	WDG RTD's	BRG RTD's	THERMISTORS	CONTROL	SPACE HEATERS
NONE	NOT	NONE	NONE	NONE	FALSE	NA

R1 (ohms/ph)	R2 (ohms/ph)	X1 (ohms/ph)	X2 (ohms/ph)	Xm (ohms/ph)	VIBRATION (in/sec)	FLOAT
0.695	0.466	1.414	1.946	33.597	0.150	ODE

* N O T E S *	INVERTER TORQUE: NONE INV. HP SPEED RANGE: NONE					
	ENCODER: NONE NONE NONE					
	BRAKE: NONE NONE NONE					
	FT-LB: NA VOLTAGE: NONE					
	UL: NONE-INS UL REC					

DATE: 8/31/2018

BRAKE: NONE
NONE

FT-LB: NA
VOLTAGE: NONE

UL: NONE-INS UL REC

Data Sheet

Date: 8/31/2018

LM80053



Data @ **460 V**

Motor Load Data

Load	0%	25%	50%	75%	100%	115%	125%	LR
Current (Amps)	2.00	2.70	3.2	3.7	4.3	4.8	5.1	30.2
Torque (ft-lb)	0.00	2.20	4.4	6.7	9.0	10.4	11.2	21.5
RPM	1800	1788	1777	1763	1750	1,743	1735	0
Efficiency (%)		78.7	85.4	87.8	87.5	85.8	85.7	
P.F. (%)	8.8	33.0	51.8	61.0	74.7	78.4	79.2	57.0

Motor Speed Data

	LR	Pull-Up	BD	Rated	Idle
Speed (RPM)	0	750	1295	1750	1800
Current (Amps)	30.2	30.0	21.1	4.3	2.00
Torque (ft-lb)	21.5	18.5	30.3	9.0	0.00

Information Block				
HP	3.0			
Sync. RPM	1800			
Frame	182			
Enclosure	TEFC			
Construction	TFS			
Voltage	230/460 V			
Frequency	60 Hz			
Design	B			
LR Code letter	K			
Service Factor	1.15			
Temp Rise @ FL	55 ° C			
Duty	CONT			
Ambient	40 ° C			
Elevation	1,000 feet			
Rotor/Shaft wk ²	0.40 Lb-Ft ²			
Ref Wdg	K1824186 NONE			
Sound Pressure @ 1M	62 dBA			
VFD Rating	NONE			
Outline Dwg	035662LN-800			
Conn. Diag	A-EE7308-LN			
Additional Specifications:				
0				
0				
EQUIV CKT (OHMS / PHASE)				
R1	R2	X1	X2	Xm
0.6950	0.4660	1.4140	1.9460	33.5970

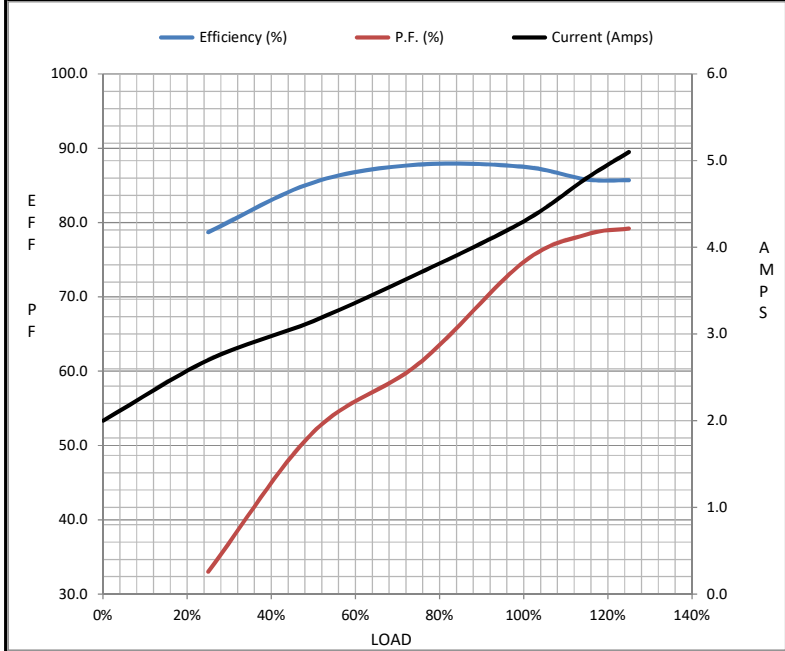

Speed - Torque Curve

