

# PRODUCT INFORMATION PACKET



Model No: LM29671  
Catalog No: LM29671

Elevator Duty Motor, 50 & 40 HP, 3 Ph, 60 & 60 Hz, 200 & 200 V, 3600 & 3600 RPM, 160TZ Frame, OPEN



Regal and Leeson are trademarks of Regal Rexnord Corporation or one of its affiliated companies.  
©2023 Regal Rexnord Corporation, All Rights Reserved. MC017097E





### Nameplate Specifications

Phase	<b>3</b>	Output HP	<b>50 &amp; 40 Hp</b>
Output KW	<b>37.0 &amp; 30.0 kW</b>	Voltage	<b>200 &amp; 200 V</b>
Speed	<b>3515 &amp; 3530 rpm</b>	Service Factor	<b>1.0</b>
Frame	<b>160TZ</b>	Enclosure	<b>Open Enclosed</b>
Thermal Protection	<b>Thermostat</b>	Efficiency	<b>89.5 &amp; 89.5 %</b>
Ambient Temperature	<b>70 °C</b>	Frequency	<b>60 &amp; 60 Hz</b>
Current	<b>133 &amp; 108 A</b>	Power Factor	<b>90.5</b>
Duty	<b>120/80 Starts/Hour</b>	Insulation Class	<b>F</b>
Design Code	<b>B</b>	KVA Code	<b>G</b>
Drive End Bearing Size	<b>6307</b>	Opp Drive End Bearing Size	<b>6307</b>
UL	<b>Recognized</b>	CSA	<b>Y</b>
CE	<b>N</b>	IP Code	<b>10</b>
Number of Speeds	<b>1</b>		

### Technical Specifications

Electrical Type	<b>Squirrel Cage Induction Run</b>	Starting Method	<b>Wye Start Delta Run</b>
Poles	<b>2</b>	Rotation	<b>Reversible</b>
Resistance Main	<b>.312 Ohms</b>	Mounting	<b>Rigid Base</b>
Motor Orientation	<b>Horizontal</b>	Drive End Bearing	<b>Ball</b>
Opp Drive End Bearing	<b>Ball</b>	Frame Material	<b>Rolled Steel</b>
Shaft Type	<b>Single Special Extension</b>	Overall Length	<b>14.53 in</b>
Frame Length	<b>15.35 in</b>	Shaft Diameter	<b>1.250 in</b>
Shaft Extension	<b>2.92 in</b>	Assembly/Box Mounting	<b>F1/F2 CAPABLE</b>
Connection Drawing	<b>A-92652</b>	Outline Drawing	<b>0216000039</b>

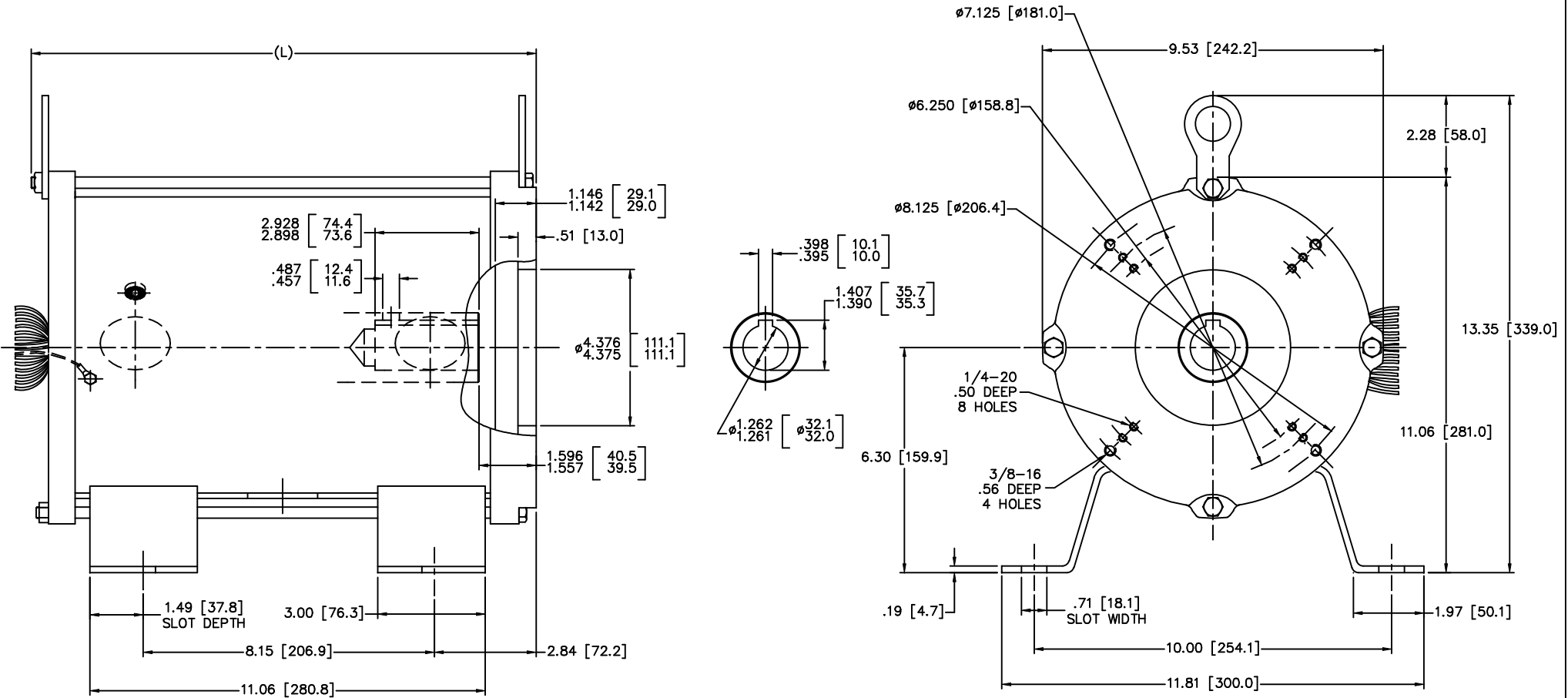

TYPE	HP	L
160ZBS-2	15	14.53 [369.0]
160ZBS-2	20	
160ZBS-2	25	
160ZBS-2	30	
160ZBS-2	40	17.87 [454.0]
160ZBS-2	50	

(MAY NOT BE DRAWN TO SCALE)

		TOLERANCES UNLESS SPECIFIED		Lincoln MOTOR		DRAWN MSG 01-25-2007	
		DEC.	INCHES	CHK	ML 01-25-2007	APPD	GK 01-25-2007
		.X	±.1	TITLE OUTLINE - SUBMERSIBLE ELEVATOR PUMP		SCALE 3-8	
		.XX	±.03	160ZBS FR. - 3 PHASE - DUAL DIMENSIONS		REF	
		.XXX	±.005	MAT'L		FMF HEBEI	
1 UPDATED TO CURRENT STANDARDS		DRS	±.0005	FINISH		PREV	
NO.	REVISION	BY & DATE	CHK	ANG	±7'30"	CAD FILE 0216000039	
THIS DRAWING IN DESIGN AND DETAIL IS OUR PROPERTY AND MUST NOT BE USED EXCEPT IN CONNECTION WITH OUR WORK ALL RIGHTS OF DESIGN AND INVENTION ARE RESERVED THIS IS AN ELECTRONICALLY GENERATED DOCUMENT - DO NOT SCALE THIS PRINT						RFP	
						DIST	
						SIZE	DRAWING NO. PAGE OF REV.
						B	0216000039 1

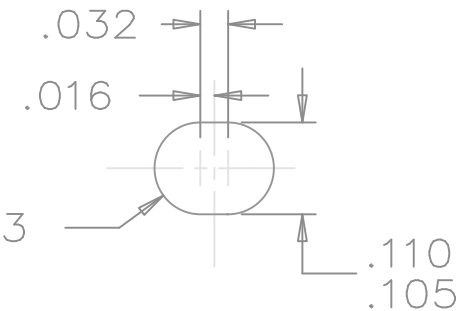
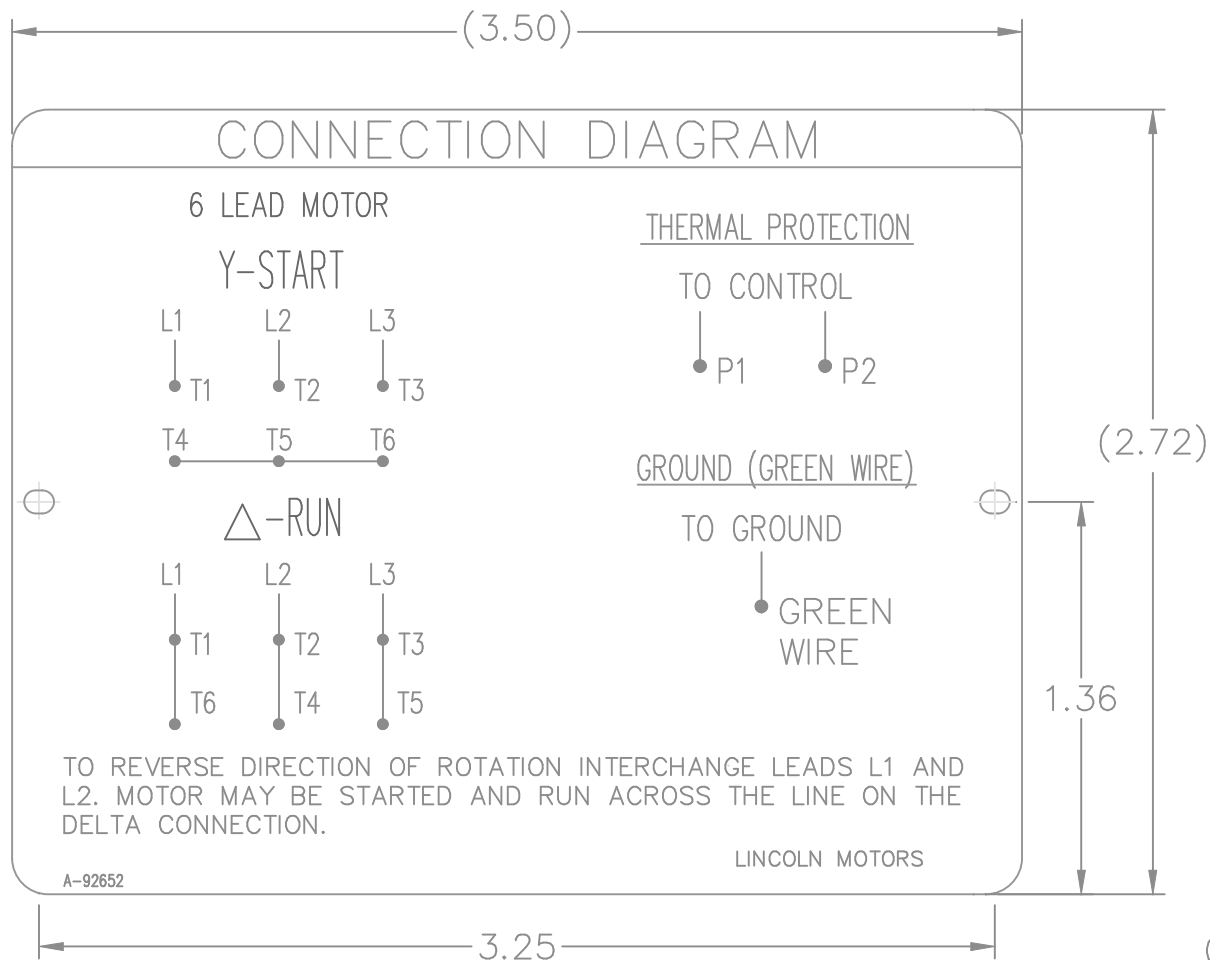

NOTES:

1. MATERIAL 304 STAINLESS STEEL
2. LETTERING AND ARTWORK BLACK
3. ALL DATA MUST BE HYDRAULIC OIL RESISTANT.

				TOLERANCES UNLESS SPECIFIED			DRAWN CTO 02-18-2004						
				DEC.	INCHES		CHK	ML 02-18-2004					
				.X	±.1		APPD	MS 02-18-2004					
				.XX	±.02		SCALE	1.5=1					
				.XXX	±.005		REF						
				.XXX	±.005	TITLE	CONNECTION DIAGRAM PLATE						
				.XXXX	±.0005	MAT'L.	304 STAINLESS STEEL						
NO.	REVISION	BY & DATE	CHK	ANG	±7'30"	FINISH	PREV						
THIS DRAWING IN DESIGN AND DETAIL IS OUR PROPERTY AND MUST NOT BE USED EXCEPT IN CONNECTION WITH OUR WORK ALL RIGHTS OF DESIGN AND INVENTION ARE RESERVED THIS IS AN ELECTRONICALLY GENERATED DOCUMENT - DO NOT SCALE THIS PRINT				RFP	02-18-2004	CAD FILE	92652		SIZE	DRAWING NO.	PAGE	OF	REV.
				DIST	WA	A	92652						

P.O. BOX 8003  
 WAUSAU, WI 54401-8003  
 PH. 715-675-3311



DATA VOLTS: 460

**CERTIFICATION DATA SHEET**

CONN. DIAGRAM: A-92652  
 OUTLINE: 0216000039  
 WINDING: 2152209

CAT #: LM29671

NONE 3

**TYPICAL MOTOR PERFORMANCE DATA**

HP	KW	SYNC RPM	FL RPM	FRAME	ENCLOSURE	TYPE	KVA CODE	DESIGN
50	37	3600	3510	160M	OPEN	TDR	H	B

PH	HZ	VOLTS	AMPS	START TYPE	DUTY	INSL	S.F.	AMB	ELEV.
3	60	200	133	VYE START DELTA RU	30 MIN	F	1.15	70	3300

F.L. EFF	89.5	3/4 LD EFF	91.0	1/2 LD EFF	91.7	GTD EFF	81.5	ELECT. TYPE	SQ CAGE IND RUN
F.L. PF	90.0	3/4 LD PF	88.0	1/2 LD PF	82.5				

F.L. TORQUE	LR AMPS @ 460 V	L.R. TORQUE	B.D. TORQUE	F.L. RISE (°C)
75.0 LB-FT	633	200 LB-FT 267%	150 LB-FT 200%	0

PRESSURE @ 3	POWER	ROTOR WK²	MAX. LOAD WK²	SAFE STALL TIME	STARTS/HOUR	MOTOR WGT
999 dBA	1008 dBA	0.00 LB-FT²	0 LB-FT²	0 SEC.	80	0 LB.

\*\*\* SUPPLEMENTAL INFORMATION \*\*\*

DE BRACKET TYPE	ODE BRACKET TYPE	MOUNT TYPE	MOTOR ORIENTATION	SEVERE DUTY	HAZARDOUS LOCATION	DRIP COVER	SCREENS	PAINT
STANDARD	STANDARD	RIGID	HORIZONTAL	NO	NONE	NO	NONE	GRAY - LINCOLN

BEARINGS		GREASE	SHAFT TYPE	SPECIAL DE	SPECIAL ODE	SHAFT MATERIAL	FRAME MATERIAL
DE	ODE						
BALL	BALL	POLYREX EM	SGL SPL EXT	ELEVATOR MOTOR SH	NONE	AISI 1045 (C-240)	ROLLED STEEL
NONE	NONE						

THERMOSTATS	PROTECTORS	WDG RTD's	BRG RTD's	THERMISTORS	CONTROL	SPACE HEATERS
TSTATS (N/C)	NOT	NONE	NONE	NONE	FALSE	NA

R1 (ohms/ph)	R2 (ohms/ph)	X1 (ohms/ph)	X2 (ohms/ph)	Xm (ohms/ph)	VIBRATION (in/sec)	FLOAT
0	0	0	0	0	0.150	ODE

* N O T E S *	INVERTER TORQUE: NONE	
	INV. HP SPEED RANGE: NONE	
	ENCODER: NONE	
	NONE	
	NONE NONE PPR	

DATE: 1/24/2018	BRAKE: NONE	
	NONE NONE NONE	
	FT-LB: NA	HZ:
	VOLTAGE: NONE	
UL: V-INS, CONST UL REC		

Data Sheet

Date: 1/24/2018

LM29671



Data @ 200 V

Motor Load Data

Load	0%	25%	50%	75%	100%	115%	125%	LR
Current (Amps)	35.7	47.2	71.3	101	133	156	170	633
Torque (ft-lb)	0.00	18.5	37.0	56.0	75.0	87.0	95.0	200
RPM	3600	3580	3560	3535	3510	3,490	3480	0
Efficiency (%)		89.5	91.7	91.0	89.5	87.5	87.5	
P.F. (%)	7.0	63.5	82.5	88.0	90.0	90.0	90.5	76.0

Motor Speed Data

	LR	Pull-Up	BD	Rated	Idle
Speed (RPM)	0	1800	3312	3510	3600
Current (Amps)	633	863	978	133	35.7
Torque (ft-lb)	200	135	150	75.0	0.00

Information Block				
HP	50.0			
Sync. RPM	3600			
Frame	160			
Enclosure	OPEN			
Construction	TDR			
Voltage	200 V			
Frequency	60 Hz			
Design	B			
LR Code letter	H			
Service Factor	1.15			
Temp Rise @ FL	0 °C			
Duty	30 MIN			
Ambient	40 °C			
Elevation	1,000 feet			
Rotor/Shaft wk <sup>2</sup>	0.00 Lb-Ft <sup>2</sup>			
Ref Wdg	2152209 NONE			
Sound Pressure @ 1M	999 dBA			
VFD Rating	NONE			
Outline Dwg	0216000039			
Conn. Diag	A-92652			
Additional Specifications:				
0				
0				
EQUIV CKT (OHMS / PHASE)				
R1	R2	X1	X2	Xm
0.0000	0.0000	0.0000	0.0000	0.0000

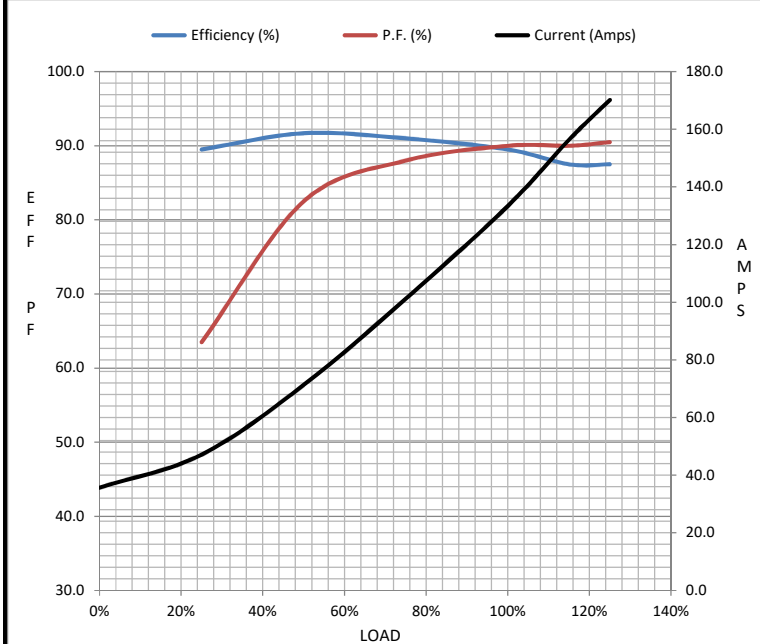

Speed - Torque Curve

