

PRODUCT INFORMATION PACKET



Model No: LM29662
Catalog No: LM29662

Elevator Duty Motor, 25 & 20 HP, 3 Ph, 60 & 60 Hz, 200 & 200 V, 3600 & 3600 RPM, 160TZ Frame, OPEN



Regal and Leeson are trademarks of Regal Rexnord Corporation or one of its affiliated companies.
©2023 Regal Rexnord Corporation, All Rights Reserved. MC017097E





Nameplate Specifications

Phase	3	Output HP	25 & 20 Hp
Output KW	18.7 & 14.9 kW	Voltage	200 & 200 V
Speed	3505 & 3530 rpm	Service Factor	1.0
Frame	160TZ	Enclosure	Open Enclosed
Thermal Protection	Thermostat	Efficiency	86.5 & 86.5 %
Ambient Temperature	70 °C	Frequency	60 & 60 Hz
Current	72.5 & 59 A	Power Factor	86
Duty	120/80 Starts/Hour	Insulation Class	F
Design Code	B	KVA Code	G
Drive End Bearing Size	6307	Opp Drive End Bearing Size	6307
UL	Recognized	CSA	Y
CE	N	IP Code	10
Number of Speeds	1		

Technical Specifications

Electrical Type	Squirrel Cage Induction Run	Starting Method	Wye Start Delta Run
Poles	2	Rotation	Reversible
Resistance Main	.647 Ohms	Mounting	Rigid Base
Motor Orientation	Horizontal	Drive End Bearing	Ball
Opp Drive End Bearing	Ball	Frame Material	Rolled Steel
Shaft Type	Single Special Extension	Overall Length	14.53 in
Frame Length	12.00 in	Shaft Diameter	1.250 in
Shaft Extension	2.92 in	Assembly/Box Mounting	F1/F2 CAPABLE
Outline Drawing	0216000039	Connection Drawing	A-92652

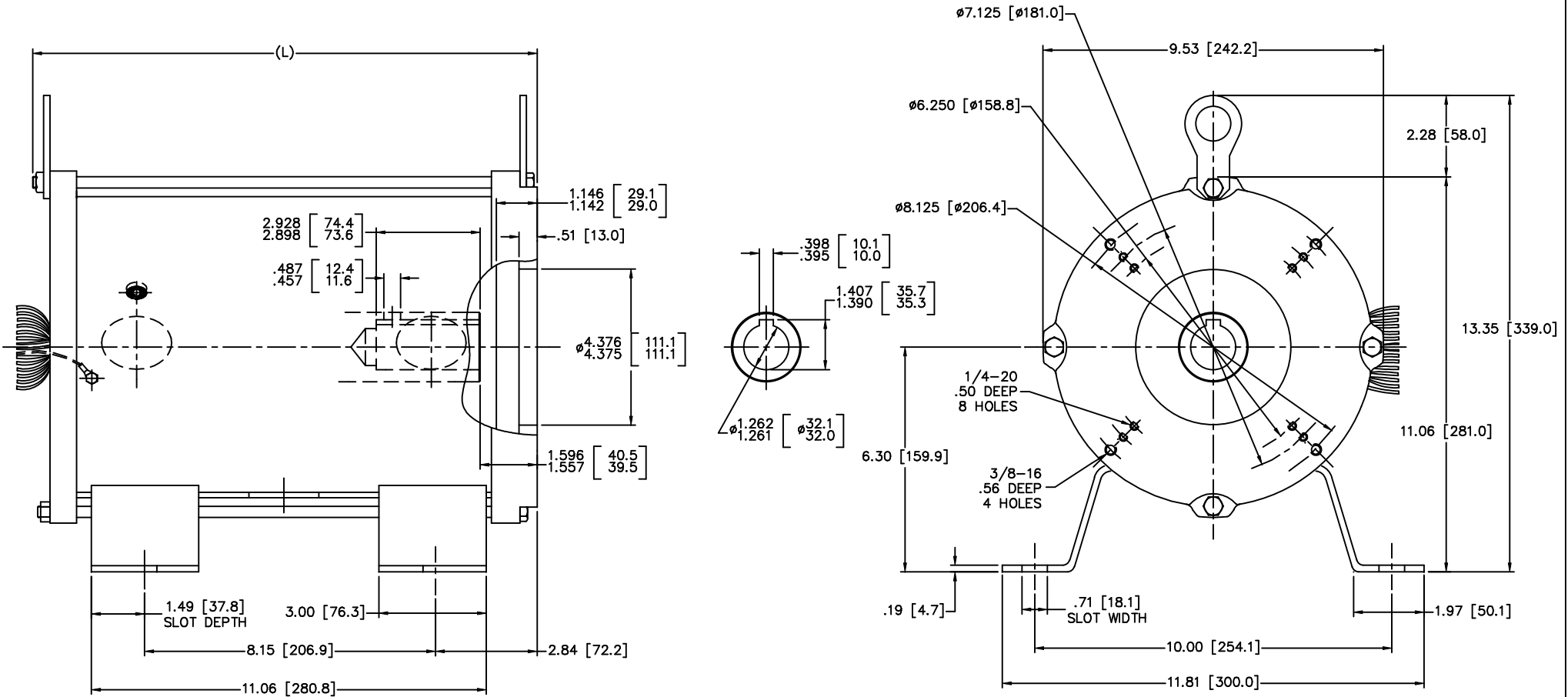

TYPE	HP	L
160ZBS-2	15	14.53 [369.0]
160ZBS-2	20	
160ZBS-2	25	
160ZBS-2	30	
160ZBS-2	40	17.87 [454.0]
160ZBS-2	50	

(MAY NOT BE DRAWN TO SCALE)

		TOLERANCES UNLESS SPECIFIED		Lincoln MOTOR		DRAWN MSG 01-25-2007	
		DEC.	INCHES	CHK	ML 01-25-2007	APPD GK 01-25-2007	
		.X	±.1	TITLE OUTLINE - SUBMERSIBLE ELEVATOR PUMP		SCALE 3-8	
		.XX	±.03	160ZBS FR. - 3 PHASE - DUAL DIMENSIONS		REF	
		.XXX	±.005	MAT'L		FMF HEBEI	
1 UPDATED TO CURRENT STANDARDS		DRS	±.0005	PREV			
NO.	REVISION	BY & DATE	CHK	ANG	FINISH	SIZE	DRAWING NO. PAGE OF REV.
			RFP	±7'30"		B	0216000039 1
THIS DRAWING IN DESIGN AND DETAIL IS OUR PROPERTY AND MUST NOT BE USED EXCEPT IN CONNECTION WITH OUR WORK ALL RIGHTS OF DESIGN AND INVENTION ARE RESERVED THIS IS AN ELECTRONICALLY GENERATED DOCUMENT - DO NOT SCALE THIS PRINT						CAD FILE 0216000039	
						DIST	

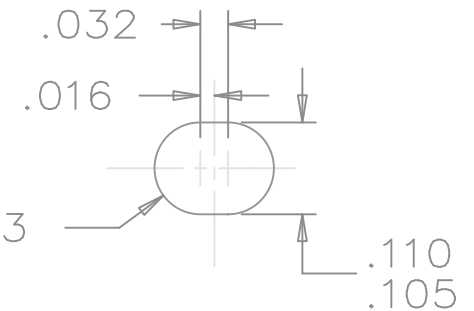
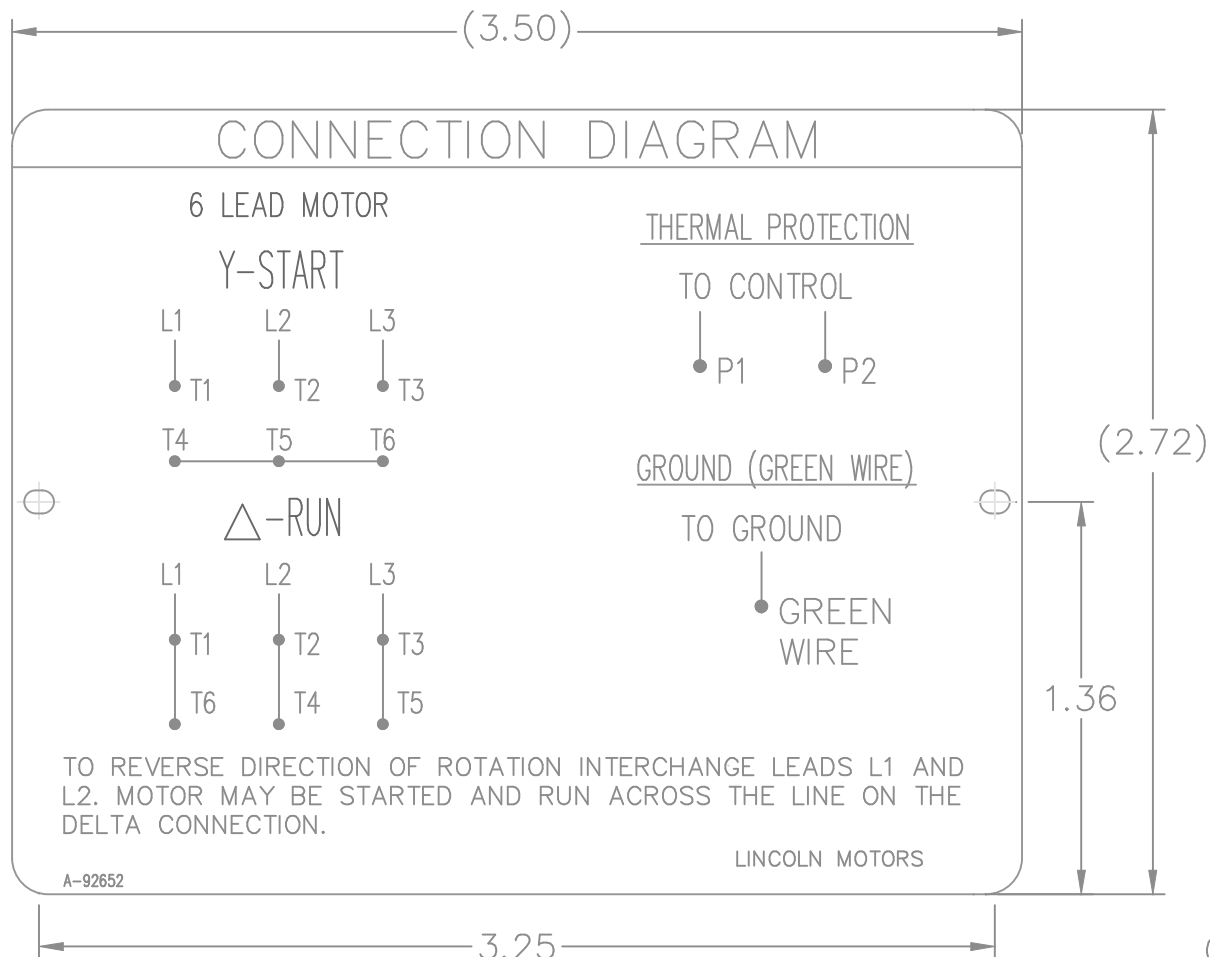

NOTES:

1. MATERIAL 304 STAINLESS STEEL
2. LETTERING AND ARTWORK BLACK
3. ALL DATA MUST BE HYDRAULIC OIL RESISTANT.

				TOLERANCES UNLESS SPECIFIED			DRAWN CTO 02-18-2004						
				DEC.	INCHES		CHK	ML 02-18-2004					
				.X	±.1		APPD	MS 02-18-2004					
				.XX	±.02		SCALE	1.5=1					
				.XXX	±.005		REF						
				.XXX	±.005	TITLE	CONNECTION DIAGRAM PLATE						
				.XXXX	±.0005	MAT'L.	304 STAINLESS STEEL						
NO.	REVISION	BY & DATE	CHK	ANG	±7'30"	FINISH	PREV						
THIS DRAWING IN DESIGN AND DETAIL IS OUR PROPERTY AND MUST NOT BE USED EXCEPT IN CONNECTION WITH OUR WORK ALL RIGHTS OF DESIGN AND INVENTION ARE RESERVED THIS IS AN ELECTRONICALLY GENERATED DOCUMENT - DO NOT SCALE THIS PRINT				RFP	02-18-2004	CAD FILE	92652		SIZE	DRAWING NO.	PAGE	OF	REV.
				DIST	WA	A	92652						

P.O. BOX 8003
 WAUSAU, WI 54401-8003
 PH. 715-675-3311



DATA VOLTS: 460

CERTIFICATION DATA SHEET

CONN. DIAGRAM: A-92652
 OUTLINE: 0216000039
 WINDING: 2152206

CAT #: LM29662

NONE 3

TYPICAL MOTOR PERFORMANCE DATA

HP	KW	SYNC RPM	FL RPM	FRAME	ENCLOSURE	TYPE	KVA CODE	DESIGN
25	18.7	3600	3515	160M	OPEN	TDR	G	B

PH	HZ	VOLTS	AMPS	START TYPE	DUTY	INSL	S.F.	AMB	ELEV.
3	60	200	72.5	VYE START DELTA RU	30 MIN	F	1.15	70	3300

F.L. EFF	88.5	3/4 LD EFF	89.5	1/2 LD EFF	88.5	GTD EFF	77.0	ELECT. TYPE	SQ CAGE IND RUN
F.L. PF	83.5	3/4 LD PF	77.5	1/2 LD PF	65.0				

F.L. TORQUE	LR AMPS @ 460 V	L.R. TORQUE	B.D. TORQUE	F.L. RISE (°C)
37.5 LB-FT	518	60.0 LB-FT 160%	100 LB-FT 267%	0

PRESSURE @ 3	POWER	ROTOR WK²	MAX. LOAD WK²	SAFE STALL TIME	STARTS/HOUR	MOTOR WGT
999 dBA	1008 dBA	0.00 LB-FT²	0 LB-FT²	0 SEC.	80	0 LB.

*** SUPPLEMENTAL INFORMATION ***

DE BRACKET TYPE	ODE BRACKET TYPE	MOUNT TYPE	MOTOR ORIENTATION	SEVERE DUTY	HAZARDOUS LOCATION	DRIP COVER	SCREENS	PAINT
STANDARD	STANDARD	RIGID	HORIZONTAL	NO	NONE	NO	NONE	GRAY - LINCOLN

BEARINGS		GREASE	SHAFT TYPE	SPECIAL DE	SPECIAL ODE	SHAFT MATERIAL	FRAME MATERIAL
DE	ODE						
BALL	BALL	POLYREX EM	SGL SPL EXT	ELEVATOR MOTOR SH	NONE	AISI 1045 (C-240)	ROLLED STEEL
NONE	NONE						

THERMOSTATS	PROTECTORS	WDG RTD's	BRG RTD's	THERMISTORS	CONTROL	SPACE HEATERS
TSTATS (N/C)	NOT	NONE	NONE	NONE	FALSE	NA

R1 (ohms/ph)	R2 (ohms/ph)	X1 (ohms/ph)	X2 (ohms/ph)	Xm (ohms/ph)	VIBRATION (in/sec)	FLOAT
0	0	0	0	0	0.150	ODE

* N O T E S *	INVERTER TORQUE: NONE	
	INV. HP SPEED RANGE: NONE	
	ENCODER: NONE	
	NONE	
	NONE NONE PPR	

DATE: 1/24/2018	BRAKE: NONE	
	NONE NONE NONE	
	FT-LB: NA	HZ:
UL: V-INS, CONST UL REC		

Data Sheet

Date: 1/24/2018

LM29662



Data @ **200 V**

Motor Load Data

Load	0%	25%	50%	75%	100%	115%	125%	LR
Current (Amps)	35.7	39.1	47.2	58.7	72.5	82.8	89.7	518
Torque (ft-lb)	0.00	9.0	18.5	28.0	37.5	43.0	47.0	60.0
RPM	3600	3580	3560	3535	3515	3,500	3485	0
Efficiency (%)		83.5	88.5	89.5	88.5	87.5	85.5	
P.F. (%)	7.0	41.5	65.0	77.5	83.5	85.5	86.0	48.0

Motor Speed Data

	LR	Pull-Up	BD	Rated	Idle
Speed (RPM)	0	1800	3000	3515	3600
Current (Amps)	518	460	345	72.5	35.7
Torque (ft-lb)	60.0	55.0	100	37.5	0.00

Information Block				
HP	25.0			
Sync. RPM	3600			
Frame	160			
Enclosure	OPEN			
Construction	TDR			
Voltage	200 V			
Frequency	60 Hz			
Design	A			
LR Code letter	G			
Service Factor	1.15			
Temp Rise @ FL	0 °C			
Duty	30 MIN			
Ambient	40 °C			
Elevation	1,000 feet			
Rotor/Shaft wk ²	0.00 Lb-Ft ²			
Ref Wdg	2152206 NONE			
Sound Pressure @ 1M	999 dBA			
VFD Rating	NONE			
Outline Dwg	0216000039			
Conn. Diag	A-92652			
Additional Specifications:				
0				
0				
EQUIV CKT (OHMS / PHASE)				
R1	R2	X1	X2	Xm
0.0000	0.0000	0.0000	0.0000	0.0000

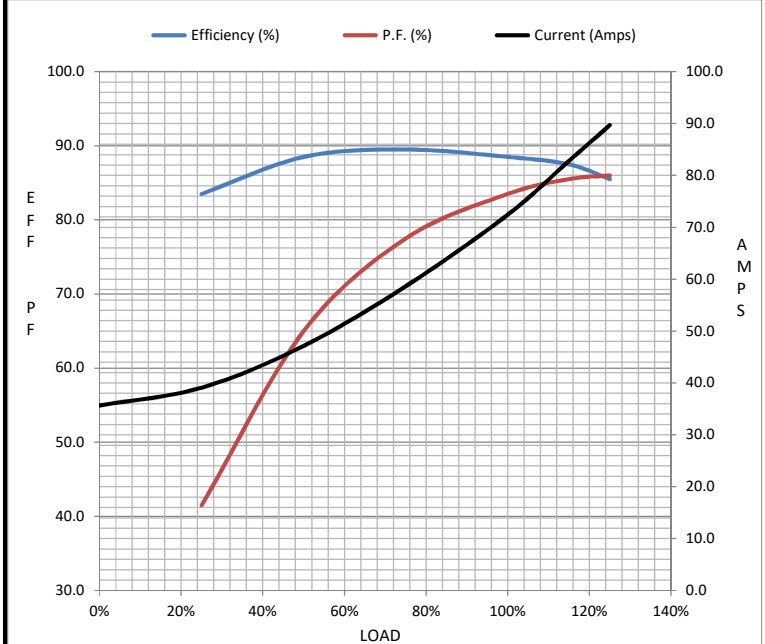

Speed - Torque Curve

