

# PRODUCT INFORMATION PACKET

Model No: LM28150

Catalog No: LM28150

Elevator Duty Motor, 40 HP, 3 Ph, 60 Hz, 200 V, 1200 RPM, 364T Frame, DP



Regal and are trademarks of Regal Rexnord Corporation or one of its affiliated companies.  
©2022 Regal Rexnord Corporation, All Rights Reserved. MC017097E

### Nameplate Specifications

Output HP	<b>40 Hp</b>	Output KW	<b>30.0 kW</b>
Frequency	<b>60 Hz</b>	Voltage	<b>200 V</b>
Current	<b>113.0 A</b>	Speed	<b>1187 rpm</b>
Service Factor	<b>1</b>	Phase	<b>3</b>
Efficiency	<b>93 %</b>	Power Factor	<b>82</b>
Duty	<b>Elevator</b>	Insulation Class	<b>F</b>
Design Code	<b>INV</b>	KVA Code	<b>J</b>
Frame	<b>364T</b>	Enclosure	<b>Drip Proof</b>
Thermal Protection	<b>No Protection</b>	Ambient Temperature	<b>40 °C</b>
Drive End Bearing Size	<b>313</b>	Opp Drive End Bearing Size	<b>311</b>
UL	<b>Recognized</b>	CSA	<b>Y</b>
CE	<b>Y</b>	IP Code	<b>22</b>
Number of Speeds	<b>1</b>		

### Technical Specifications

Electrical Type	<b>Squirrel Cage Inverter Duty</b>	Starting Method	<b>Wye Start Delta Run Or Inverter</b>
Poles	<b>6</b>	Rotation	<b>Reversible</b>
Resistance Main	<b>.121 Ohms</b>	Mounting	<b>Rigid Base</b>
Motor Orientation	<b>Horizontal</b>	Drive End Bearing	<b>Ball</b>
Opp Drive End Bearing	<b>Ball</b>	Frame Material	<b>Rolled Steel</b>
Shaft Type	<b>T</b>	Overall Length	<b>31.56 in</b>
Frame Length	<b>15.48 in</b>	Shaft Diameter	<b>2.375 in</b>
Shaft Extension	<b>5.88 in</b>	Assembly/Box Mounting	<b>F1/F2 CAPABLE</b>
Inverter Load	<b>CONSTANT 1000:1</b>		
Connection Drawing	<b>A-EE7340D-LN</b>	Outline Drawing	<b>XH2D1ES33B-1548</b>

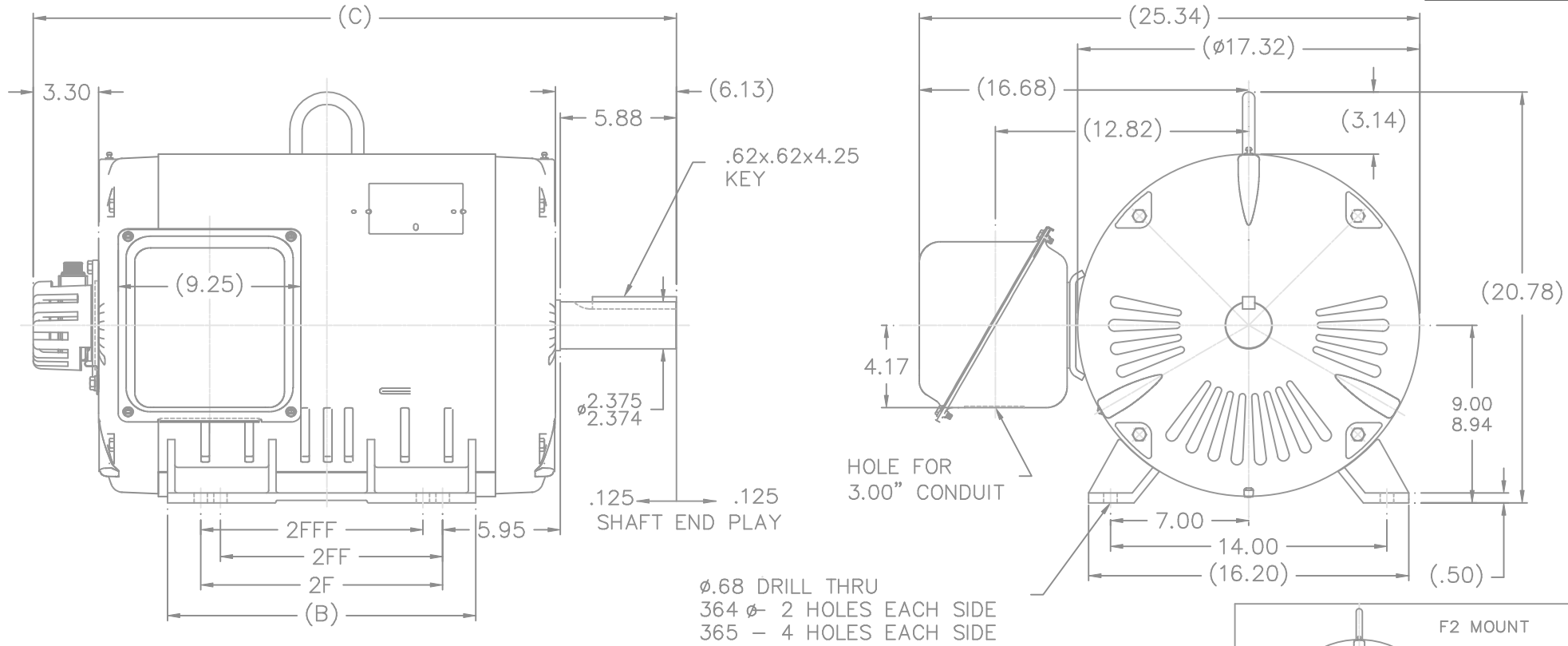

\*VVVF ELEVATOR HOIST MOTOR WITH SHAFT ENDPLAY\*

NOTES:  
1. NAMEPLATES TO BE READ FROM CONDUIT BOX SIDE OF MOTOR.

DASH	FRAME	C	B	2F	2FF	2FFF	BS
1548	364T	31.56	14.61	11.25			11.07
1648	365T	32.56	15.61	12.25	11.25	11.25	12.07

				TOLERANCES UNLESS SPECIFIED		Lincoln MOTORS		DRAWN RDH 11/27/2002	
				DEC.	INCHES			CHK	ML 11/27/2002
				.X	±.1			APPD	HNH 12/02/2002
				.XX	±.03	TITLE OUTLINE VVVF ELEVATOR HOIST MOTOR WITH SPL ENDPLAY 360T ODP UE		SCALE	1=5
				.XXX	±.005			REF	
				.XXXX	±.0005			FMF	
				CHK	ANG ±7'30"			PREV	
1 NEW DRAWING MU43936 RDH 12/02/2002				HNH	.XXXX ±.0005	MAT'L			
NO. REVISION BY & DATE				CHK	ANG ±7'30"	FINISH			
THIS DRAWING IN DESIGN AND DETAIL IS OUR PROPERTY AND MUST NOT BE USED EXCEPT IN CONNECTION WITH OUR WORK ALL RIGHTS OF DESIGN AND INVENTION ARE RESERVED THIS IS AN ELECTRONICALLY GENERATED DOCUMENT - DO NOT SCALE THIS PRINT				RFP		CAD FILE XH2D1ES33B		SIZE	DRAWING NO. PAGE OF REV.
				DIST	BY			B	XH2D1ES33B 1

THREE PHASE  
WYE START DELTA RUN

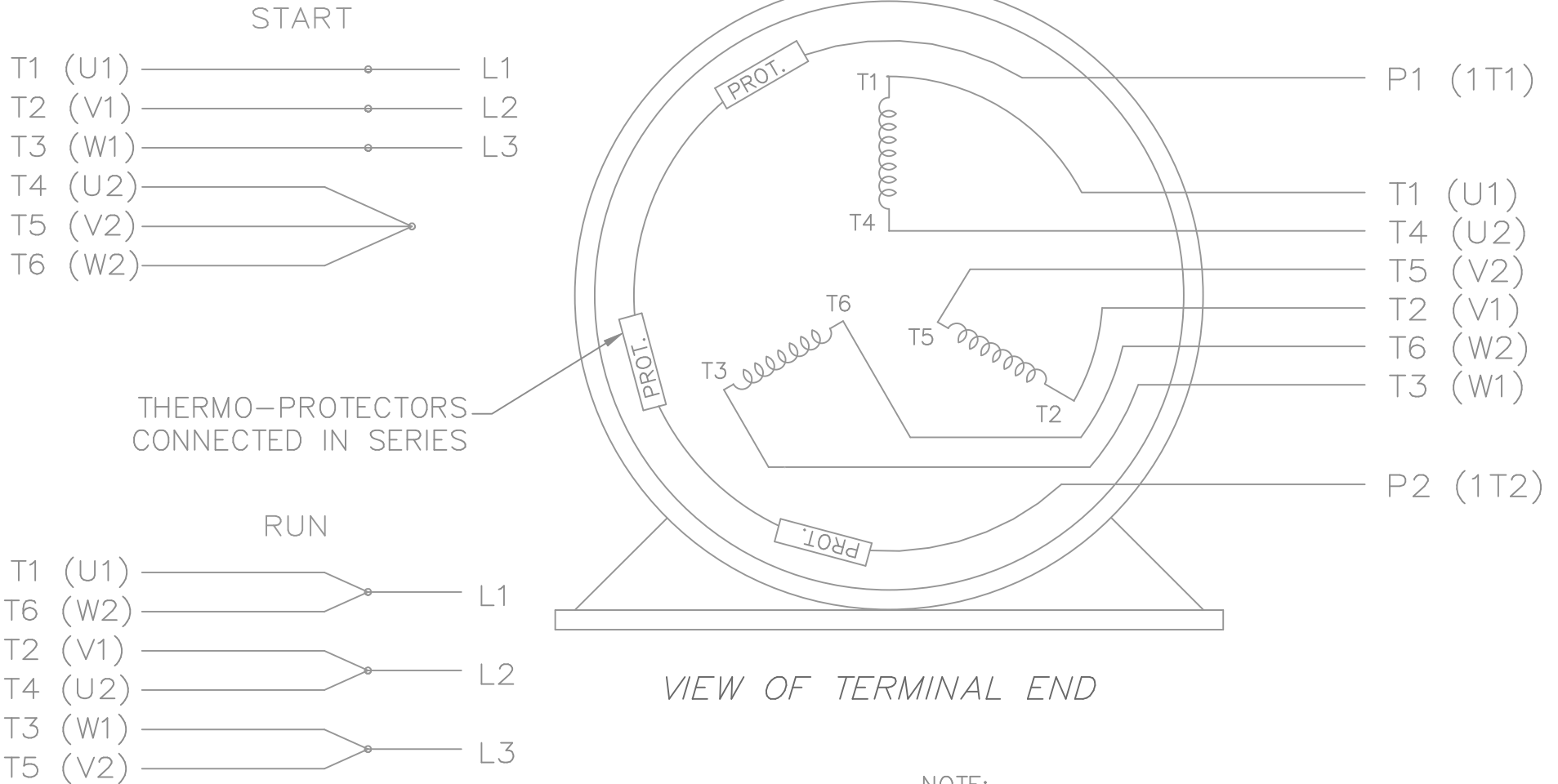

VIEW OF TERMINAL END

NOTE:  
IEC LEAD MARKINGS ARE NOTED IN PARANTHESES

				TOLERANCES UNLESS SPECIFIED			DRAWN KL 11-10-2000				
				DEC.	INCHES		CHK DJK 11-10-2000				
				.X	±.1		APPD DJK 11-10-2000				
				.XX	±.02		SCALE 1=1				
2	ADDED IEC LEAD MARKINGS	MSG 10-08-2008	ML	.XXX	±.005	TITLE CONNECTION DIAGRAM - EXTERNAL - 3φ WYE START DELTA RUN - SINGLE VOLTAGE		REF			
1	NEW DRAWING MU34618	KL 11-10-2000	DJK	.XXXX	±.0005	MAT'L.		FMF			
NO.	REVISION	BY & DATE	CHK	ANG	±7'30"	FINISH		PREV			
THIS DRAWING IN DESIGN AND DETAIL IS OUR PROPERTY AND MUST NOT BE USED EXCEPT IN CONNECTION WITH OUR WORK ALL RIGHTS OF DESIGN AND INVENTION ARE RESERVED THIS IS AN ELECTRONICALLY GENERATED DOCUMENT - DO NOT SCALE THIS PRINT				RFP	11-10-2000	CAD FILE EE7340D_LN		SIZE A	DRAWING NO. EE7340D_LN	PAGE OF 2	REV. 2



**LEESON ELECTRIC CORPORATION**  
 TYPICAL PERFORMANCE CURVE for AC MOTOR

Curve at 200 Volts      HP 40.00      PHASE 3  
60 HZ  
40 HP      VOLTS 200  
    HZ 60      RPM 1187

Model No LM28150

Catalog No LM28150BA

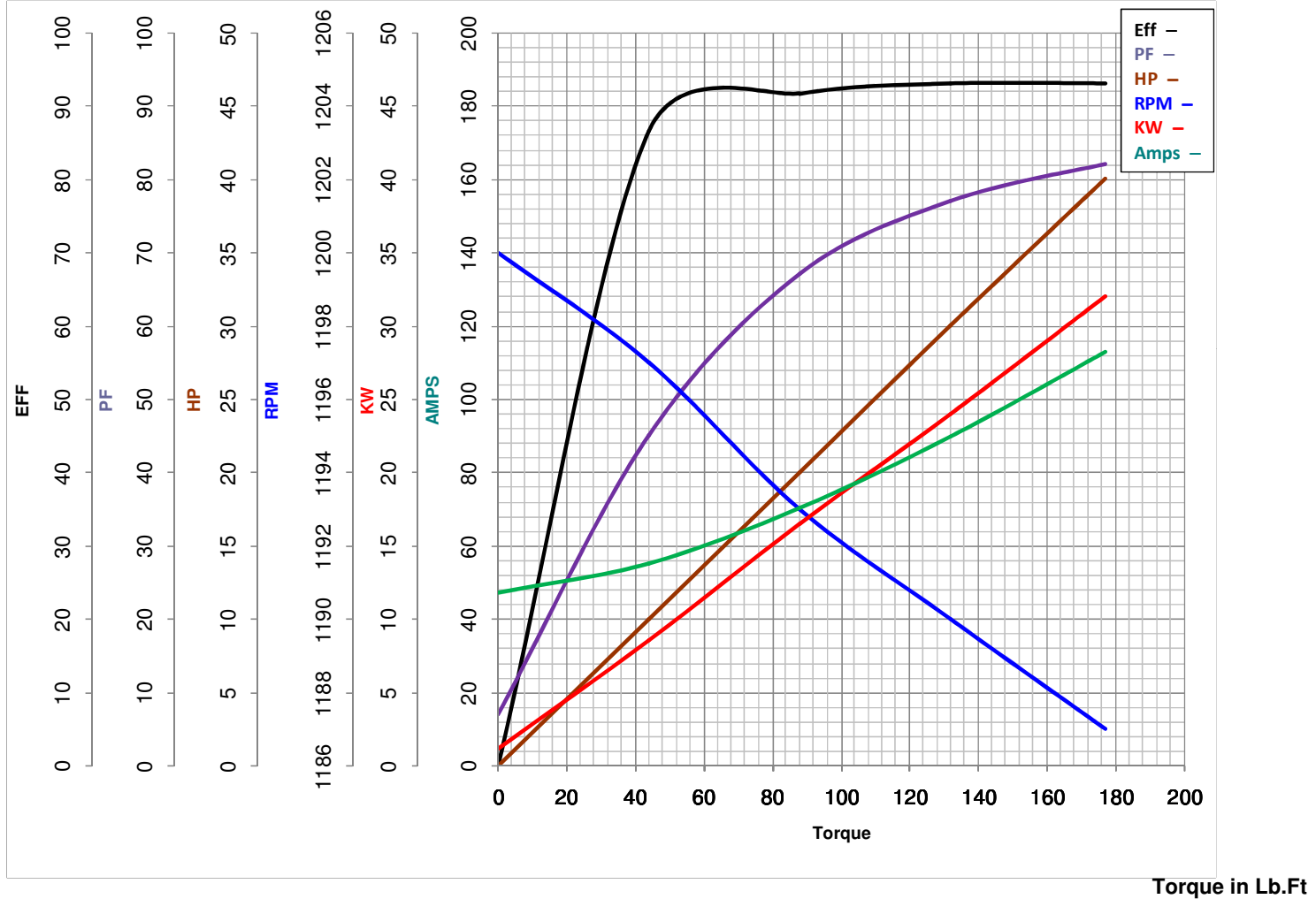

FL TORQUE 177 Lb.Ft  
 BD TORQUE 605.0 Lb.Ft  
 LR TORQUE 380 Lb.Ft

FL AMPS 113  
 PU TORQUE 361.0 Lb.Ft  
 LR AMPS 920

WINDING L3646016-2

Date 6/4/2018