

PRODUCT INFORMATION PACKET

Model No: LM28146

Catalog No: LM28146

Elevator Duty Motor, 30 HP, 3 Ph, 40 Hz, 200 V, 1200 RPM, 326T Frame, DP



Regal and are trademarks of Regal Rexnord Corporation or one of its affiliated companies.
©2022 Regal Rexnord Corporation, All Rights Reserved. MC017097E

Nameplate Specifications

Output HP	30 Hp	Output KW	22.4 kW
Frequency	40 Hz	Voltage	200 V
Current	85.0 A	Speed	1180 rpm
Service Factor	1	Phase	3
Efficiency	91.7 %	Power Factor	82
Duty	Elevator	Insulation Class	F
Design Code	INV	KVA Code	L
Frame	326T	Enclosure	Drip Proof
Thermal Protection	No Protection	Ambient Temperature	40 °C
Drive End Bearing Size	311	Opp Drive End Bearing Size	309
UL	Recognized	CSA	Y
CE	N	IP Code	22
Number of Speeds	1		

Technical Specifications

Electrical Type	Squirrel Cage Inverter Duty	Starting Method	Inverter Only
Poles	4	Rotation	Reversible
Resistance Main	.296 Ohms	Mounting	Rigid Base
Motor Orientation	Horizontal	Drive End Bearing	Ball
Opp Drive End Bearing	Ball	Frame Material	Rolled Steel
Shaft Type	T	Overall Length	30.80 in
Frame Length	17.13 in	Shaft Diameter	2.125 in
Shaft Extension	5.2 in	Assembly/Box Mounting	F1/F2 CAPABLE
Connection Drawing	3A217-8	Outline Drawing	XG2D1ES33B-1657

This is an uncontrolled document once printed or downloaded and is subject to change without notice. Date Created:09/07/2022

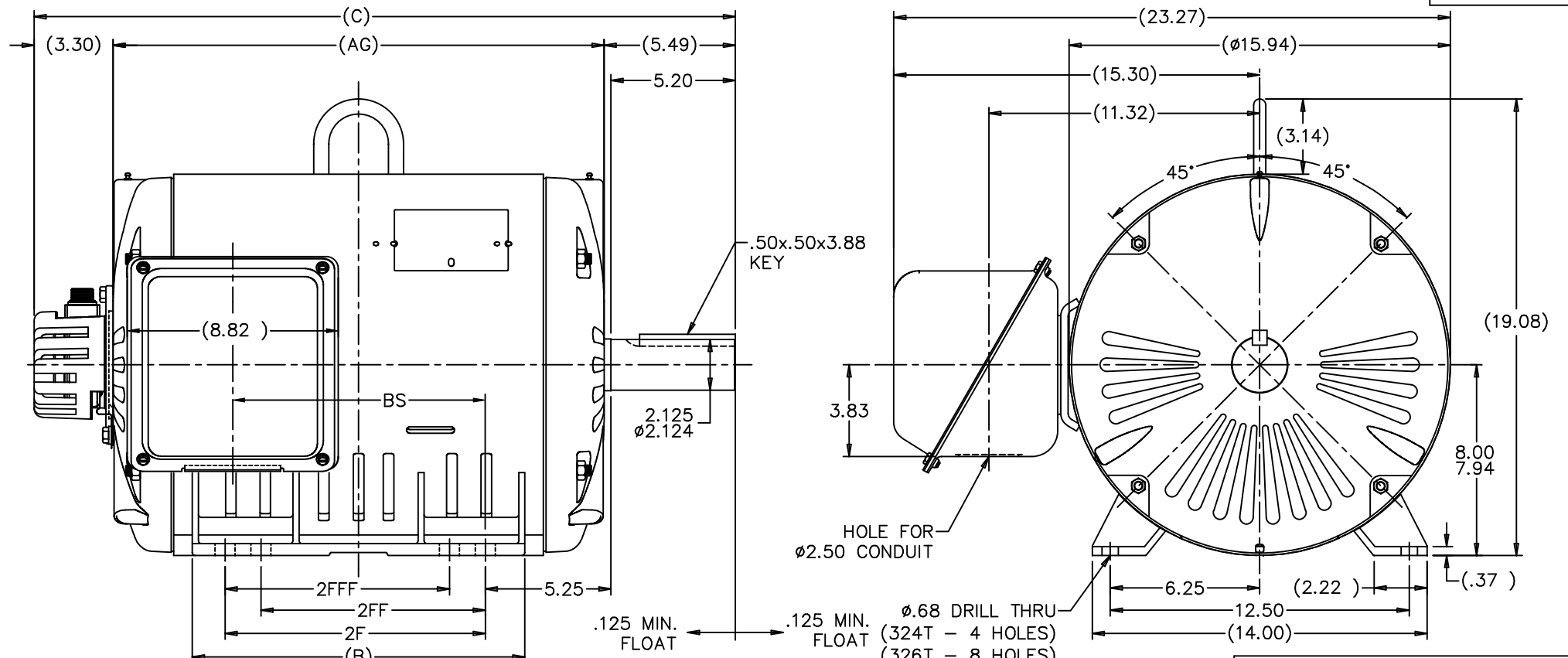

NOTES:
 1. CONDUIT BOX CAN BE ROTATED IN 90° STEPS.
 2. NAMEPLATES TO BE READ FROM CONDUIT BOX SIDE OF MOTOR.

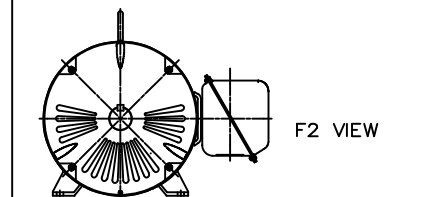

DASH	FRAME	C	AG	B	2F	2FF	2FFF	BS
1507	324T	29.30	20.51	13.52	10.50			10.51
1657	326T	30.80	22.01	15.02	12.00	10.50	10.50	12.01

				TOLERANCES UNLESS SPECIFIED		Lincoln ROTOR		DRAWN CTO 06-10-2002	
				DEC.	INCHES			CHK	ML 06-10-2002
				.X	±.1			APPD	HNH 06-10-2002
				.XX	±.03	TITLE		SCALE 1=4	
				.XXX	±.005	VVVF ELEVATOR HOIST MOTOR 320 ODP UE		REF	
NO.	REVISION	MU41735	CTO 06/10/02	HNH	.XXXX	±.0005	MATL	FMF	
				CHK	ANG	±7'30"	FINISH	PREV	
				RFP	CAD FILE		SIZE	DRAWING NO.	REV.
				DIST	BY	xg2d1es33b	B	XG2D1ES33B	1
THIS DRAWING IN DESIGN AND DETAIL IS OUR PROPERTY AND MUST NOT BE USED EXCEPT IN CONNECTION WITH OUR WORK ALL RIGHTS OF DESIGN AND INVENTION ARE RESERVED THIS IS AN ELECTRONICALLY GENERATED DOCUMENT - DO NOT SCALE THIS PRINT									