

PRODUCT INFORMATION PACKET



Model No: LM17193
Catalog No: LM17193
15 HP Special Voltage Motor, 3 phase, 1800 RPM, 575 V, 254TC Frame, TEFC
575 Volts Motors



Regal and Leeson are trademarks of Regal Beloit Corporation or one of its affiliated companies.
©2021 Regal Beloit Corporation, All Rights Reserved. MC017097E





Nameplate Specifications

Output HP	15 Hp	Output KW	11.2 kW
Frequency	60 Hz	Voltage	575 V
Current	15.1 A	Speed	1775 rpm
Service Factor	1.25	Phase	3
Efficiency	92.4 %	Power Factor	81
Duty	Continuous	Insulation Class	F
Design Code	B	KVA Code	G
Frame	254TC	Enclosure	Totally Enclosed Fan Cooled
Thermal Protection	No	Ambient Temperature	40 °C
Drive End Bearing Size	6309	Opp Drive End Bearing Size	6208
UL	Recognized	CSA	Y
CE	Y	IP Code	43

Technical Specifications

Electrical Type	Squirrel Cage Induction Run	Starting Method	Across The Line
Poles	4	Rotation	Reversible
Resistance Main	.649 Ohms	Mounting	Rigid Base
Motor Orientation	Horizontal	Drive End Bearing	Ball
Opp Drive End Bearing	Ball	Frame Material	Aluminum
Shaft Type	T	Overall Length	24.00 in
Frame Length	12.13 in	Shaft Diameter	1.625 in
Shaft Extension	4 in	Assembly/Box Mounting	F1/F2 CAPABLE
Outline Drawing	SS321103LN-1200	Connection Drawing	EE7300

This is an uncontrolled document once printed or downloaded and is subject to change without notice. Date Created:05/01/2021

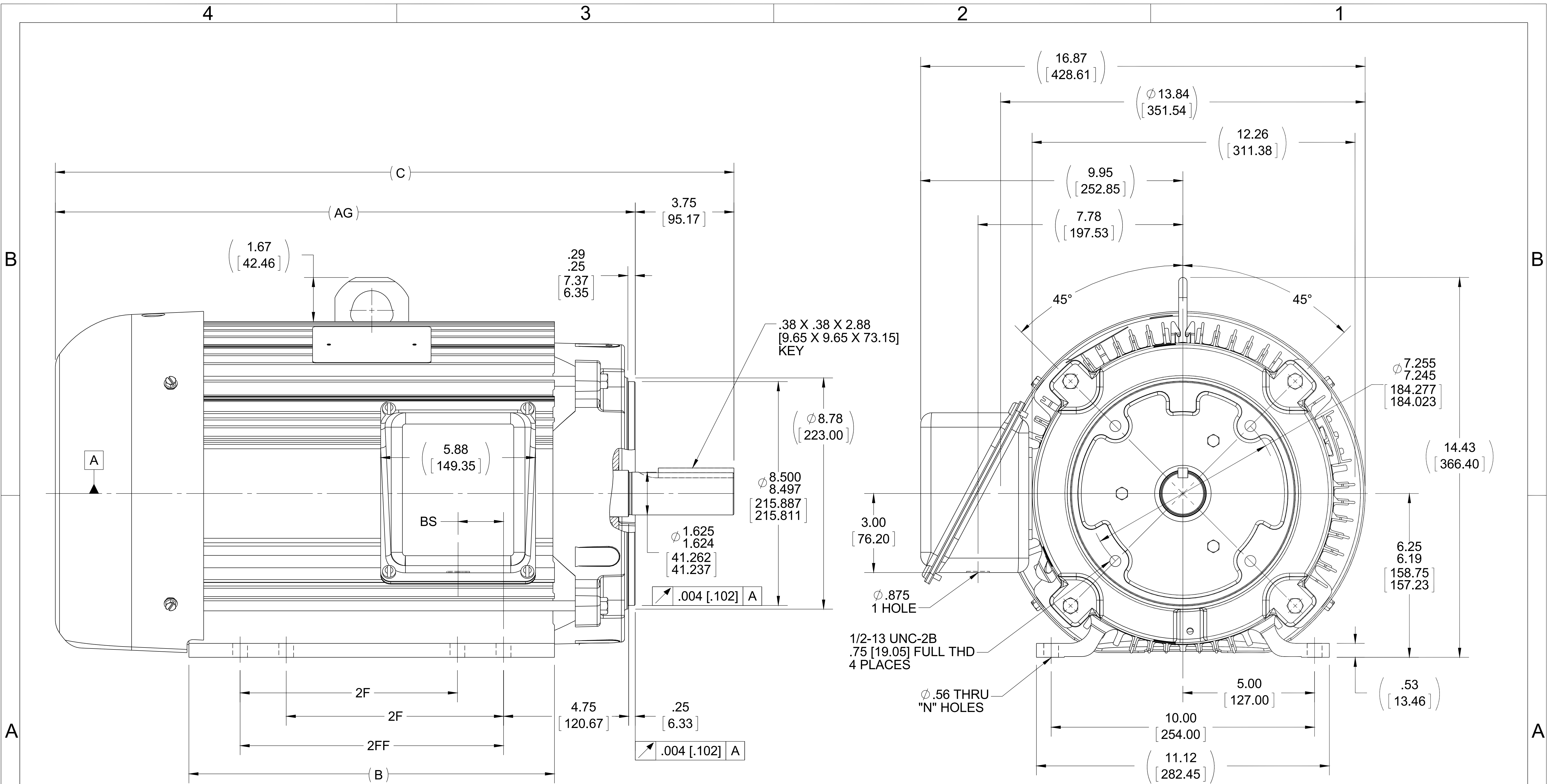

NOTES:
 1. CONDUIT BOX CAN BE ROTATED IN 90° STEPS
 2. NAMEPLATES TO BE READ FROM CONDUIT BOX SIDE OF MOTOR

DASH	FRAME	C	B	BS	2F	2FF	AG	N
1200	254TC	24.00 [609.60]	12.13 [308.10]	1.73 [43.94]	8.25 [209.55]	-----	20.25 [514.35]	4
1375	254/6TC	25.75 [654.05]	13.88 [352.55]	1.73 [43.94]	8.25 [209.55]	10.00 [254.00]	22.00 [558.80]	8

DRAWING REVISION A	REVISION BY W. JOERGER	DATE 12-30-2015
ECO ECO-0087892	APPROVED BY E. HEIL	DATE 12-30-2015
ECO DESCRIPTION RE-DRAWN ON SOLIDWORKS		
<small>COPYRIGHT REGAL BELOIT AMERICA, INC. ALL RIGHTS RESERVED. PROPRIETARY AND CONFIDENTIAL INFORMATION - THIS DOCUMENT IS THE PROPERTY OF REGAL BELOIT AMERICA, INC. ("OWNER") AND CONTAINS OWNER'S PROPRIETARY INFORMATION. ANY PERSON, CORPORATION OR OTHER FIRM RECEIVING IT IS DEEMED, BY RECEIVING IT, TO AGREE THAT IT, AND/OR ANY PART OF IT, SHALL NOT BE DISCLOSED TO ANY PERSON, CORPORATION OR OTHER ENTITY, DUPLICATED, AND/OR USED, EXCEPT AS EXPRESSLY APPROVED IN WRITING IN ADVANCE BY OWNER. THIS DOCUMENT SHALL BE RETURNED TO OWNER UPON REQUEST. IT MAY BE SUBJECT TO CERTAIN RESTRICTIONS UNDER APPLICABLE EXPORT CONTROL LAWS AND REGULATIONS.</small>		

TOLERANCES UNLESS OTHERWISE SPECIFIED:

DEC.	INCH	mm	ANGLE
.X	±0.1	[±2.5]	±7° 30"
.XX	±0.03	[±0.76]	
.XXX	±0.005	[±0.127]	
.XXXX	±0.0005	[±0.0127]	

REMOVE BURRS & BREAK SHARP EDGES: .003/.015 [0.076/.381] X 45°
 CORNER FILLETS: R.02 [51]
 MACHINED SURFACES: 200 INCH 5.1 mm SHOWN IN [BRACKETS]

DRAWN BY CTO
DATE 05-11-2004
APPROVED BY TB
DATE 05-11-2004
REFERENCE
THIRD ANGLE PROJECTION

Regal Beloit America, Inc.	
DESCRIPTION OUTLINE	
250TC FR - ALUM FR - TEFC	
MATERIAL	PROCESS/FINISH
SIZE B	DRAWING NUMBER SS321103LN
	SHEET 1 OF 1

**THREE PHASE - SINGLE VOLTAGE
MOTOR - CONDUIT BOX @ 'A'**

**TO REVERSE ROTATION:
INTERCHANGE ANY TWO
LINE LEAD CONNECTIONS.**

TERMINAL BLOCK WHEN SPECIFIED



VIEW OF TERMINAL END

**IF MOTOR HAS
6 LEADS**



A-9806 DECAL

**OPTIONAL CORD
CONNECTION**

- L1 _____ WHITE _____
- L2 _____ RED _____
- L3 _____ BLACK _____

DRAWING REVISION AB	REVISION BY JJB	DATE 06-27-2017
ECO ECO-0125361	APPROVED BY TB	DATE 06-27-2017
ECO DESCRIPTION UPDATED TO CURRENT STANDARDS		
<small>COPYRIGHT REGAL BELOIT AMERICA, INC. ALL RIGHTS RESERVED. PROPRIETARY AND CONFIDENTIAL INFORMATION - THIS DOCUMENT IS THE PROPERTY OF REGAL BELOIT AMERICA, INC. ("OWNER") AND CONTAINS OWNER'S PROPRIETARY INFORMATION. ANY PERSON, CORPORATION OR OTHER FIRM RECEIVING IT IS DEEMED, BY RECEIVING IT, TO AGREE THAT IT, AND/OR ANY PART OF IT, SHALL NOT BE DISCLOSED TO ANY PERSON, CORPORATION OR OTHER ENTITY, DUPLICATED, AND/OR USED, EXCEPT AS EXPRESSLY APPROVED IN WRITING IN ADVANCE BY OWNER. THIS DOCUMENT SHALL BE RETURNED TO OWNER UPON REQUEST. IT MAY BE SUBJECT TO CERTAIN RESTRICTIONS UNDER APPLICABLE EXPORT CONTROL LAWS AND REGULATIONS.</small>		



DRAWN BY DA
DATE 03-26-1993
APPROVED BY TB
DATE 03-26-1993
REFERENCE
THIRD ANGLE PROJECTION

Regal Beloit America, Inc.		
		DESCRIPTION CONNECTION DIAGRAM EXTERNAL - SINGLE VOLTAGE - 3Ø MOTOR
MATERIAL	PROCESS/FINISH	
SIZE A	DRAWING NUMBER EE7300	SHEET 1 OF 1