

PRODUCT INFORMATION PACKET

marathon®
Motors

Model No: KS9P8020A60W45XSX

Catalog No: AL08D4040MFAFTOAOO

9.8 Kw, Crane Duty Slipring Motors , 3 phase, 8 Pole, 415 V, S5 Duty, KS200L1 Frame, 60 CDF,
300 Start/Hr., TEFC



Regal and Marathon are trademarks of Regal Rexnord Corporation or one of its affiliated companies.

©2023 Regal Rexnord Corporation, All Rights Reserved. MC017097E

RegalRexnord

Nameplate Specifications

Output HP	13.10 Hp	Output KW	9.8 kW
Frequency	50 Hz	Voltage	415 V
Current	26.7 A	Speed	735 rpm
Phase	3	Duty	S5
Frame	KS200L1	Enclosure	Totally Enclosed Fan Cooled
Thermal Protection	No Protection	Ambient Temperature	45 °C
Drive End Bearing Size	6312	Opp Drive End Bearing Size	6312
UL	No	CSA	No
CE	No	IP Code	55
CDF	60 %	Start/Hr	300
RA	23.5 A	RV	255 V
Insulation class Stator/Rotor	F/F	Temp. Rise Stator/Rotor	75/75 K
Stator Connection	Delta	Rotor Connection	Star
Efficiency Class	Standard		

Technical Specifications

Electrical Type	Slipring	Starting Method	Rotor resistance starter
Rotation	Bi-Directional	Mounting	IMB3
Motor Orientation	Horizontal	Drive End Bearing	Antifriction
Opp Drive End Bearing	Antifriction	Frame Material	Cast Iron/Fabricated
Shaft Type	Single Cylinder	Overall Length	947.00 mm
Frame Length	947.00 mm	Shaft Diameter	55.000 mm
Shaft Extension	110 mm	Assembly/Box Mounting	Top
Rotor GD2	2.17 kg·m²	Pull Out Torque	4.2
Outline Drawing	CM1383	Connection Drawing	DP2256

These drawing and design are the property of Marathon Electric Motors (India) Limited. These must not be copied or lent to any other party without the written consent of Marathon Electric Motors (India) Limited.

REV. 09 CM1383 DRAWING No.

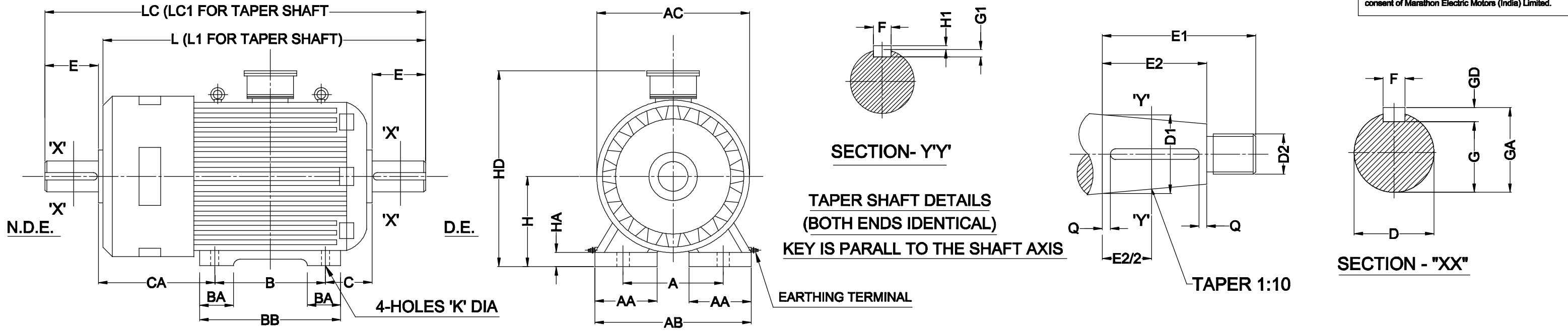

PT. NO.	FRAME	POLE	D(SHAFT DIA)		E	GA	F		GD		G		H		FIXING DIMENSIONS				K	HA	AC	HD	AB	AA	BB	BA	L	LC	L1	LC1	TAPER SHAFT DIMENSIONS DETAILS (BOTH)							
			NOM.	TOL.			NOM.	TOL.	NOM.	TOL.	NOM.	TOL.	NOM.	TOL.	A	B	C	CA													D1	D2	E1	E2	F1	H1	G1	Q
1	KS112M	4-8	28	+0.009 -0.004	60	31	8	+0 -0.036	7	+0 -0.090	24	+0 -0.2	112	+0 -0.5	190	140	70	345	12	15	252	330	226	45	170	50	610	672.5	610	672.5	T28	M16x1.5	60	42	5	5	3	3
2	KS132M	4-8	38	+0.018 +0.002	80	41	10	+0 -0.036	8	+0 -0.090	33	+0 -0.2	132	+0 -0.5	216	178	89	358	12	15	300	380	260	55	220	55	700	785	700	785	T38	M20x1.5	80	54	8	7	4	5
3	KS160M	4-8	42	+0.018 +0.002	110	45	12	+0 -0.043	8	+0 -0.090	37	+0 -0.2	160	+0 -0.5	254	210	108	347	15	20	350	440	305	55	305	92.5	815	932	815	932	T42	M24x2	110	82 [Ⓢ]	10	8	5	5
4	KS160L	4-8	42	+0.018 +0.002	110	45	12	+0 -0.043	8	+0 -0.090	37	+0 -0.2	160	+0 -0.5	254	254	108	347	15	20	350	440	305	55	305	92.5	815	932	815	932	T42	M24x2	110	82 [Ⓢ]	10	8	5	5
5	KS180L	4-8	48	+0.018 +0.002	110	51.5	14	+0 -0.043	9	+0 -0.090	42.5	+0 -0.2	180	+0 -0.5	279	279	121	370	15	21	445	490	340	75	340 [Ⓢ]	85	875	990	875	990	T48	M30x2	110	82	12	8	5	5
6	KS200L	4-8	55	+0.030 +0.011	110	59	16	+0 -0.052	10	+0 -0.090	49	+0 -0.2	200	+0 -0.5	318	305	133	399	19	25	450 [Ⓢ]	545	400	89	365	95	947 [Ⓢ]	1057	947 [Ⓢ]	1057	T55	M36x3	110	82	14	9	5.5	5

09	14.04.14	'E2' Dimension for Pt.No. 3 & 4 Changed to 82 was 87		
08	07.07.11	Unification of KS160 M&L Frame		
07	06.06.11	EARTHING TERMINAL INCORPORATED		
06	19.07.10	'G' Dimn. for Pt.1 Changed to 24mm. was 27mm.		
05	14.12.07	COMPANY NAME AND LOGO CHANGED		
04	05.05.06	'BB' Dimension for KS180 Frame was 394 mm. 'AC' Dimension for KS200 Frame was 494 mm. 'L' & 'L1' Dimension for KS20 Frame was 942 mm.		
03	11.09.04	DRAWING GENERALLY REVISED		
B	10.11.97	'L' & 'L1' DIM. ALTERED (OLD 704) FOR PT.2	B.B.	S.B.
A	19.04.97	'G' FOR PART 3 & 4 CHANGED	B.B.	S.B.
REVISION	DATE	DETAIL OF REVISION	DONE BY	APPRVD

ALL DIMENSIONS ARE IN MILLIMETRE



Marathon Electric
A Regal Beloit Company

Marathon Electric Motors (India) Limited
Paharpur Works, 58 Taratala Road.
Kolkata - 700024, INDIA

TITLE: OUTLINE DIMENSION DRAWING FOR 112M TO 200L
(KRANE MOTOR.)

DRAWN	B.BISWAS	23.07.96		DRAWING NO.	REV.
CHECKED	S.BHOWMICK	23.07.96		CM1383	09
APPRVD.	R.RANJAN	23.07.96	SCALE IF ANY		
	SIGN	DATE	N.T.S		