

PRODUCT INFORMATION PACKET

marathon®
Motors

Model No: KS1P8011A60U33XSX

Catalog No: AL08D1630MFAFTOAOO

1.8 kW, Crane Duty Slipping Motors , 3 phase, 6 Pole, 415 V, S3 Duty, KS112M Frame, 60 CDF,
6 Start/Hr., TEFC



Regal and Marathon are trademarks of Regal Rexnord Corporation or one of its affiliated companies.

©2023 Regal Rexnord Corporation, All Rights Reserved. MC017097E

RegalRexnord

Nameplate Specifications

Output HP	2.40 Hp	Output KW	1.8 kW
Frequency	50 Hz	Voltage	415 V
Current	5.6 A	Speed	915 rpm
Phase	3	Duty	S3
Frame	KS112M	Enclosure	Totally Enclosed Fan Cooled
Thermal Protection	No Protection	Ambient Temperature	45 °C
Drive End Bearing Size	6306 ZZ	Opp Drive End Bearing Size	6306 ZZ
UL	No	CSA	No
CE	No	IP Code	55
CDF	60 %	Start/Hr	6
RA	9.2 A	RV	115 V
Insulation class Stator/Rotor	F/F	Temp. Rise Stator/Rotor	75/75 K
Stator Connection	Star	Rotor Connection	Star
Efficiency Class	Standard		

Technical Specifications

Electrical Type	Slipping	Starting Method	Rotor resistance starter
Rotation	Bi-Directional	Mounting	B3
Motor Orientation	Horizontal	Drive End Bearing	Antifriction
Opp Drive End Bearing	Antifriction	Frame Material	Cast Iron/Fabricated
Shaft Type	Single Cylinder	Overall Length	610.00 mm
Frame Length	610.00 mm	Shaft Diameter	28.000 mm
Shaft Extension	60 mm	Assembly/Box Mounting	Top
Rotor GD2	0.07 kg·m²	Pull Out Torque	3
Connection Drawing	DP1949	Outline Drawing	CM1383

These drawing and design are the property of Marathon Electric Motors (India) Limited. These must not be copied or lent to any other party without the written consent of Marathon Electric Motors (India) Limited.



PT. NO.	FRAME	POLE	D(SHAFT DIA)		E	GA	F		GD		G		H		FIXING DIMENSIONS				K	HA	AC	HD	AB	AA	BB	BA	L	LC	L1	LC1	TAPER SHAFT DIMENSIONS DETAILS (BOTH)							
			NOM.	TOL.			NOM.	TOL.	NOM.	TOL.	NOM.	TOL.	NOM.	TOL.	A	B	C	CA													D1	D2	E1	E2	F1	H1	G1	Q
1	KS112M	4-8	28	+0.009 -0.004	60	31	8	+0 -0.036	7	+0 -0.090	24	+0 -0.2	112	+0 -0.5	190	140	70	345	12	15	252	330	226	45	170	50	610	672.5	610	672.5	T28	M16x1.5	60	42	5	5	3	3
2	KS132M	4-8	38	+0.018 +0.002	80	41	10	+0 -0.036	8	+0 -0.090	33	+0 -0.2	132	+0 -0.5	216	178	89	358	12	15	300	380	260	55	220	55	700	785	700	785	T38	M20x1.5	80	54	8	7	4	5
3	KS160M	4-8	42	+0.018 +0.002	110	45	12	+0 -0.043	8	+0 -0.090	37	+0 -0.2	160	+0 -0.5	254	210	108	347	15	20	350	440	305	55	305	92.5	815	932	815	932	T42	M24x2	110	82 [Ⓢ]	10	8	5	5
4	KS160L	4-8	42	+0.018 +0.002	110	45	12	+0 -0.043	8	+0 -0.090	37	+0 -0.2	160	+0 -0.5	254	254	108	347	15	20	350	440	305	55	305	92.5	815	932	815	932	T42	M24x2	110	82 [Ⓢ]	10	8	5	5
5	KS180L	4-8	48	+0.018 +0.002	110	51.5	14	+0 -0.043	9	+0 -0.090	42.5	+0 -0.2	180	+0 -0.5	279	279	121	370	15	21	445	490	340	75	340 [Ⓢ]	85	875	990	875	990	T48	M30x2	110	82	12	8	5	5
6	KS200L	4-8	55	+0.030 +0.011	110	59	16	+0 -0.052	10	+0 -0.090	49	+0 -0.2	200	+0 -0.5	318	305	133	399	19	25	450 [Ⓢ]	545	400	89	365	95	947 [Ⓢ]	1057	947 [Ⓢ]	1057	T55	M36x3	110	82	14	9	5.5	5

09	14.04.14	'E2' Dimension for Pt.No. 3 & 4 Changed to 82 was 87		
08	07.07.11	Unification of KS160 M&L Frame		
07	06.06.11	EARTHING TERMINAL INCORPORATED		
06	19.07.10	'G' Dimn. for Pt.1 Changed to 24mm. was 27mm.		
05	14.12.07	COMPANY NAME AND LOGO CHANGED		
04	05.05.06	'BB' Dimension for KS180 Frame was 394 mm. 'AC' Dimension for KS200 Frame was 494 mm. 'L' & 'L1' Dimension for KS20 Frame was 942 mm.		
03	11.09.04	DRAWING GENERALLY REVISED		
B	10.11.97	'L' & 'L1' DIM. ALTERED (OLD 704) FOR PT.2	B.B.	S.B.
A	19.04.97	'G' FOR PART 3 & 4 CHANGED	B.B.	S.B.
REVISION	DATE	DETAIL OF REVISION	DONE BY	APPRVD

ALL DIMENSIONS ARE IN MILLIMETRE



Marathon Electric
A Regal Beloit Company

Marathon Electric Motors (India) Limited
Paharpur Works, 58 Taratala Road.
Kolkata - 700024, INDIA

TITLE: OUTLINE DIMENSION DRAWING FOR 112M TO 200L
(KRANE MOTOR.)

DRAWN	B.BISWAS	23.07.96			DRAWING NO.	REV.
CHECKED	S.BHOWMICK	23.07.96			CM1383	09
APPRVD.	R.RANJAN	23.07.96	SCALE IF ANY			
	SIGN	DATE	N.T.S			

REV	DRAWING NO.
03	15 DP 1949 03

For General Tolerance, Definition of various Symbols and Instructions refer Drawing No. C12.R7.12. C12DD2676, PLEASE ENQUIRE
 *(Rev. No.) should be taken from online "Drawing Master"

These drawing and design are the property of Marathon Electric Motors (India) Limited. These must not be copied or lent to any other party without the written consent of Marathon Electric Motors (India) Limited.

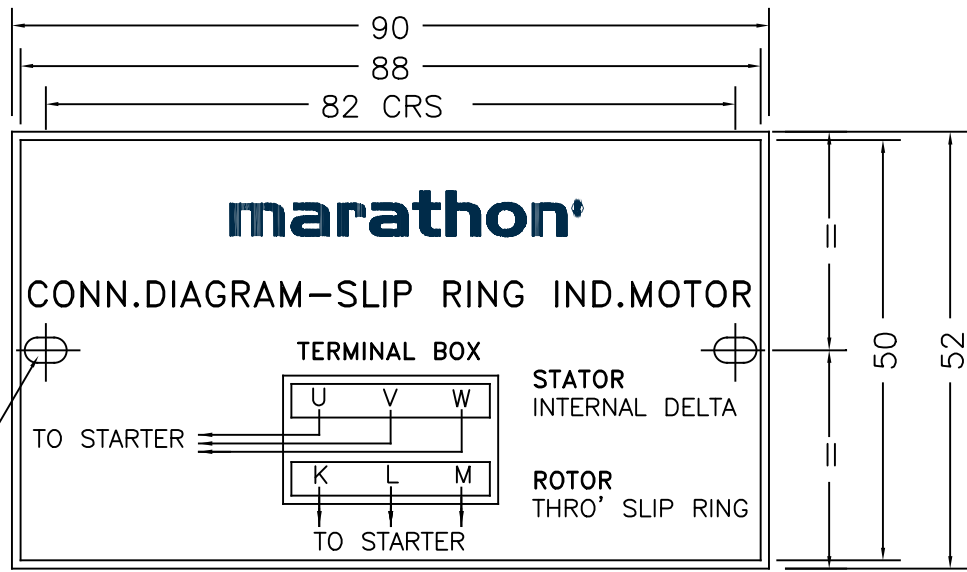

2-ELONGATED HOLES 5x3.5 (FOR PART 1 ONLY)

NOTE:-

- 1) THE HEIGHT OF LETTERS-2.5 & 2mm
- 2) LETTERS TO BE BOLD & THICK.
- 3) ALL LETTERS AND BORDER TO BE BLACK ON NATURAL BACK GROUND

2	BLACK PRINT ON POLYSTER FLIM WITH HIGH TRACK ACRYLIC ADHESIVE BACKING TO WITHSTAND TEMP.UPTO 100°C
1	ALUMINIUM 1mm THICK.ALL LETTERS TO BE ANODISED IN BLACK ON NATURAL BACKGROUND
PART NO.	MATERIAL / FINISH

REF: IS4728-1975

marathon Marathon Electric Motors (India) Limited
 Paharpur Works, 58 Taratala Road.
 Kolkata - 700024, INDIA

REVISION	DATE	DETAIL OF REVISION	DONE BY	APPRVD	DONE BY	APPRVD
03	12.12.07	LOGO CHANGED			C12DD2676	C12DC1285
02	27.07.07	DRAWING EXTENDED FOR RW 89 -105 RANGE			C12DD2645	C12DC1272
01	08.04.99	ALSTOM 'LOGO' INTRODUCED	B.B			

TITLE CONNECTION DIAGRAM FOR SR/KS & RW89-105 FRAME MOTOR 3(STATOR) & 3(ROTOR)

DRAWN	S.B	26.6.97	DRAWING NO.	REV
CHECKED	K.DAS			
APPRVD.	R.RANJAN		C12.R7.12.	15 DP 1949 03
SCALE	5 of 6	DATE		

Model No. KS1P8011A60U33XSX

Part No.

AL08D1630MFAFTOAOO

P	P	n	POT	T	U	f	I	RA	RV	CDF	Duty	No. of Starts/Hr.	Frame
[kW]	[hp]	[RPM]	XFLT	[Nm]	(V)	[Hz]	[A]			%			
1.8	2.4	915	3	55	415	50	5.6	9.2	115	60	S3	6	KS112M

Motor type	Slipring	Degree of protection	IP-55
Enclosure	TEFC	Motor weight - approx.	109 kg
Frame Material	-	Gross weight- approx.	kg
Mounting type	IMB3	Motor GD2	0.07 kgm ²
Cooling method	IC411	Vibration level	As per IS:12075 mm/s
Voltage variation	+/-10%	Noise level (1meter distance from motor)	As per IS:12065 dB(A)
Frequency variation	+/-5%	Starting method	Rotor resistance starter
Combined variation	10%	Coupling	Direct / Gearbox
Insulation class	F/F	Direction of rotation	Bi-directional
Ambient temperature	45	Paint shade	RAL5011
Temperature rise (by resistance)	75/75	Type of Terminal Box	Standard
Altitude above sea level	Upto 1000	Terminal box position	Top
Efficiency		Max. Cable size	Refer to TBA drg.
Power Factor		Bearing type	Antifriction
Stator Connection	Star	DE Bearing	6306 ZZ
Rotor Connection	Star	NDE Bearing	6306 ZZ
		Type of Lubrication	Grease

NOTE

All performance values at rated voltage and frequency.

All performance parameters are subjected to standard tolerance as per IEC 60034-1

Technical data are subject to change. There may be discrepancies between calculated and name plate values.