

# PRODUCT INFORMATION PACKET

Model No: KS1P7013B60X44XSX

Catalog No: KS1P7013B60X44XSX

1.7 Kw, Crane Duty Slipring Motors , 3 phase, 8 Pole, 415 V, S4 Duty, KS132MB Frame, 60 CDF,  
600 Start/Hr., TEFC



Regal and Marathon are trademarks of Regal Rexnord Corporation or one of its affiliated companies.

©2023 Regal Rexnord Corporation, All Rights Reserved. MC017097E

### Nameplate Specifications

Output HP	<b>2.30 Hp</b>	Output KW	<b>1.7 kW</b>
Frequency	<b>50 Hz</b>	Voltage	<b>415 V</b>
Current	<b>5.5 A</b>	Speed	<b>720 rpm</b>
Phase	<b>3</b>	Duty	<b>S4</b>
Frame	<b>KS132MB</b>	Enclosure	<b>Totally Enclosed Fan Cooled</b>
Thermal Protection	<b>No Protection</b>	Ambient Temperature	<b>45 °C</b>
Drive End Bearing Size	<b>6308 ZZ</b>	Opp Drive End Bearing Size	<b>6308 ZZ</b>
UL	<b>No</b>	CSA	<b>No</b>
CE	<b>No</b>	IP Code	<b>55</b>
CDF	<b>60 %</b>	Start/Hr	<b>600</b>
RA	<b>9.3 A</b>	RV	<b>110 V</b>
Insulation class Stator/Rotor	<b>F/F</b>	Temp. Rise Stator/Rotor	<b>75/75 K</b>
Stator Connection	<b>Delta</b>	Rotor Connection	<b>Star</b>
Efficiency Class	<b>Standard</b>		

### Technical Specifications

Electrical Type	<b>Slipping</b>	Starting Method	<b>Rotor resistance starter</b>
Rotation	<b>Bi-Directional</b>	Mounting	<b>IMB3</b>
Motor Orientation	<b>Horizontal</b>	Drive End Bearing	<b>Antifriction</b>
Opp Drive End Bearing	<b>Antifriction</b>	Frame Material	<b>Cast Iron/Fabricated</b>
Shaft Type	<b>Single Cylinder</b>	Overall Length	<b>700.00 mm</b>
Frame Length	<b>700.00 mm</b>	Shaft Diameter	<b>38.000 mm</b>
Shaft Extension	<b>80 mm</b>	Assembly/Box Mounting	<b>Top</b>
Rotor GD2	<b>0.19 kg·m<sup>2</sup></b>	Pull Out Torque	<b>3.9</b>
Outline Drawing	<b>CM1383</b>	Connection Drawing	<b>DP2017</b>



These drawing and design are the property of Marathon Electric Motors (India) Limited. These must not be copied or lent to any other party without the written consent of Marathon Electric Motors (India) Limited.

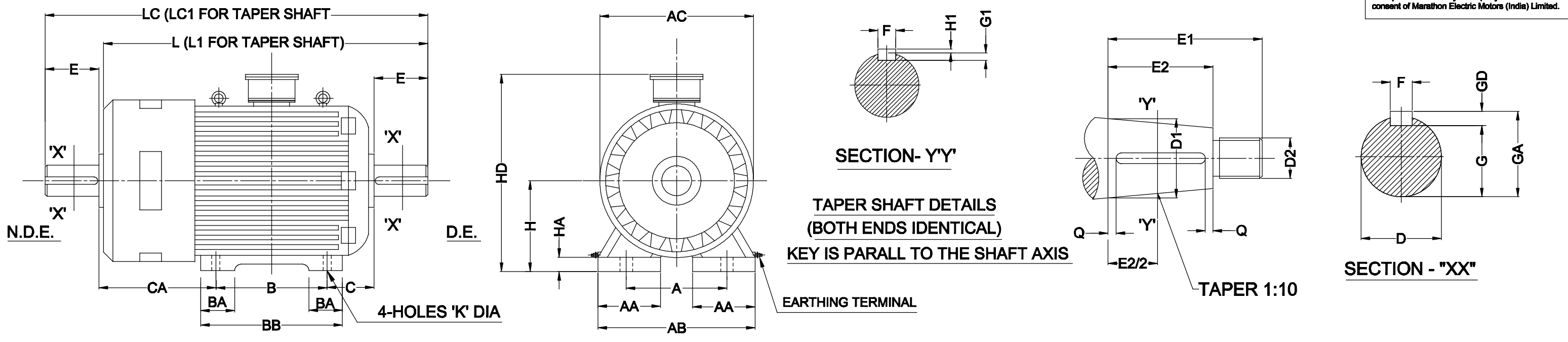

PT. NO.	FRAME	POLE	D(SHAFT DIA)		E	GA	F		GD		G		H		FIXING DIMENSIONS				K	HA	AC	HD	AB	AA	BB	BA	L	LC	L1	LC1	TAPER SHAFT DIMENSIONS DETAILS (BOTH)							
			NOM.	TOL.			NOM.	TOL.	NOM.	TOL.	NOM.	TOL.	NOM.	TOL.	A	B	C	CA													D1	D2	E1	E2	F1	H1	G1	Q
1	KS112M	4-8	28	+0.009 -0.004	60	31	8	+0 -0.036	7	+0 -0.090	24	+0 -0.2	112	+0 -0.5	190	140	70	345	12	15	252	330	226	45	170	50	610	672.5	610	672.5	T28	M16x1.5	60	42	5	5	3	3
2	KS132M	4-8	38	+0.018 +0.002	80	41	10	+0 -0.036	8	+0 -0.090	33	+0 -0.2	132	+0 -0.5	216	178	89	358	12	15	300	380	260	55	220	55	700	785	700	785	T38	M20x1.5	80	54	8	7	4	5
3	KS160M	4-8	42	+0.018 +0.002	110	45	12	+0 -0.043	8	+0 -0.090	37	+0 -0.2	160	+0 -0.5	254	210	108	347	15	20	350	440	305	55	305	92.5	815	932	815	932	T42	M24x2	110	82 <sup>Ⓢ</sup>	10	8	5	5
4	KS160L	4-8	42	+0.018 +0.002	110	45	12	+0 -0.043	8	+0 -0.090	37	+0 -0.2	160	+0 -0.5	254	254	108	347	15	20	350	440	305	55	305	92.5	815	932	815	932	T42	M24x2	110	82 <sup>Ⓢ</sup>	10	8	5	5
5	KS180L	4-8	48	+0.018 +0.002	110	51.5	14	+0 -0.043	9	+0 -0.090	42.5	+0 -0.2	180	+0 -0.5	279	279	121	370	15	21	445	490	340	75	340 <sup>Ⓢ</sup>	85	875	990	875	990	T48	M30x2	110	82	12	8	5	5
6	KS200L	4-8	55	+0.030 +0.011	110	59	16	+0 -0.052	10	+0 -0.090	49	+0 -0.2	200	+0 -0.5	318	305	133	399	19	25	450 <sup>Ⓢ</sup>	545	400	89	365	95	947 <sup>Ⓢ</sup>	1057	947 <sup>Ⓢ</sup>	1057	T55	M36x3	110	82	14	9	5.5	5

09	14.04.14	'E2' Dimension for Pt.No. 3 & 4 Changed to 82 was 87		
08	07.07.11	Unification of KS160 M&L Frame		
07	06.06.11	EARTHING TERMINAL INCORPORATED		
06	19.07.10	'G' Dimn. for Pt.1 Changed to 24mm. was 27mm.		
05	14.12.07	COMPANY NAME AND LOGO CHANGED		
04	05.05.06	'BB' Dimension for KS180 Frame was 394 mm. 'AC' Dimension for KS200 Frame was 494 mm. 'L' & 'L1' Dimension for KS20 Frame was 942 mm.		
03	11.09.04	DRAWING GENERALLY REVISED		
B	10.11.97	'L' & 'L1' DIM. ALTERED (OLD 704) FOR PT.2	B.B.	S.B.
A	19.04.97	'G' FOR PART 3 & 4 CHANGED	B.B.	S.B.
REVISION	DATE	DETAIL OF REVISION	DONE BY	APPRVD

ALL DIMENSIONS ARE IN MILLIMETRE

**marathon electric**  
A Regal Beloit Company

Marathon Electric Motors (India) Limited  
Paharpur Works, 58 Taratala Road.  
Kolkata - 700024, INDIA

TITLE: OUTLINE DIMENSION DRAWING FOR 112M TO 200L  
(KRANE MOTOR.)

DRAWN	B.BISWAS	23.07.96		DRAWING NO.	REV.
CHECKED	S.BHOWMICK	23.07.96		CM1383	09
APPRVD.	R.RANJAN	23.07.96	SCALE IF ANY		
	SIGN	DATE	N.T.S		

**Model No.** KS1P7013B60X44XSX

**Part No.**

P	P	n	POT	T	U	f	I	RA	RV	CDF	Duty	No. of Starts/Hr.	Frame
[kW]	[hp]	[RPM]	XFLT	[Nm]	(V)	[Hz]	[A]			%			
1.7	2.3	720	3.9	102	415	50	5.5	9.3	110	60	S4	600	KS132MB

Motor type	Slipring	Degree of protection	IP-55
Enclosure	TEFC	Motor weight - approx.	115 kg
Frame Material	-	Gross weight- approx.	kg
Mounting type	IMB3	Motor GD2	0.19 kgm <sup>2</sup>
Cooling method	IC411	Vibration level	As per IS:12075 mm/s
Voltage variation	+/-10%	Noise level ( 1meter distance from motor)	As per IS:12065 dB(A)
Frequency variation	+/-5%	Starting method	Rotor resistance starter
Combined variation	10%	Coupling	Direct / Gearbox
Insulation class	F/F	Direction of rotation	Bi-directional
Ambient temperature	45	Paint shade	RAL5011
Temperature rise (by resistance)	75/75	Type of Terminal Box	Standard
Altitude above sea level	Upto 1000	Terminal box position	Top
Efficiency		Max. Cable size	Refer to TBA drg.
Power Factor		Bearing type	Antifriction
Stator Connection	Delta	DE Bearing	6308 ZZ
Rotor Connection	Star	NDE Bearing	6308 ZZ
		Type of Lubrication	Grease

**NOTE**

All performance values at rated voltage and frequency.

All performance parameters are subjected to standard tolerance as per IEC 60034-1

Technical data are subject to change. There may be discrepancies between calculated and name plate values.