

PRODUCT INFORMATION PACKET



Model No: K321M2
Catalog No: K321M2
Crop Dryer Motor, 10 HP, 1 Ph, 60 Hz, 200-230 V, 3600 RPM, 215TZ Frame, ODP



Regal and Century are trademarks of Regal Rexnord Corporation or one of its affiliated companies.
©2022 Regal Rexnord Corporation, All Rights Reserved. MC017097E





Nameplate Specifications

Output HP	10 Hp	Output KW	7.5 kW
Frequency	60 Hz	Voltage	200-230 V
Current	44.5-41 A	Speed	3500 rpm
Service Factor	1	Phase	1
Duty	Continuous	Insulation Class	F
Frame	215TZ	Enclosure	Open Drip Proof
Thermal Protection	No Protection	Ambient Temperature	50 °C
UL	Recognized	CSA	Y
CE	N	Number of Speeds	1

Technical Specifications

Electrical Type	DC Permanent Magnet	Starting Method	Across The Line
Poles	2	Rotation	Selective Counterclockwise
Mounting	Rigid Base	Drive End Bearing	Ball
Opp Drive End Bearing	Ball	Frame Material	Rolled Steel
Shaft Type	Single Special Extension	Overall Length	20.32 in
Frame Length	12.40 in	Shaft Diameter	1.125 in
Shaft Extension	4.5 in		
Connection Drawing	EE9022PP-CY	Outline Drawing	037811CY

This is an uncontrolled document once printed or downloaded and is subject to change without notice. Date Created:11/29/2022

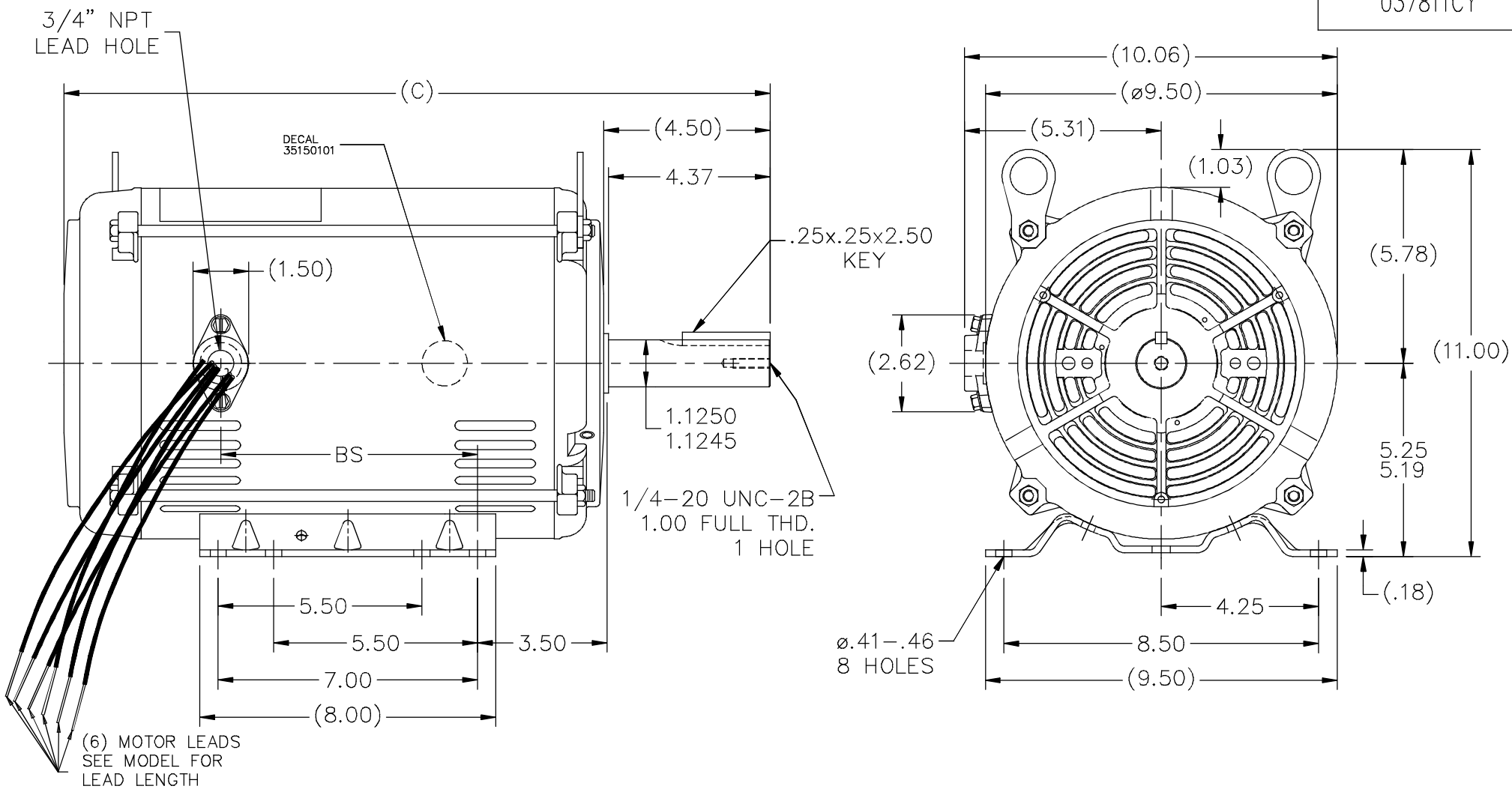

965	213TZ	17.57	5.43
1115	213T/215TZ	19.07	6.93
1240	213T/215TZ	20.32	8.18
DASH	FRAME	C	BS

NOTES:
1. NAMEPLATE TO BE READ FROM LEAD EXIT SIDE OF MOTOR.

				TOLERANCES UNLESS SPECIFIED			DRAWN GR 11/15/12		
				DEC.	INCHES		CHK SR 11/15/12		
				.X	±.1		APPD		
				.XX	±.03		SCALE 1=4		
				.XXX	±.005		REF SS89636LE		
				.XXXX	±.0005	MAT'L			
				ANG	±7'30"	FINISH			
NO.	REVISION	BY & DATE	CHK	ANG	±7'30"	PREV			
THIS DRAWING IN DESIGN AND DETAIL IS OUR PROPERTY AND MUST NOT BE USED EXCEPT IN CONNECTION WITH OUR WORK ALL RIGHTS OF DESIGN AND INVENTION ARE RESERVED THIS IS AN ELECTRONICALLY GENERATED DOCUMENT - DO NOT SCALE THIS PRINT				RFP	CAD FILE 037811CY	SIZE A	DRAWING NO. 037811CY	PAGE OF	REV.
				DIST					