

# PRODUCT INFORMATION PACKET

Model No: E3AB3004359B30D41100

Catalog No: E3AB3004359B30D41100

Made in Italy E3AB30 Series, General Purpose Low Voltage IEC motor IE3, Flameproof, 375,00kW,  
3 phase, 1489 RPM, D400/Y690V 50Hz, 355LD Frame B3, 4 Poles, IC411



Regal and CEMP are trademarks of Regal Rexnord Corporation or one of its affiliated companies.  
©2022 Regal Rexnord Corporation, All Rights Reserved. MC017097E

The logo for Regal Rexnord, featuring a stylized 'R' icon followed by the text 'RegalRexnord'.

### Nameplate Specifications

Output HP	<b>500 Hp</b>	Output KW	<b>375.0 kW</b>
Frequency	<b>50 Hz</b>	Voltage	<b>400/690 V</b>
Current	<b>630.0 A</b>	Speed	<b>1489 rpm</b>
Service Factor	<b>1</b>	Phase	<b>3</b>
Efficiency	<b>96 %</b>	Power Factor	<b>0.9</b>
Duty	<b>S1</b>	Insulation Class	<b>F</b>
Frame	<b>355LD</b>	Enclosure	<b>Totally Enclosed Fan Cooled</b>
Thermal Protection	<b>No Protection</b>	Ambient Temperature	<b>40 °C</b>
Drive End Bearing Size	<b>6322</b>	Opp Drive End Bearing Size	<b>6316</b>
UL	<b>No</b>	CSA	<b>No</b>
CE	<b>Yes</b>	IP Code	<b>IP55</b>
Number of Speeds	<b>1</b>		

### Technical Specifications

Electrical Type	<b>Squirrel Cage</b>	Starting Method	<b>Direct On Line</b>
Poles	<b>4</b>	Rotation	<b>Bi-Directional</b>
Mounting	<b>B3</b>	Motor Orientation	<b>Horizontal</b>
Drive End Bearing	<b>C3</b>	Opp Drive End Bearing	<b>C3</b>
Frame Material	<b>Cast Iron</b>	Shaft Type	<b>Keyed</b>
Overall Length	<b>1994.00 mm</b>	Frame Length	<b>1085.00 mm</b>
Shaft Diameter	<b>100.000 mm</b>	Shaft Extension	<b>210 mm</b>
Assembly/Box Mounting	<b>Top</b>		
Connection Drawing	<b>SC-01-T-1v-1a</b>	Outline Drawing	<b>B3A048350021A01</b>

This is an uncontrolled document once printed or downloaded and is subject to change without notice. Date Created:12/02/2022

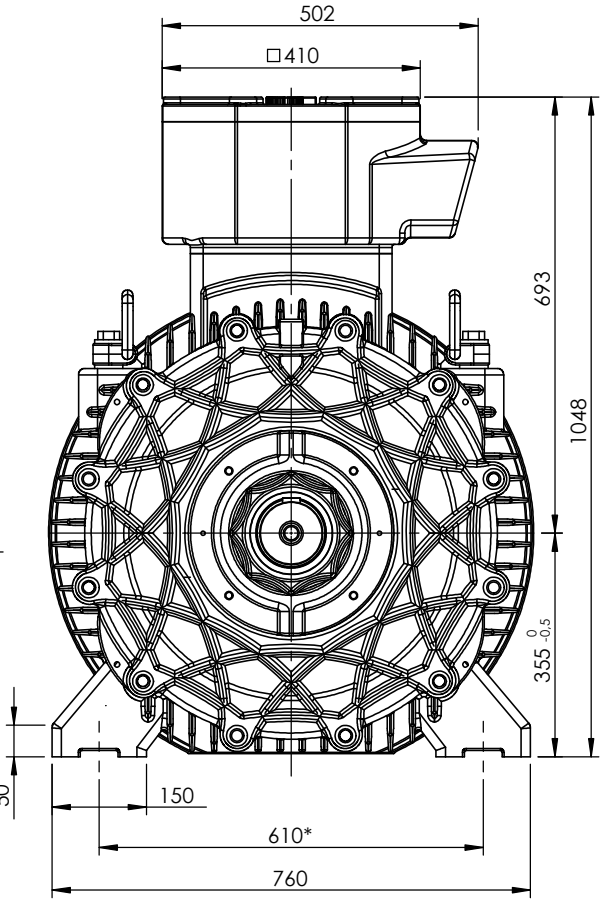
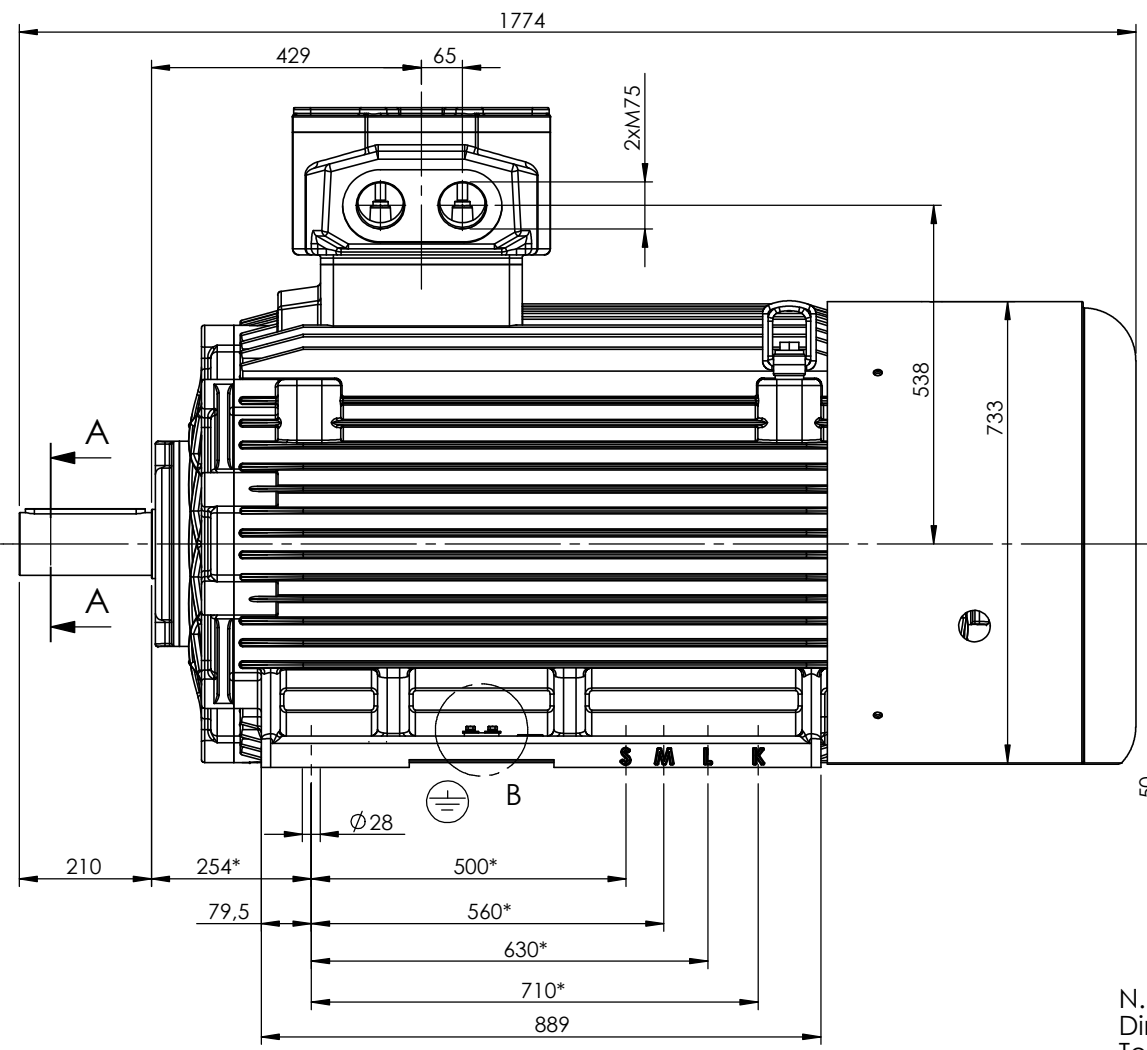
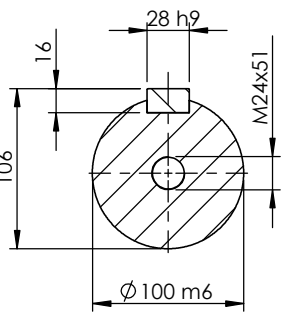
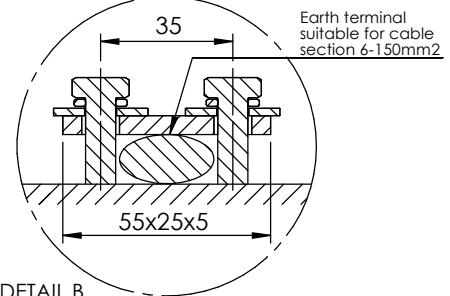

 Earth terminal: 1 in the terminal box, 2 on the frame.

N.B.  
Dimensions in mm. according to IEC 60072  
Tolerances where not differently marked ±2mm.  
\* Tolerances ±0.8

**Customer reference and additional information:**

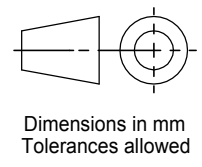

**Frame size: A 355LK 4-8 Poles**  
Document N. **B3A048350021A01** - Date 05/05/2015  
Issued by L.P. - Approved by D.P.  
Cemp - Senago (Italy)

Rev.	Motor type and description
0	

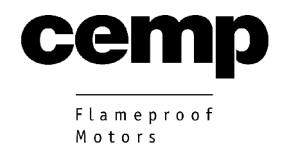

Schema di collegamento - *Connection diagram*  
Schemas de branchement - *Schaltplän*  
Esquemas de conexión



DTE 01/01/2004  
SC - 01 - T - 1v.doc

**Motori trifase una velocità - *Single speed, three phase motors* - Moteurs triphasé une vitesse  
*Drehstrommotor Eine Drehzahlstufe* - Motores trifásico una velocidad**



L1 - L2 - L3 = Linea - *Supply* - Reseau - *Netz* - Red  
Per invertire la rotazione invertire due fasi - *To change the rotation reverse two phases* - Pour changer le sens de rotation inverser deux phases - *Zur Drehrichtungsänderung zwei Phasen vertauschen* - Para invertir el sentido de rotación invertir dos fases

<b>Marcatura Morsetti Ausiliari - <i>Additional terminals marking (IEC60034-8)</i></b>		
<b>Marcatura <i>Marking</i></b>	<b>No. morsetti <i>terminals</i></b>	<b>Morsetto ausiliare per: <i>Additional terminal for:</i></b>
TP1A - TP2A (allarme- <i>warning</i> )	2	Termistori PTC (alta velocità) - <i>Thermistor PTC (high speed) [*]</i>
TP1B - TP2B (allarme- <i>warning</i> )	2	Termistori PTC (bassa velocità) - <i>Thermistor PTC (low speed) [*]</i>
R1 - R2 - R3 (I sensore - <i>sensor</i> )	3	
R4 - R5 - R6 (II sensore - <i>sensor</i> )	3	Termistore PT100 3 fili - <i>Thermistor PT 100 with 3 wires</i>
R7 - R8 - R9 (III sensore - <i>sensor</i> )	3	
R11 - R12 - R13 (anteriore - <i>DE</i> )	3	
R21 - R22 - R23 (posteriore - <i>NDE</i> )	3	Termistore PT100 su cuscinetto - <i>Thermistor PT 100 on bearing</i>
TB1 - TB2 (allarme- <i>warning</i> )	2	Protettore bimetallico normalmente chiuso -
TB3 - TB4 (intervento- <i>switch off</i> )	2	<i>Normally closed bi-metallic switch (**)</i>
TB8 - TB9 (intervento- <i>switch off</i> )	2	Protettore bimetallico del freno normalmente chiuso -
		<i>NC brake bi-metallic switch (**)</i>
TM1 - TM2 (allarme- <i>warning</i> )	2	Protettore bimetallico normalmente aperto -
TM3 - TM4 (intervento- <i>switch off</i> )	2	<i>Normally open bi-metallic switch (**)</i>
HE1- HE2	2	Resistenze riscaldanti - <i>Space heaters</i>
U1 - U2	2	Ventilazione ausiliaria monofase - <i>Single phase forced ventilation</i>
U - V - W	2	Ventilazione ausiliaria trifase - <i>Three phase forced ventilation</i>
colori secondo schema del produttore - <i>colours according manufacturer</i>	9	Encoder
CA1 - CA2	2	Condensatore - <i>Capacitor</i>
PE	1	Conduttore di terra - <i>Earth cable</i>

[\*] U nominale - *U rated* = 6V - max 30V(\*\*) U nominale - *U rated* = 250V

FOGLIO DATI PER MOTORI ELETTRICI ASINCRONI TRIFASI : SERIE IEC  
 DATA SHEET FOR ASYNCHRONOUS THREEPHASE INDUCTION MOTORS: IEC SERIES

Cliente / Customer	-
Ordine cliente / Customer order	-
Item	-

Conferma ordine / Acknowledgment	N° -
Impianto / Plant	-

## DATI DI PROGETTO - DESIGN DATA

Modo di protezione	II2G	Motore / Frame
Type of protection		Scatola morsetti / Terminal box
Tem. Amb. Min. / Min Amb.Temp.	-20	°C
Umidità relativa / Relative humidity	90%	
Tensione nominale / Rated Voltage	400 V ± 5%	

Ex-db IIB T4 Gb	IP55
Ex-db IIB Gb	IP55
Tem. Amb. Max. / Max Amb. Temp.	40 °C
Altitudine / Altitude	< 1000 mslm / masl
Frequenza / Frequency	50 Hz ± 2%

## DATI FUNZIONALI E COSTRUTTIVI - PERFORMANCE AND CONSTRUCTION DATA

1	Quantità / Quantity		01
2	Motore tipo / Motor type		AB30 355LD 4
3	Numero di serie / Serial Number		-
4	Forma costruttiva / Shape		B3
5	Certificato / Certificate	TÜV IT	15 ATEX 040 X
6	Altro certificato / Other certificate		
<b>Dati nominali / Rated data</b>			
7	Poli / Pole	n°	4
8	Potenza nominale / Rated power	kW	375,00
9	Corrente nominale / Rated current	A	629,76
10	Velocità nominale / Full Load speed	1/min	1490
11	Collegamento / Winding connection		D
12	Isolamento / Insulation class		F
13	Sovratemperatura / Temperature rise		80K
14	Raffreddamento / Cooling type		IC411
15	Fattore di servizio / Service factor		1
16			
17	Classe di rendimento / Efficiency level	IEC 34-30	IE3
<b>Performances elettriche / Electrical performances</b>			
	Carico / Load	4/4	3/4
18	Giri / Speed	1/min	1490
19	Corr. / Curr.	A	629,76
20	Rend / Eff	%	96,0
21	cos φ	-	0,90
<b>Performances all'avviamento / Starting performances</b>			
22	Ia/In - LRC/FLC	%	700
23	Cosphi a rotore bloccato / LR power factor		0,33
	Tempo a rotore bloccato / LRWT		
24	100% Un (A caldo / Warm)	sec	3
25	(A freddo / Cold)	sec	21
26	80% Un (A caldo / Warm)	sec	5
27	(A freddo / Cold)	sec	33
	Tempo di avviamento ammissibile / ART		
28	100% Un	sec	18
29	80% Un	sec	29
<b>Curva di coppia / Speed-torque values</b>			
30	Coppia nominale / Rated Torque	Nm	2402,78
31	Ca/Cn - LRT/FLT	%	190
32	Cmax/Cn - BDT/FLT	%	0
33			
34			
35			
<b>Varie / Other</b>			
36			
37			
38			
39			

<b>Servizio / Duty</b>			
40	Servizio / Duty type	-	S1
41	Intermittenza / Cyclic duration factor	-	-
42	Avviamenti-ora / Starting-hour	-	-
43	Tempo ciclo / Time		-
<b>Cuscinetti / Bearings</b>			
44	Cuscinetto ant / DE bearing	-	6322 C3
45	Cuscinetto post / NDE bearing	-	6316 C3
46	Carico radiale max / Max radial load in X1	N	-
47	Carico assiale max / Max axial load	N	-
48	Tipo grasso / Grease type	LGHP2 SKF or equivalent	
49	Intervallo lubrificazione / Lubrication	h	-
50	Quantità grasso / Quantity grease	gr	-
<b>Caratteristiche meccaniche / mechanical specification</b>			
51	Massa / Mass	kg	2490
52	Momento d'inerzia / Moment of inertia	kgm2	11,9000
53	Rumore a vuoto / Noise at no load (1 m)	Lp dB(A)	82
54	Vibrazioni / Vibration level	IEC 34-14	A
55	Limite norma / Vibration limit	mm/sec	2,80
56			
57			
<b>Dati entrata cavi - verniciatura / Cable entry and painting</b>			
63	Entrata cavi / Cable entry		2xM75
64	Ciclo verniciatura / Painting cycle		STD
65	Colore finale / Final colour	RAL	5010
66			
67			
68			
69			
70			
71			
<b>Ausiliari - Auxiliaries</b>			
72	Sonde termiche / Temperature detector	winding	-
73	Sonde termiche / Temperature detector	bearing	-
74	Scaldiglie / Heaters	V / W	-
75	Preparation for SPM sensor		-
76	Pressacavi / Cable glands		NO
77			

### CURVA COPPIA/CORRENTE-GIRI TORQUE/CURRENT-SPEED DIAGRAM

Cliente / Customer	CEMP
Impianto / Plant	-
<b>ITEM</b>	-
Numero d'offerta / Offer Number	2021.
	-

<b>Motore / Motor</b>	<b>AB30 355LD 4</b>	
Potenza nominale / Rated power	375,00	kW
Poli / Pole	4	
Tensione - Frequenza / Voltage - Frequency	400 - 50	V - Hz
Corrente / Rated current	629,76	A
Velocità / Speed	1490	rpm
Coppia / Torque	2402,78	Nm

— COPPIA - TORQUE    — CORRENTE - CURRENT

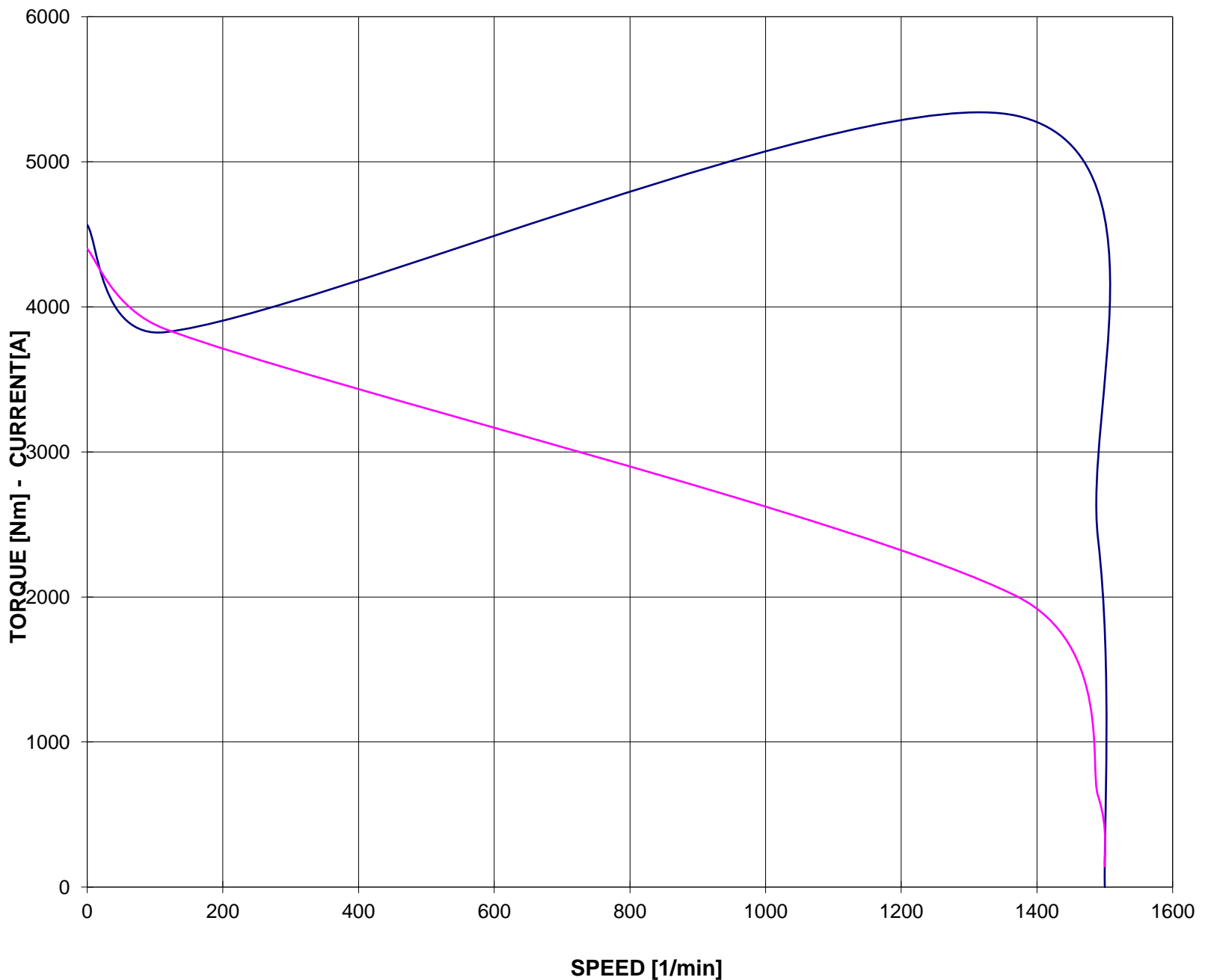

Valori calcolati - Data obtained by calculation method

**CURVA COPPIA/CORRENTE-GIRI (Tensione ridotta)**  
**TORQUE/CURRENT-SPEED DIAGRAM (Reduced voltage)**

Cliente / Customer	CEMP
Impianto / Plant	-
<b>ITEM</b>	-
Numero d'offerta / Offer Number	2021.
	-

<b>Motore / Motor</b>	<b>AB30 355LD 4</b>	
Potenza nominale / Rated power	375,00	kW
Poli / Pole	4	
Tensione - Frequenza / Voltage - Frequency	400 - 50	V - Hz
Corrente / Rated current	629,76	A
Velocità / Speed	1490	rpm
Coppia / Torque	2402,78	Nm

— COPPIA - TORQUE	— CORRENTE - CURRENT
- - - COPPIA - TORQUE 80% Un	- - - CORRENTE - CURRENT 80% Un

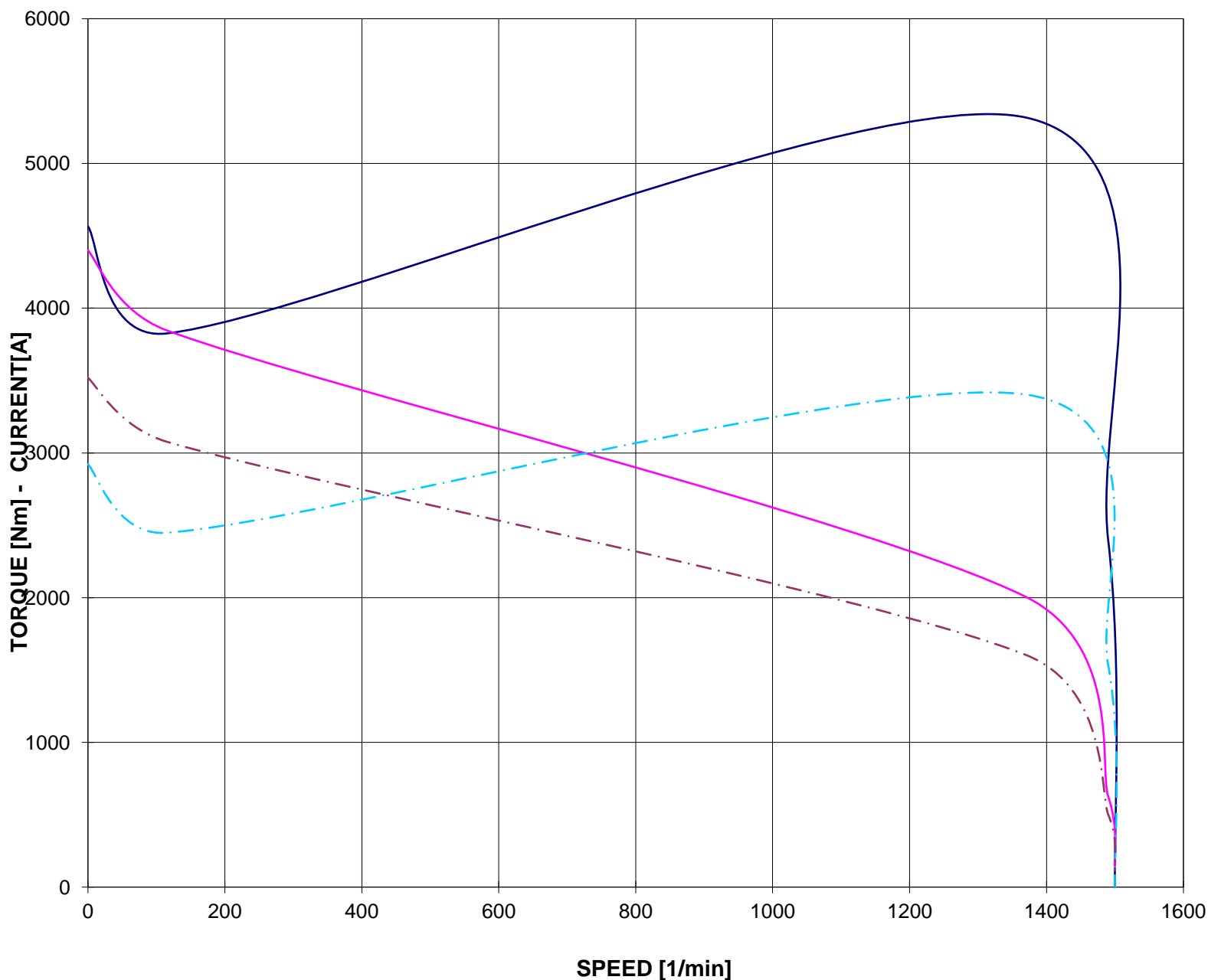

Valori calcolati - Data obtained by calculation method



### CURVE CARATTERISTICHE PERFORMANCE CURVES

Cliente / Customer CEMP  
 Impianto / Plant -  
**ITEM** -  
 Numero d'offerta / Offer Number 2021.  
 -

**Motore / Motor AB30 355LD 4**  
 Potenza nominale / Rated power 375,00 kW  
 Poli / Pole 4  
 Tensione - Frequenza / Voltage - Frequency 400 - 50 V - Hz  
 Corrente / Rated current 629,76 A  
 Velocità / Speed 1490 rpm  
 Coppia / Torque 2402,78 Nm

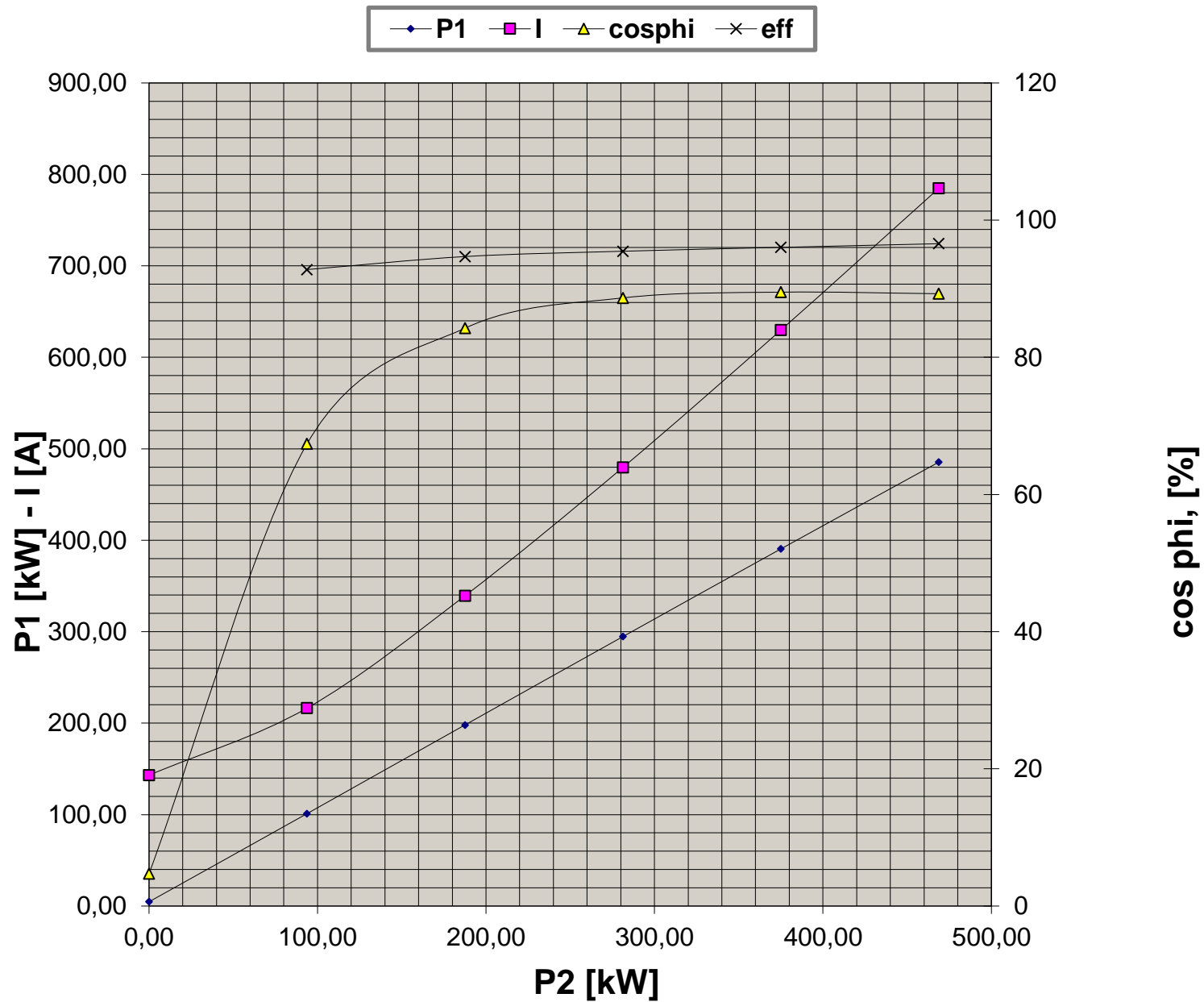

Valori calcolati - Data obtained by calculation method

### CURVA LIMITE CORRENTE TEMPO THERMAL WITHSTAND CURVE

Cliente / Customer	CEMP
Impianto / Plant	-
<b>ITEM</b>	-
Numero d'offerta / Offer Number	2021.
	-

<b>Motore / Motor</b>	<b>AB30 355LD 4</b>	
Potenza nominale / Rated power	375,00	kW
Poli / Pole	4	
Tensione - Frequenza / Voltage - Frequency	400 - 50	V - Hz
Corrente / Rated current	629,76	A
Velocità / Speed	1490	rpm
Coppia / Torque	2402,78	Nm

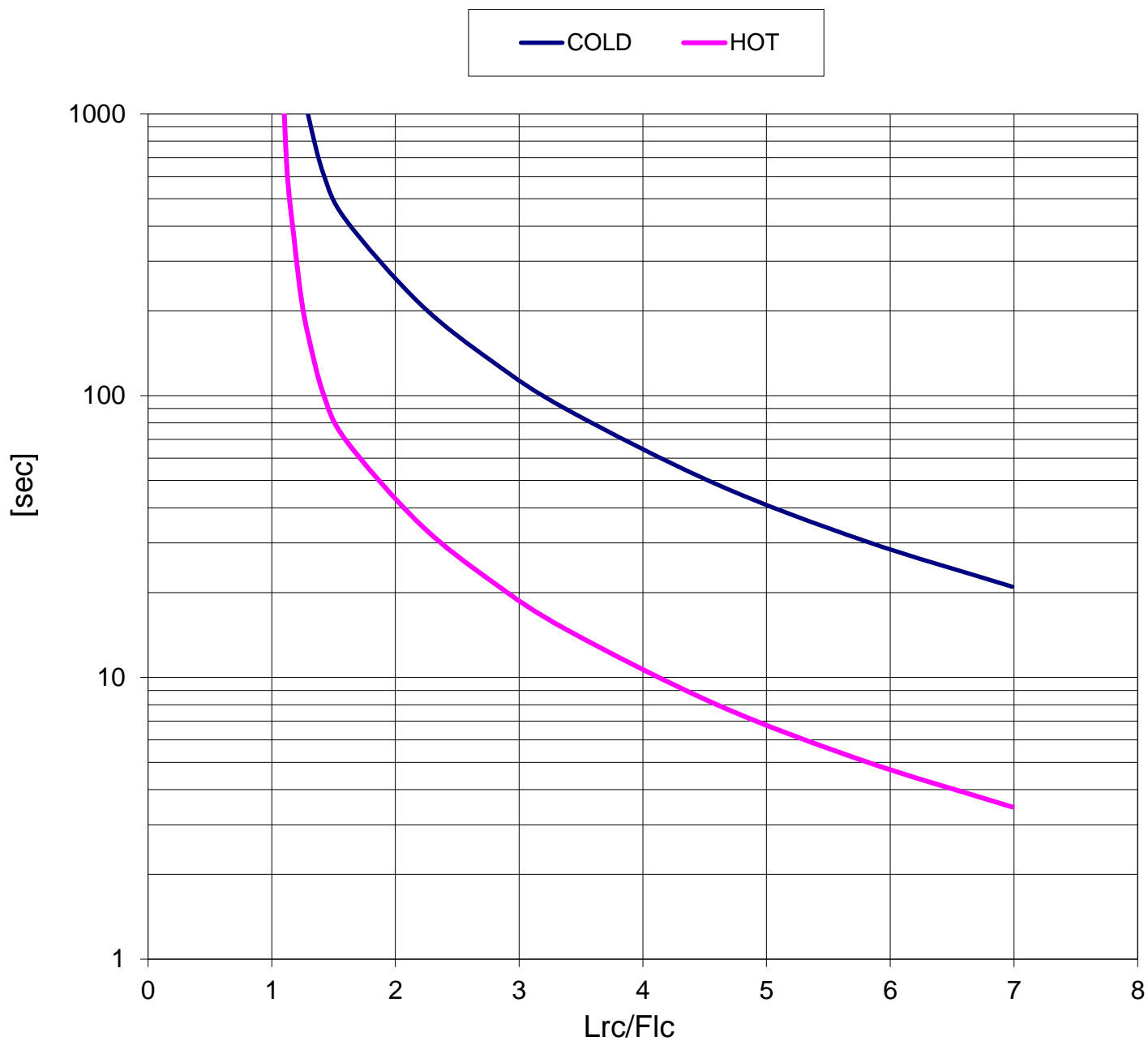

Valori calcolati - Data obtained by calculation method

**CURVA LIMITE CORRENTE TEMPO (Tensione ridotta)**  
**THERMAL WITHSTAND CURVE (Reduced voltage)**

Cliente / Customer	CEMP
Impianto / Plant	-
<b>ITEM</b>	-
Numero d'offerta / Offer Number	2021.
	-

<b>Motore / Motor</b>	<b>AB30 355LD 4</b>	
Potenza nominale / Rated power	375,00	kW
Poli / Pole	4	
Tensione - Frequenza / Voltage - Frequency	400 - 50	V - Hz
Corrente / Rated current	629,76	A
Velocità / Speed	1490	rpm
Coppia / Torque	2402,78	Nm

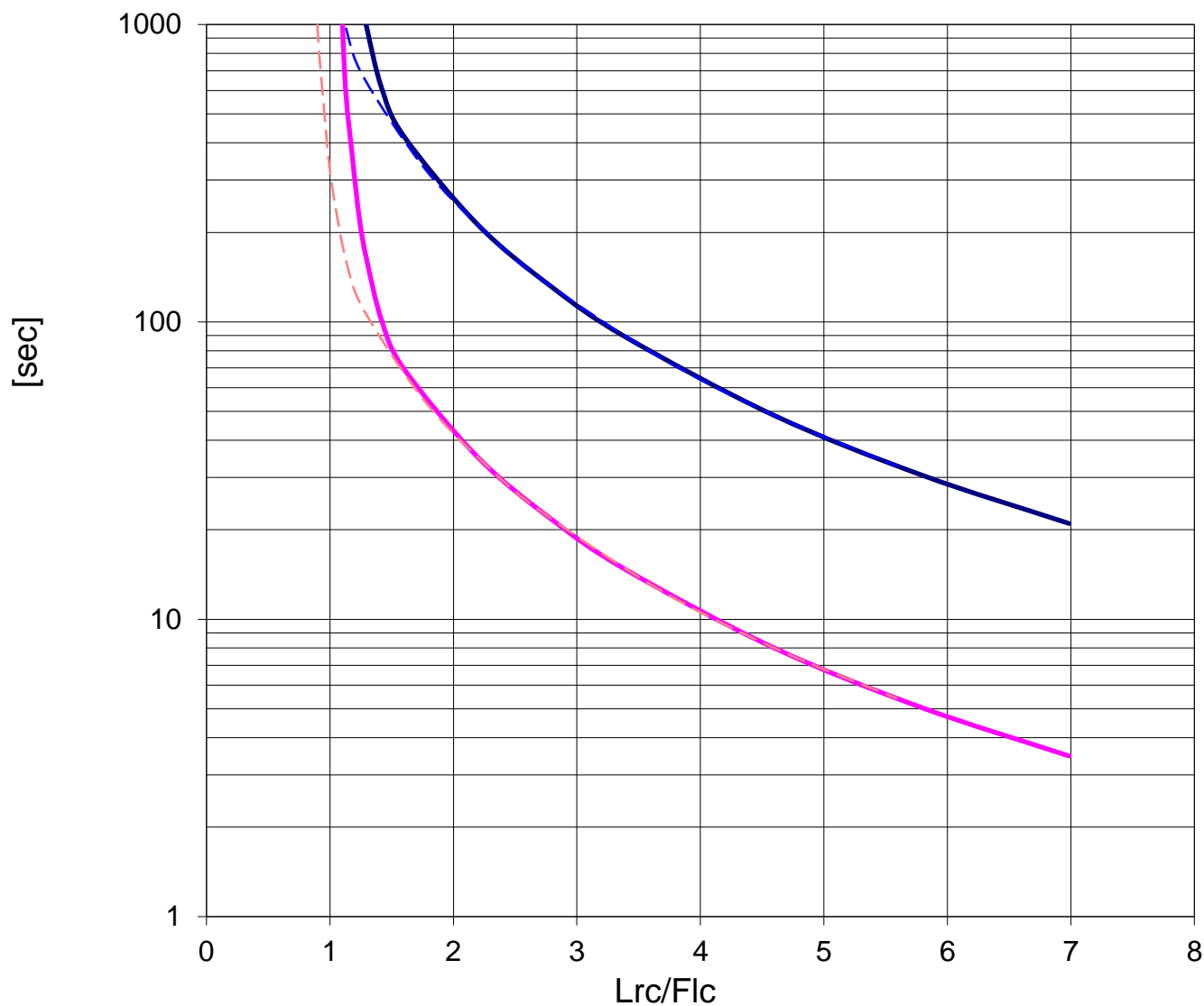
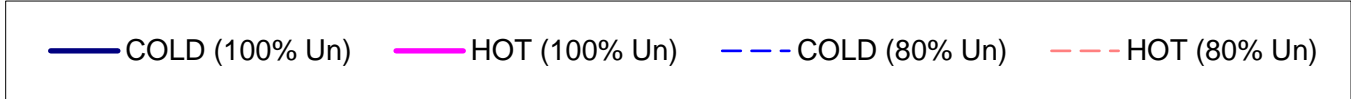

Valori calcolati - Data obtained by calculation method