

# PRODUCT INFORMATION PACKET



Model No: 825412.00  
Catalog No: 825412.00  
Explosion Proof Motor, 25 & 20 HP, 3 Ph, 60 & 50 Hz, 230/460 & 190/380 V, 1200 & 1000 RPM,  
324T Frame, EPFC



Regal and Leeson are trademarks of Regal Rexnord Corporation or one of its affiliated companies.  
©2023 Regal Rexnord Corporation, All Rights Reserved. MC017097E





### Nameplate Specifications

Phase	<b>3</b>	Output HP	<b>25 &amp; 20 Hp</b>
Output KW	<b>18.7 &amp; 14.9 kW</b>	Voltage	<b>230/460 &amp; 190/380 V</b>
Speed	<b>1182 &amp; 982 rpm</b>	Service Factor	<b>1.15 &amp; 1.15</b>
Frame	<b>324T</b>	Enclosure	<b>Explosion Proof Fan cooled</b>
Thermal Protection	<b>Thermostat</b>	Efficiency	<b>93 &amp; 92.4 %</b>
Ambient Temperature	<b>40 °C</b>	Frequency	<b>60 &amp; 50 Hz</b>
Current	<b>65/32.5 &amp; 63/31.5 A</b>	Power Factor	<b>78</b>
Duty	<b>Continuous</b>	Insulation Class	<b>F</b>
Design Code	<b>B</b>	KVA Code	<b>G</b>
Drive End Bearing Size	<b>6312</b>	Opp Drive End Bearing Size	<b>6311</b>
UL	<b>UL Listed And CSA Certified</b>	CSA	<b>Y</b>
CE	<b>N</b>	IP Code	<b>54</b>
Number of Speeds	<b>1</b>	Hazardous Location	<b>EXP PROOF CL I GR C&amp;D CL II GR F&amp;G T3B</b>

### Technical Specifications

Electrical Type	<b>Squirrel Cage Inverter Rated</b>	Starting Method	<b>Line Or Inverter</b>
Poles	<b>6</b>	Rotation	<b>Reversible</b>
Resistance Main	<b>.255 Ohms</b>	Mounting	<b>Rigid Base</b>
Motor Orientation	<b>Horizontal</b>	Drive End Bearing	<b>Ball</b>
Opp Drive End Bearing	<b>Ball</b>	Frame Material	<b>Cast Iron</b>
Shaft Type	<b>T</b>	Overall Length	<b>28.87 in</b>
Frame Length	<b>11.50 in</b>	Shaft Diameter	<b>2.125 in</b>
Shaft Extension	<b>5.25 in</b>	Assembly/Box Mounting	<b>F1 ONLY</b>
Inverter Load	<b>CONSTANT 10:1</b>		
Outline Drawing	<b>B-SS301018LE-1150</b>	Connection Drawing	<b>A-EE7308T-LE</b>



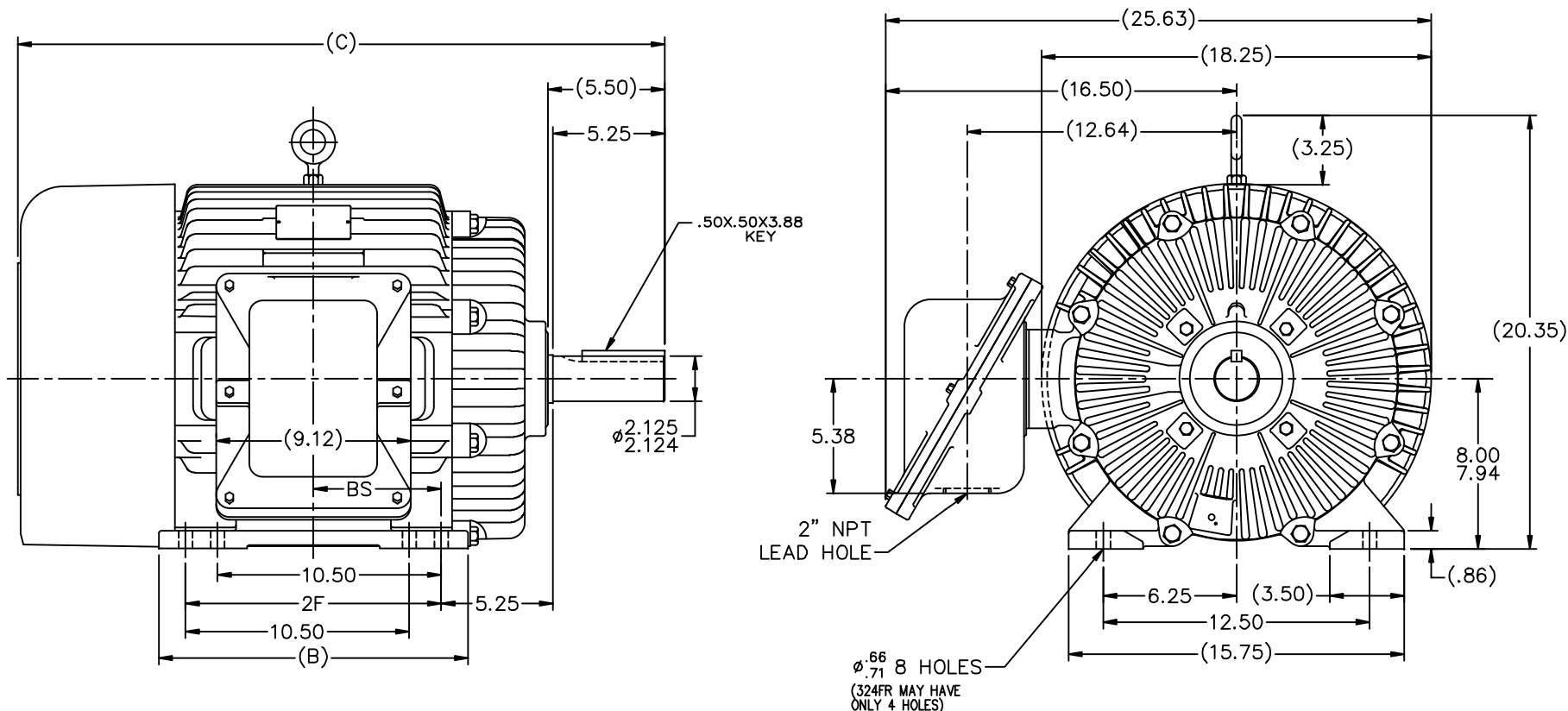

NOTES:

1. BOX CAN BE ROTATED IN 90° STEPS.
2. BOX CAN BE MOUNTED ON OPPOSITE SIDE BY REMOVING BRACKETS AND TURNING FRAME 180°.
3. NAMEPLATE TO BE READ FROM CONDUIT BOX SIDE OF MOTOR.

DASH	FR.	C	B	BS	2F
1300	324/326T	30.37	14.50	6.00	12.00

		TOLERANCES UNLESS SPECIFIED		 ELECTRIC MOTORS GEARMOTORS AND DRIVES	DRAWN RJW 12-14-2004	
		DEC.	INCHES		CHK	ML 12-15-2004
		.X	±.1			APPD DD 12-15-2004
		.XX	±.02	TITLE OUTLINE		SCALE 1=5
		.XXX	±.005	320T FR. - BB - TS - EXP. PR.		REF MU63761
1	REMOVED GROUND HOLE ANNOATION (MU106656)	REP	02-16-2012	TB	.XXXX ±.0005	FMF
NO.	REVISION	BY & DATE	CHK	ANG	FINISH	PREV
THIS DRAWING IN DESIGN AND DETAIL IS OUR PROPERTY AND MUST NOT BE USED EXCEPT IN CONNECTION WITH OUR WORK ALL RIGHTS OF DESIGN AND INVENTION ARE RESERVED THIS IS AN ELECTRONICALLY GENERATED DOCUMENT - DO NOT SCALE THIS PRINT				RFP	12-14-2004	CAD FILE SS301018LE
				DIST	LB	SIZE B
				DRAWING NO. PAGE OF		REV. 1
				SS301018LE		

THREE PHASE  
DUAL VOLTAGE MOTOR

HIGH VOLTAGE

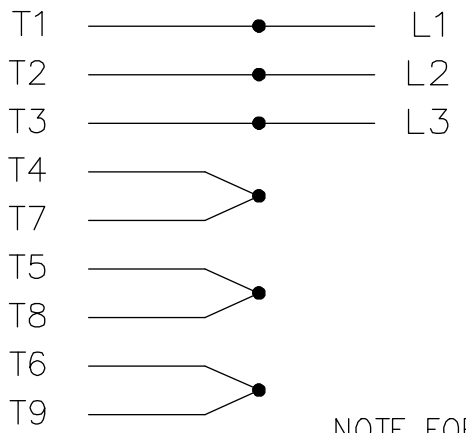

NOTE FOR FACTORY USE ONLY:  
 TO SURGE TEST FOR COMMON CONNECT:  
 HIGH VOLT: CONNECT P1 TO T1  
 THEN P2 TO L1  
 LOW VOLT: CONNECT P1 TO T1 & T7,  
 THEN P2 TO L1

LOW VOLTAGE

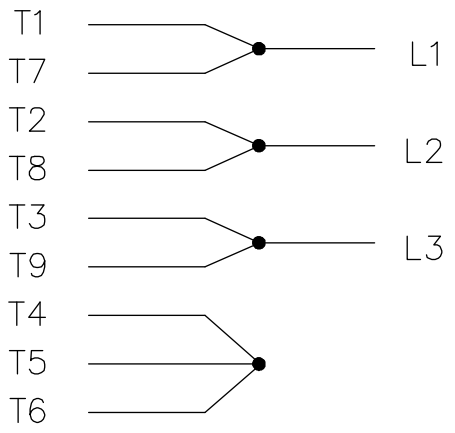

THREMO-PROTECTORS  
CONNECTED IN SERIES.

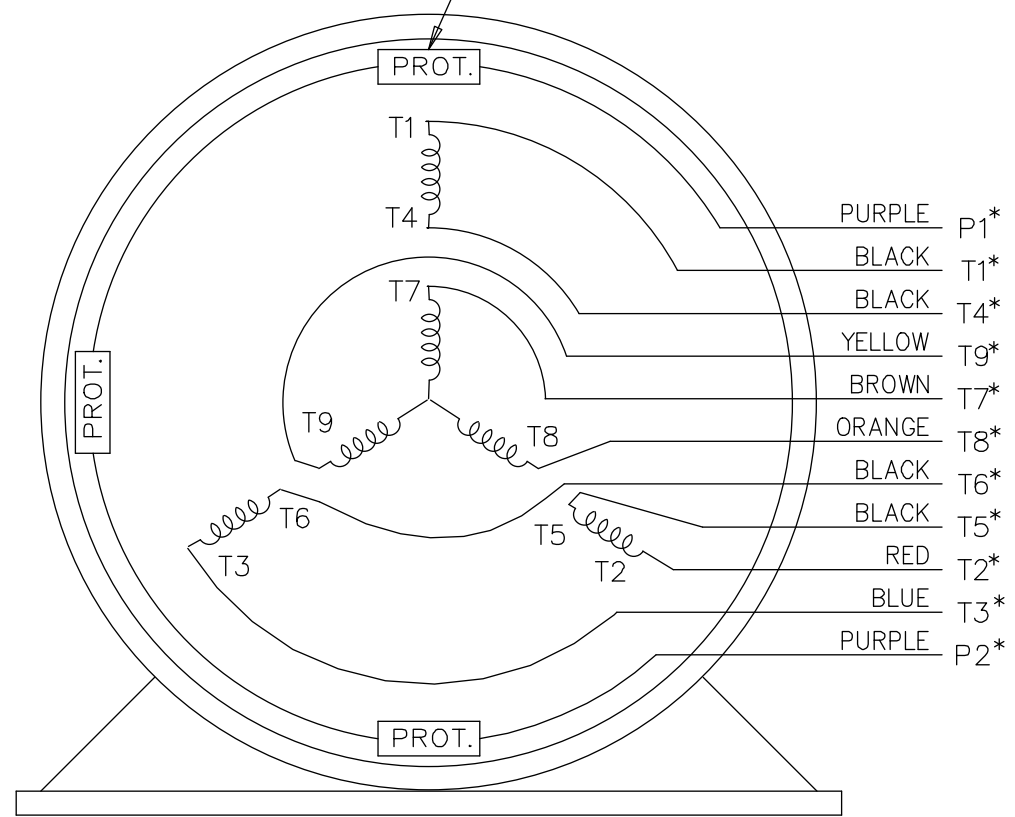

VIEW OF TERMINAL END

\* USE LEADS AS PER PLANT STANDARD IRRWSPECTIVE OF THEIR COLOUR.

NO.	REVISION	BY & DATE	CHK	ANG	TOLERANCES UNLESS SPECIFIED		FINISH	DRAWING NO.	PAGE	OF	REV.
					DEC.	INCHES					
05	ADDED * NOTE PER ECN # 26921	UD 01-30-2013	JD	DEC.	INCHES						
04	ADDED COLORS TO "T & P" LEADS CN 40494	MSG 08-08-2006	ML	.X	±.1						
03	RE-ISSUE	NJS 04-21-2004	JET	.XX	±.02						
02	REDRAWN	TAT 04-20-2004	ML	.XXX	±.005						
01	NEW DRAWING CN 34708	TJB 05-08-2002	ML	.XXXX	±.0005						
THIS DRAWING IN DESIGN AND DETAIL IS OUR PROPERTY AND MUST NOT BE USED EXCEPT IN CONNECTION WITH OUR WORK ALL RIGHTS OF DESIGN AND INVENTION ARE RESERVED THIS IS AN ELECTRONICALLY GENERATED DOCUMENT - DO NOT SCALE THIS PRINT							RFP	CAD FILE EE7308T_LE	SIZE A	DRAWING NO. EE7308T-LE	PAGE 05
							DIST LB-WP-LE				



ELECTRIC MOTORS  
GEARMOTORS  
AND DRIVES

TITLE CONNECTION DIAGRAM  
3 PHASE - DUAL VOLTAGE MOTOR

DRAWN	TJB	05-07-2002
CHK	ML	05-08-2002
APPD	TB	05-08-2002
SCALE	1=1	
REF		
FMF		
PREV		

P.O. BOX 8003  
 WAUSAU, WI 54401-8003  
 PH. 715-675-3311



DATA VOLTS: 460

**CERTIFICATION DATA SHEET**

CONN. DIAGRAM: A-EE7308T-LE  
 OUTLINE: B-SS301018LE-1150  
 WINDING: 324679

CAT #: 825412.00

NONE 3

**TYPICAL MOTOR PERFORMANCE DATA**

HP	KW	SYNC RPM	FL RPM	FRAME	ENCLOSURE	TYPE	KVA CODE	DESIGN
25	18.7	1200	1182	324T	TEFC	TFN	G	B

PH	HZ	VOLTS	AMPS	START TYPE	DUTY	INSL	S.F.	AMB	ELEV.
3	60/50	230/460#190/380	65/32.5&63/31.5	LINE OR INVERTER	CONT	F	1.15	40	3300

F.L. EFF	93.0	3/4 LD EFF	93.0	1/2 LD EFF	92.4	GTD EFF	ELECT. TYPE
F.L. PF	78.0	3/4 LD PF	73.0	1/2 LD PF	63.0	92.4	SQ CAGE INV RATED

F.L. TORQUE	LR AMPS @ 460 V	L.R. TORQUE	B.D. TORQUE	F.L. RISE (°C)
112 LB-FT	182	175 LB-FT 156%	300 LB-FT 268%	55

PRESSURE @ 3	POWER	ROTOR WK²	MAX. LOAD WK²	SAFE STALL TIME	STARTS/HOUR	MOTOR WGT
56 dBA	65 dBA	8.5 LB-FT²	425 LB-FT²	20 SEC.	2	650 LB.

\*\*\* SUPPLEMENTAL INFORMATION \*\*\*

DE BRACKET TYPE	ODE BRACKET TYPE	MOUNT TYPE	MOTOR ORIENTATION	SEVERE DUTY	HAZARDOUS LOCATION	DRIP COVER	SCREENS	PAINT
STANDARD	STANDARD	RIGID	HORIZONTAL	UM SEVERE	DF CL I GR C&D CL II GF	NO	NONE	BLUE (EPOXY)

BEARINGS		GREASE	SHAFT TYPE	SPECIAL DE	SPECIAL ODE	SHAFT MATERIAL	FRAME MATERIAL
DE	ODE	POLYREX EM	T	NONE	NONE	1045 HOT ROLLED (C-204)	CAST IRON
BALL	BALL						
6312	6311						

THERMOSTATS	PROTECTORS	WDG RTD's	BRG RTD's	THERMISTORS	CONTROL	SPACE HEATERS
TSTATS (N/C)	NOT	NONE	NONE	NONE	FALSE	NA

R1 (ohms/ph)	R2 (ohms/ph)	X1 (ohms/ph)	X2 (ohms/ph)	Xm (ohms/ph)	VIBRATION (in/sec)	FLOAT
0.176	0.136	1.046	1.305	18.115	0.080	ODE

* N O T E S *	INVERTER TORQUE: CONSTANT 10:1 INV. HP SPEED RANGE: NONE					
	ENCODER: NONE					
	NONE					
	NONE					
	NONE PPR					

DATE: 2/1/2018	BRAKE: NONE NONE NONE					
	FT-LB: NA					
	VOLTAGE: NONE HZ:					
	UL: NONE					

Data Sheet

Date: 2/1/2018

825412.00



Data @ 460 V

Motor Load Data

Load	0%	25%	50%	75%	100%	115%	125%	LR
Current (Amps)	14.0	15.8	20.0	25.5	32.5	37.0	39.5	182
Torque (ft-lb)	0.00	27.5	55.0	83.5	112	128	140	175
RPM	1200	1195	1190	1188	1182	1,178	1175	0
Efficiency (%)		88.5	92.4	93.0	93.0	93.0	92.4	
P.F. (%)	4.5	42.0	63.0	73.0	78.0	79.0	80.0	30.0

Motor Speed Data

	LR	Pull-Up	BD	Rated	Idle
Speed (RPM)	0	600	1100	1182	1200
Current (Amps)	182	168	125	32.5	14.0
Torque (ft-lb)	175	190	300	112	0.00

Information Block				
HP	25.0			
Sync. RPM	1200			
Frame	324			
Enclosure	TEFC			
Construction	TFN			
Voltage	230/460#190/380 V			
Frequency	60 Hz			
Design	B			
LR Code letter	G			
Service Factor	1.15			
Temp Rise @ FL	55 °C			
Duty	CONT			
Ambient	40 °C			
Elevation	1,000 feet			
Rotor/Shaft wk <sup>2</sup>	8.5 Lb-Ft <sup>2</sup>			
Ref Wdg	324679 NONE			
Sound Pressure @ 1M	56 dBA			
VFD Rating	CONSTANT 10:1			
Outline Dwg	B-SS301018LE-1150			
Conn. Diag	A-EE7308T-LE			
Additional Specifications:				
0				
0				
EQUIV CKT (OHMS / PHASE)				
R1	R2	X1	X2	Xm
0.1760	0.1360	1.0460	1.3050	18.1150

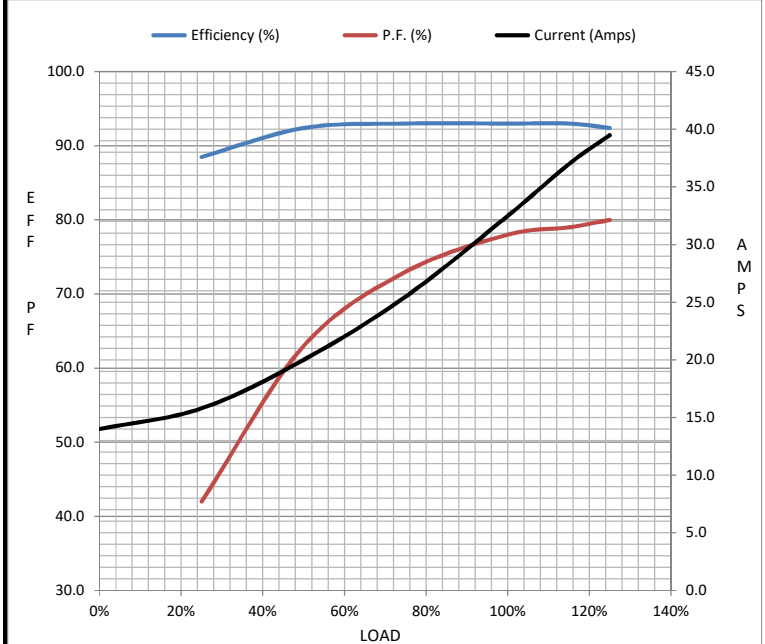

Speed - Torque Curve

