

PRODUCT INFORMATION PACKET



Model No: 825103.00

Catalog No: 825103.00

Explosion Proof Motor, 50 & 40 HP, 3 Ph, 60 & 50 Hz, 230/460 & 190/380 V, 1800 & 1500 RPM,
326T Frame, EPFC



Regal and Leeson are trademarks of Regal Rexnord Corporation or one of its affiliated companies.

©2023 Regal Rexnord Corporation, All Rights Reserved. MC017097E





Nameplate Specifications

Phase	3	Output HP	50 & 40 Hp
Output KW	37.0 & 30.0 kW	Voltage	230/460 & 190/380 V
Speed	1775 & 1475 rpm	Service Factor	1.0 & 1.0
Frame	326T	Enclosure	Explosion Proof Fan cooled
Thermal Protection	Thermostat	Efficiency	94.5 & 94.1 %
Ambient Temperature	40 °C	Frequency	60 & 50 Hz
Current	120/60 & 116/58 A	Power Factor	82
Duty	Continuous	Insulation Class	F
Design Code	B	KVA Code	F
Drive End Bearing Size	312	Opp Drive End Bearing Size	311
UL	UL Listed And CSA Certified	CSA	Y
CE	N	IP Code	54
Number of Speeds	1	Hazardous Location	EXP PROOF CL I GR C&D CL II GR F&G T3B

Technical Specifications

Electrical Type	Squirrel Cage Inverter Rated	Starting Method	Line Or Inverter
Poles	4	Rotation	Reversible
Resistance Main	.112 Ohms	Mounting	Rigid Base
Motor Orientation	Horizontal	Drive End Bearing	Ball
Opp Drive End Bearing	Ball	Frame Material	Cast Iron
Shaft Type	T	Overall Length	30.37 in
Frame Length	13.00 in	Shaft Diameter	2.125 in
Shaft Extension	5.25 in	Assembly/Box Mounting	F1 ONLY
Inverter Load	CONSTANT 2:1		
Outline Drawing	B-SS301018LE-1300	Connection Drawing	A-EE7308T-LE

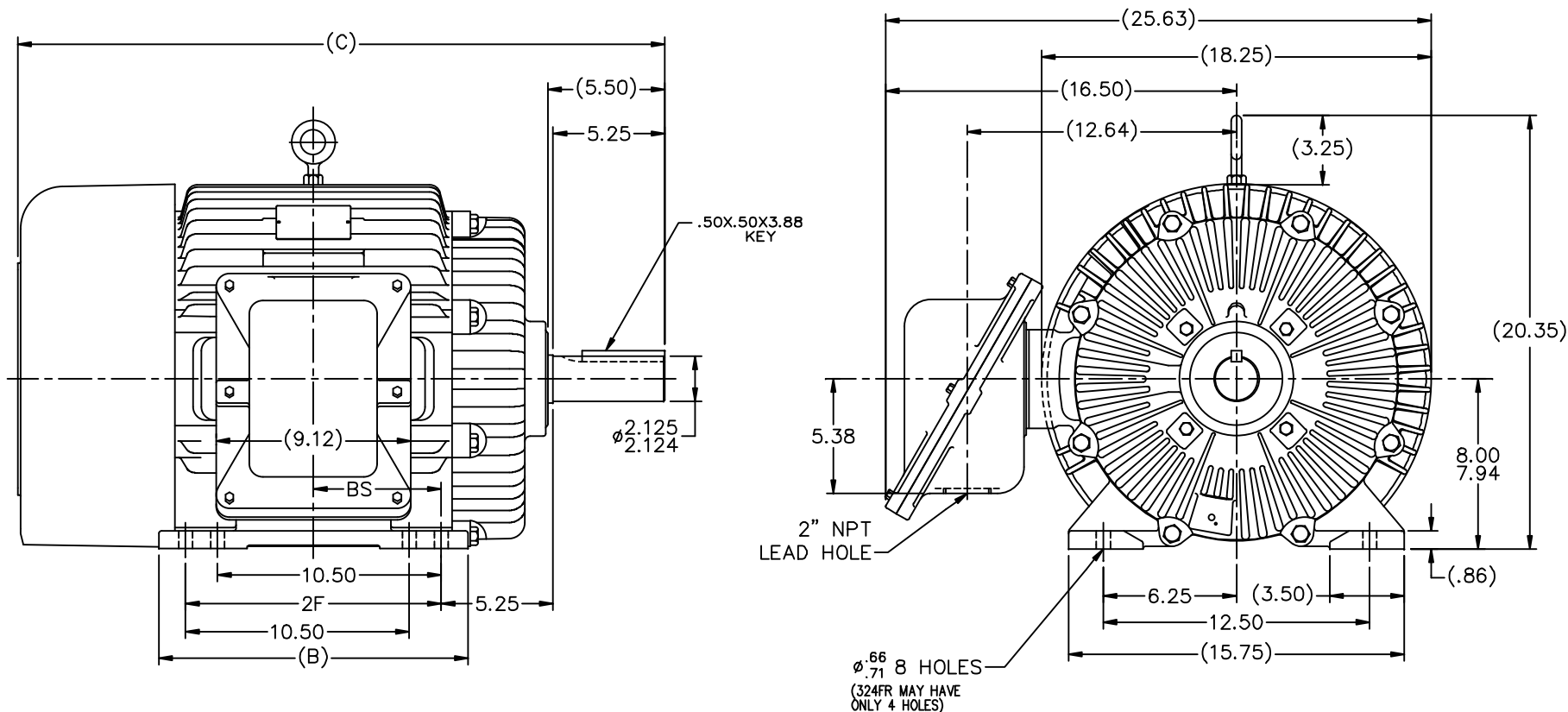

NOTES:

1. BOX CAN BE ROTATED IN 90° STEPS.
2. BOX CAN BE MOUNTED ON OPPOSITE SIDE BY REMOVING BRACKETS AND TURNING FRAME 180°.
3. NAMEPLATE TO BE READ FROM CONDUIT BOX SIDE OF MOTOR.

DASH	FR.	C	B	BS	2F
1300	324/326T	30.37	14.50	6.00	12.00

		TOLERANCES UNLESS SPECIFIED		 ELECTRIC MOTORS GEARMOTORS AND DRIVES		DRAWN RJW 12-14-2004							
		DEC.	INCHES			CHK	ML 12-15-2004						
		.X	±.1			APPD	DD 12-15-2004						
		.XX	±.02			SCALE	1=5						
		.XXX	±.005			REF	MU63761						
1	REMOVED GROUND HOLE ANNOATION (MU106656)	REP	02-16-2012	TB	.XXXX ±.0005	MAT'L	FMF						
NO.	REVISION	BY & DATE	CHK	ANG	±7'30"	FINISH	PREV						
THIS DRAWING IN DESIGN AND DETAIL IS OUR PROPERTY AND MUST NOT BE USED EXCEPT IN CONNECTION WITH OUR WORK ALL RIGHTS OF DESIGN AND INVENTION ARE RESERVED THIS IS AN ELECTRONICALLY GENERATED DOCUMENT - DO NOT SCALE THIS PRINT					RFP	12-14-2004	CAD FILE	SS301018LE	SIZE	DRAWING NO.	PAGE	OF	REV.
					DIST	LB	B	SS301018LE	B	SS301018LE	1	1	

THREE PHASE
DUAL VOLTAGE MOTOR

HIGH VOLTAGE

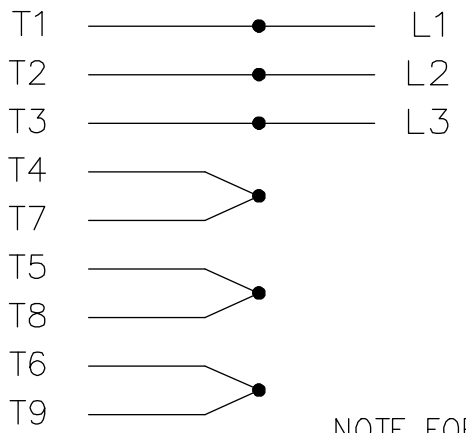

NOTE FOR FACTORY USE ONLY:
 TO SURGE TEST FOR COMMON CONNECT:
 HIGH VOLT: CONNECT P1 TO T1
 THEN P2 TO L1
 LOW VOLT: CONNECT P1 TO T1 & T7,
 THEN P2 TO L1

LOW VOLTAGE

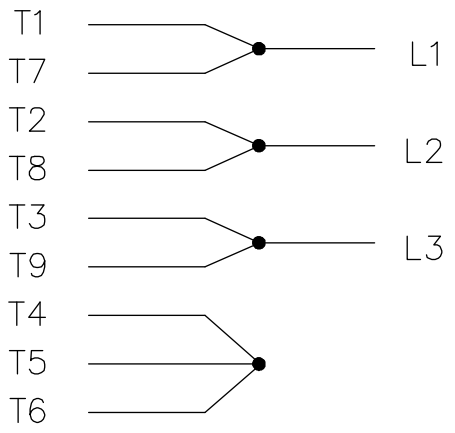

THREMO-PROTECTORS
CONNECTED IN SERIES.

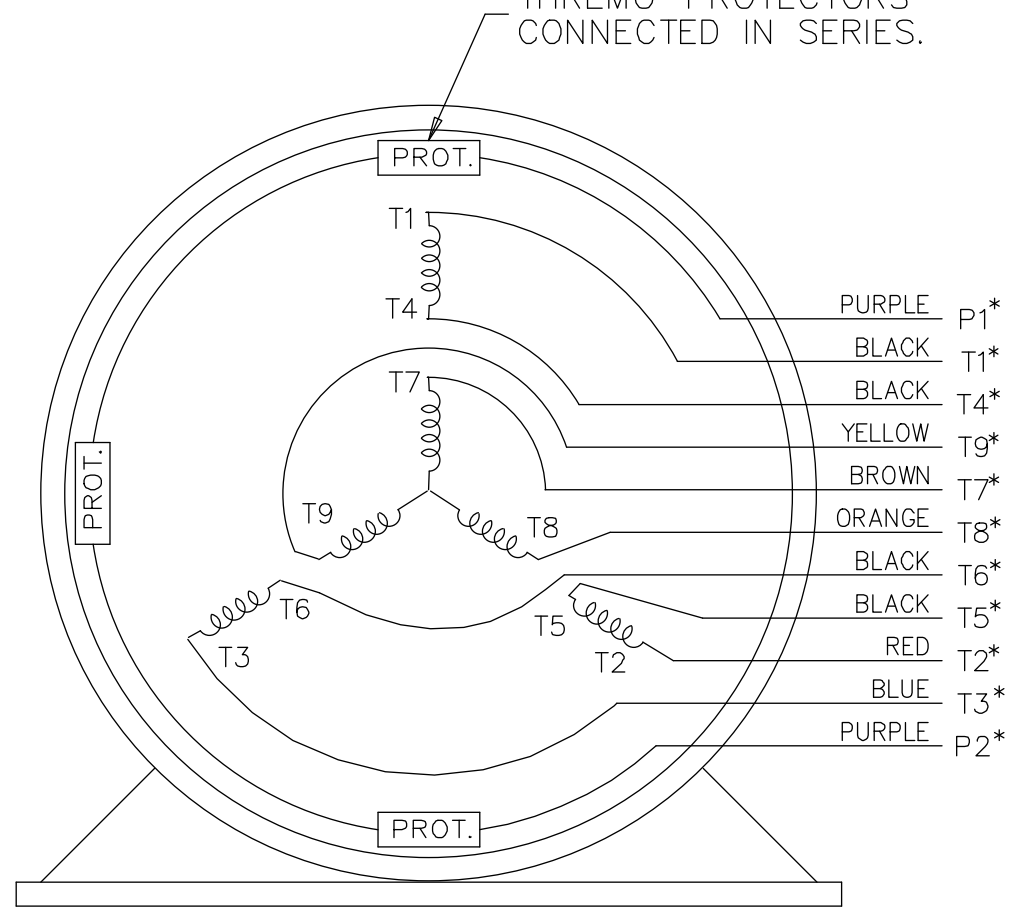

VIEW OF TERMINAL END

* USE LEADS AS PER PLANT STANDARD IRRWSPECTIVE OF THEIR COLOUR.

NO.	REVISION	BY & DATE	CHK	ANG	TOLERANCES UNLESS SPECIFIED		FINISH	DRAWING NO.	PAGE	OF	REV.
					DEC.	INCHES					
05	ADDED * NOTE PER ECN # 26921	UD 01-30-2013	JD	DEC.	INCHES						
04	ADDED COLORS TO "T & P" LEADS CN 40494	MSG 08-08-2006	ML	.X	±.1						
03	RE-ISSUE	NJS 04-21-2004	JET	.XX	±.02						
02	REDRAWN	TAT 04-20-2004	ML	.XXX	±.005						
01	NEW DRAWING CN 34708	TJB 05-08-2002	ML	.XXXX	±.0005						
THIS DRAWING IN DESIGN AND DETAIL IS OUR PROPERTY AND MUST NOT BE USED EXCEPT IN CONNECTION WITH OUR WORK ALL RIGHTS OF DESIGN AND INVENTION ARE RESERVED THIS IS AN ELECTRONICALLY GENERATED DOCUMENT - DO NOT SCALE THIS PRINT							RFP	CAD FILE EE7308T_LE	SIZE A	DRAWING NO. EE7308T-LE	PAGE 05
							DIST LB-WP-LE				



ELECTRIC MOTORS
GEARMOTORS
AND DRIVES

TITLE CONNECTION DIAGRAM
3 PHASE - DUAL VOLTAGE MOTOR

DRAWN	TJB	05-07-2002
CHK	ML	05-08-2002
APPD	TB	05-08-2002
SCALE	1=1	
REF		
FMF		
PREV		



CERTIFICATION DATA SHEET

**1051 CHEYENNE AVE.
GRAFTON, WI 53024
PH. 262-377-8810**

CONN. DIAGRAM: A-EE7308T-LE

CATALOG #: 825103.00

OUTLINE: B-SS301018LE-1300

MOUNTING: F1 ONLY

WINDING #: K3264168 1

TYPICAL MOTOR PERFORMANCE DATA

HP	kW	SYNC. RPM	F.L. RPM	FRAME	ENCLOSURE	KVA CODE	DESIGN
50&40	37.0&30.0	1800	1775&1470	326T	EPFC	F	B

PH	Hz	VOLTS	AMPS	START TYPE	DUTY	INSL	S.F.	AMB°C
3	60/50	230/460&190/380	120/60&116/58	LINE OR INVERTER	CONTINUOUS	F3	1.0/1.0	40

FULL LOAD EFF:	94.5&94.1	3/4 LOAD EFF:	94.5	1/2 LOAD EFF:	94.5	GTD. EFF	94.1	ELEC. TYPE	SQ CAGE INV RATED
FULL LOAD PF:	82&83	3/4 LOAD PF:	79	1/2 LOAD PF:	71				

F.L. TORQUE	LOCKED ROTOR AMPS	L.R. TORQUE	B,D. TORQUE	F.L. RISE°C
148 LB-FT	670 / 335	250 LB-FT 169 %	340 LB-FT 230 %	75

SOUND PRESSURE @ 3 FT.	SOUND POWER	ROTOR WK^2	MAX. WK^2	SAFE STALL TIME	STARTS / HOUR	APPROX. MOTOR WGT
65 dBA	75 dBA	9.7 LB-FT^2	325 LB-FT^2	25 SEC.	2	775 LBS.

***** SUPPLEMENTAL INFORMATION *****

DE BRACKET TYPE	ODE BRACKET TYPE	MOUNT TYPE	ORIENTATION	SEVERE DUTY	HAZARDOUS LOCATION	DRIP COVER	SCREENS	PAINT
STANDARD	STANDARD	RIGID	HORIZONTAL	PREMIUM SEVERE DUTY	EXP PROOF CL I GR C&D CL II GR F&G T3B	FALSE	NONE	BLUE - LEESON (ENAMEL)

BEARINGS		GREASE	SHAFT TYPE	SPECIAL DE	SPECIAL ODE	SHAFT MATERIAL	FRAME MATERIAL
DE	ODE						
BALL	BALL	POLYREX EM	T	NONE	NONE	1045 HOT ROLLED (C-204)	CAST IRON
312	311						

THERMO-PROTECTORS				THERMISTORS	CONTROL	SPACE HEATERS
THERMOSTATS	PROTECTORS	WDG RTDs	BRG RTDs			
TSTATS (N/C)	NOT	NONE	NONE	NONE	FALSE	NONE VOLTS

*
N
O
T
E

INVERTER TORQUE: CONSTANT 2:1
INV. HP SPEED RANGE: NONE
ENCODER: NONE NONE NONE NONE NONE PPR
BRAKE: NONE NONE NONE P/N NONE NONE NONE

Data Sheet

Date: 1/29/2018

825103.00



Data @ **460 V**

Motor Load Data

Load	0%	25%	50%	75%	100%	115%	125%	LR
Current (Amps)	24.0	27.5	36.0	47.0	60.0	68.5	75.0	335
Torque (ft-lb)	0.00	36.6	73.5	111	148	170	185	250
RPM	1800	1795	1788	1782	1775	1.772	1770	0
Efficiency (%)		91.7	94.5	94.5	94.5	94.1	93.6	
P.F. (%)	4.0	51.0	71.0	79.0	82.0	82.5	83.0	33.0

Motor Speed Data

	LR	Pull-Up	BD	Rated	Idle
Speed (RPM)	0	900	1675	1775	1800
Current (Amps)	335	300	190	60.0	24.0
Torque (ft-lb)	250	230	340	148	0.00

Information Block				
HP	50.0			
Sync. RPM	1800			
Frame	326			
Enclosure	TEFC			
Construction	TFN			
Voltage	230/460#190/380 V			
Frequency	60 Hz			
Design	B			
LR Code letter	F			
Service Factor	1.15			
Temp Rise @ FL	75 °C			
Duty	CONT			
Ambient	40 °C			
Elevation	1,000 feet			
Rotor/Shaft wk ²	9.7 Lb-Ft ²			
Ref Wdg	K3264168 NONE			
Sound Pressure @ 1M	65 dBA			
VFD Rating	CONSTANT 2:1			
Outline Dwg	B-SS301018LE-1300			
Conn. Diag	A-EE7308T-LE			
Additional Specifications:				
0				
0				
EQUIV CKT (OHMS / PHASE)				
R1	R2	X1	X2	Xm
0.0680	0.0620	0.4830	0.6480	11.0680

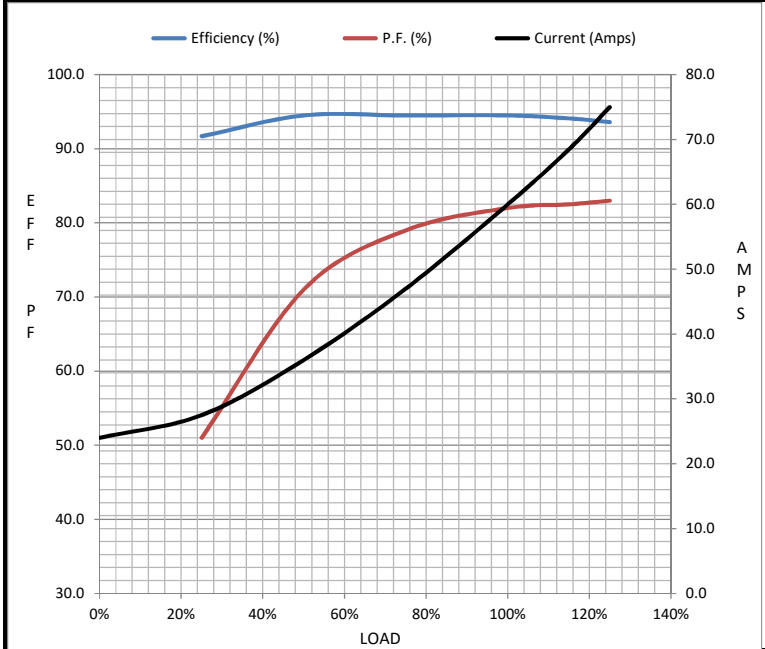

Speed - Torque Curve

