

PRODUCT INFORMATION PACKET



Model No: 825074.00

Catalog No: 825074.00

Explosion Proof Motor, 10 & 7.50 HP, 3 Ph, 60 & 50 Hz, 230/460 & 190/380 V, 3600 & 3000 RPM,
215TC Frame, EPFC



Regal and Leeson are trademarks of Regal Rexnord Corporation or one of its affiliated companies.

©2023 Regal Rexnord Corporation, All Rights Reserved. MC017097E





Nameplate Specifications

Phase	3	Output HP	10 & 7.5 Hp
Output KW	7.5 & 5.6 kW	Voltage	230/460 & 190/380 V
Speed	3535 & 2950 rpm	Service Factor	1.15 & 1.15
Frame	215TC	Enclosure	Explosion Proof Fan cooled
Thermal Protection	Thermostat	Efficiency	91.7 & 92 %
Ambient Temperature	40 °C	Frequency	60 & 50 Hz
Current	23.6/11.8 & 21/10.5 A	Power Factor	87
Duty	Continuous	Insulation Class	F
Design Code	B	KVA Code	H
Drive End Bearing Size	309	Opp Drive End Bearing Size	208
UL	UL Listed; also, UL Certified for Canada	CSA	N
CE	N	IP Code	54
Number of Speeds	1	Hazardous Location	EXP PROOF CL I GR C&D CL II GR F&G T3B

Technical Specifications

Electrical Type	Squirrel Cage Inverter Rated	Starting Method	Line Or Inverter
Poles	2	Rotation	Reversible
Resistance Main	.8 Ohms	Mounting	Rigid Base
Motor Orientation	Horizontal	Drive End Bearing	Ball
Opp Drive End Bearing	Ball	Frame Material	Cast Iron
Shaft Type	T	Overall Length	23.45 in
Frame Length	12.12 in	Shaft Diameter	1.375 in
Shaft Extension	3.38 in	Assembly/Box Mounting	F1 Only
Inverter Load	CONSTANT 10:1		
Connection Drawing	A-EE7308T-LE	Outline Drawing	037702LE-1212

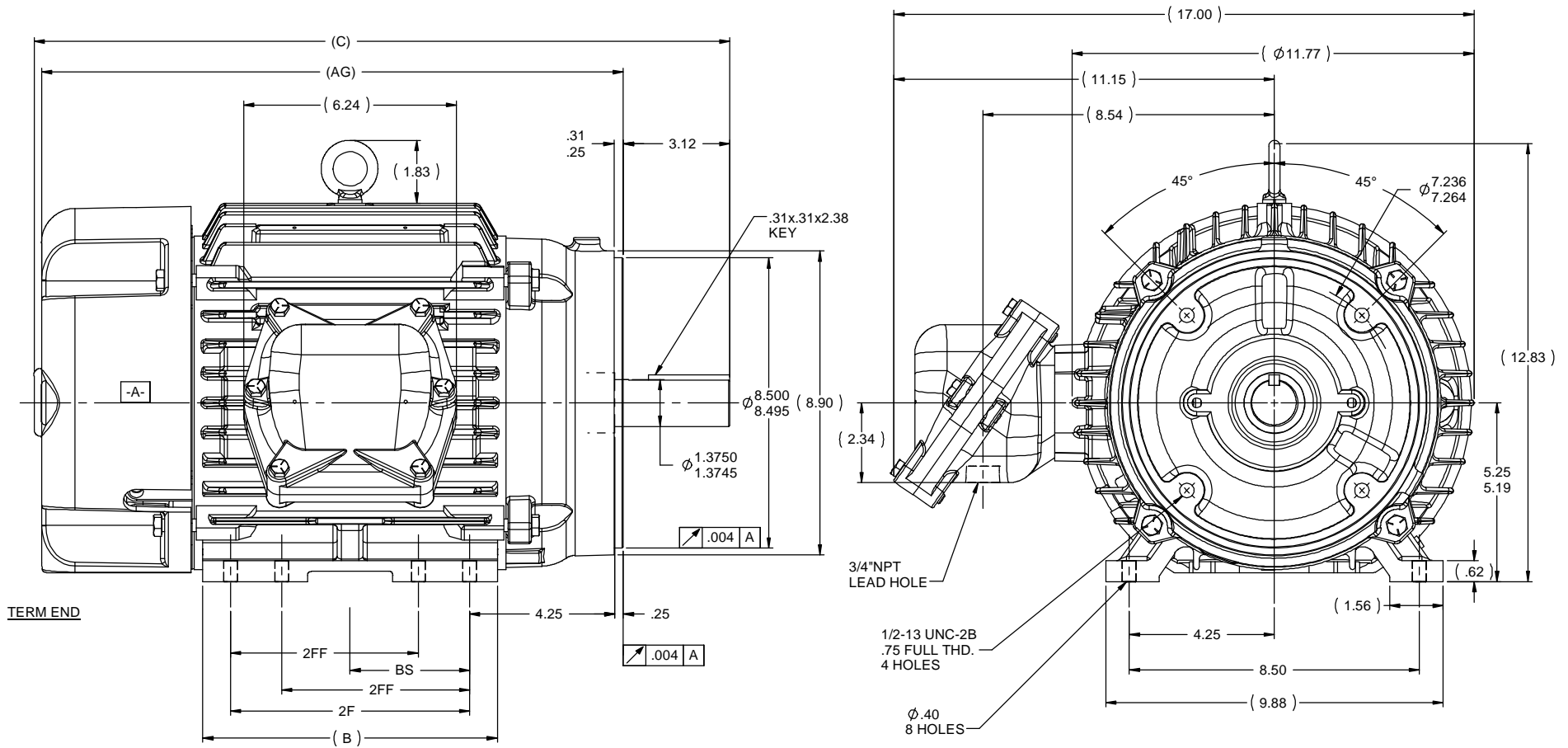

TERM END

NOTES:

1. CONDUIT BOX CAN BE ROTATED IN 90 ° STEPS.
2. CONDUIT BOX CAN BE MOUNTED IN OPPOSITE SIDE BY REMOVING BRACKETS AND TURNING FRAME 180 °. THIS MODIFICATION CAN BE PERFORMED ONLY BY THE ORIGINAL EQUIPMENT MANUFACTURER, OR BY A FACILITY THAT IS COVERED UNDER UNDERWRITERS LABORATORIES INC. CATEGORY PTKQ, TITLED "MOTOR AND GENERATORS, REBUILT FOR USE IN HAZARDOUS LOCATION".
3. NAMEPLATE TO BE READ FROM CONDUIT BOX SIDE OF MOTOR.

1212	213/215	23.45	11.76	10	7	5	20.11
912	213/215	20.45	8.63	7	5.5	3.5	17.11
DASH	FRAME	C	B	2F	2FF	BS	AG

		TOLERANCES UNLESS SPECIFIED		ELECTRIC MOTORS GEARMOTORS AND DRIVES		DRAWN PN 9/2/2010		
		DEC INCHES				CHK AK 9/2/2010		
		.X ±.1		TITLE OUTLINE		APPR		
		.XX ±.02		210.FR - EPFC		SCALE 1:4		
		.XXX ±.005		MATL		REF 037660		
01	UPDATED PER IS12-0462	GR 2/14/2012	PN	XXXX ±.0005	FMF			
NO	REVISION	BY & DATE	CHK	ANG ±730°	PREV			
THIS DRAWING IN DESIGN AND DETAIL IS OUR PROPERTY AND MUST NOT BE USED EXCEPT IN CONNECTION WITH OUR WORK. ALL RIGHTS OF DESIGN AND INVENTION ARE RESERVED. THIS IS AN ELECTRONICALLY GENERATED DOCUMENT - DO NOT SCALE THIS PRINT				RFP	CAD FILE	SIZE	DRAWING NO	
				DIST	037702LE	B	037702LE	
							REV	01

THREE PHASE
DUAL VOLTAGE MOTOR

HIGH VOLTAGE

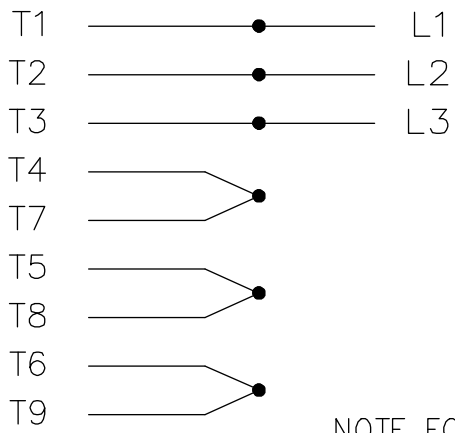

NOTE FOR FACTORY USE ONLY:
 TO SURGE TEST FOR COMMON CONNECT:
 HIGH VOLT: CONNECT P1 TO T1
 THEN P2 TO L1
 LOW VOLT: CONNECT P1 TO T1 & T7,
 THEN P2 TO L1

LOW VOLTAGE

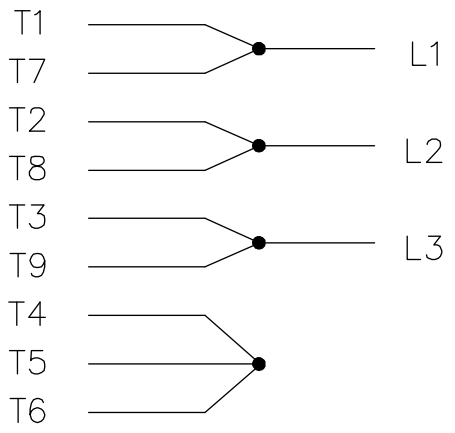

THREMO-PROTECTORS
CONNECTED IN SERIES.

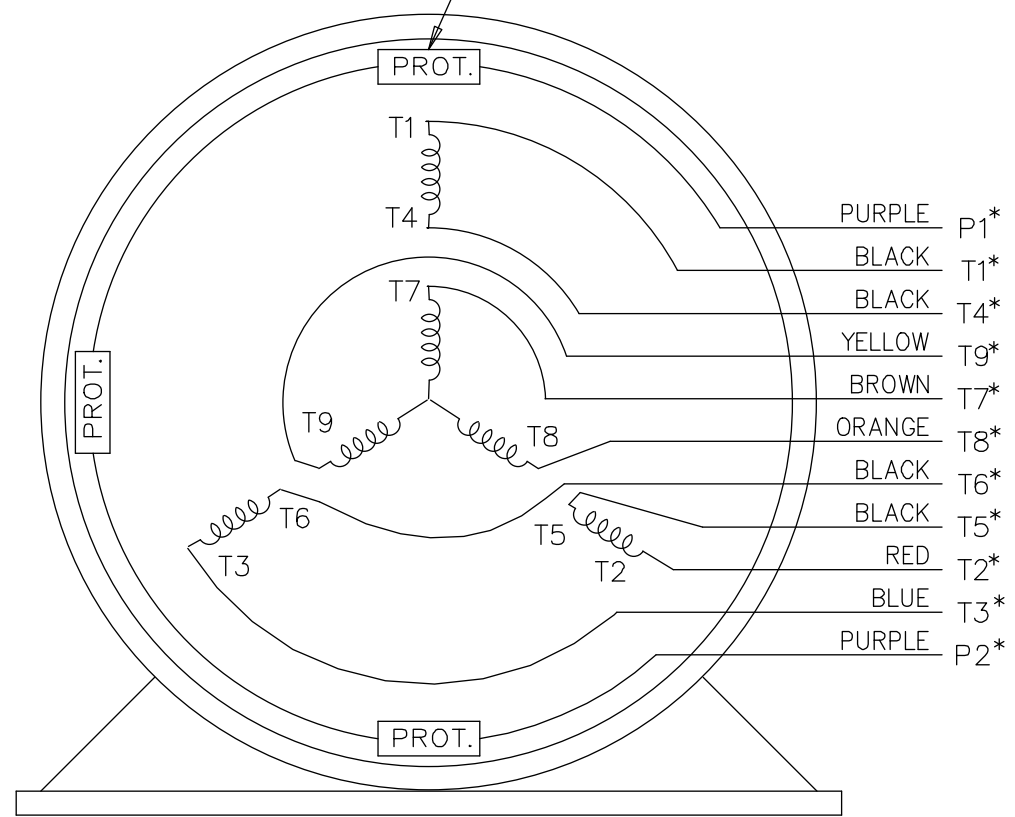

VIEW OF TERMINAL END

* USE LEADS AS PER PLANT STANDARD IRRWSPECTIVE OF THEIR COLOUR.

				TOLERANCES UNLESS SPECIFIED		 ELECTRIC MOTORS GEARMOTORS AND DRIVES	DRAWN TJB 05-07-2002		
NO.	REVISION	BY & DATE	CHK	ANG	±		FINISH	CHK	ML
05	ADDED * NOTE PER ECN # 26921	UD 01-30-2013	JD	DEC.	INCHES				
04	ADDED COLORS TO "T & P" LEADS CN 40494	MSG 08-08-2006	ML	.X	±.1		APPD	TB 05-08-2002	
03	RE-ISSUE	NJS 04-21-2004	JET	.XX	±.02	TITLE CONNECTION DIAGRAM	SCALE	1=1	
02	REDRAWN	TAT 04-20-2004	ML	.XXX	±.005	3 PHASE - DUAL VOLTAGE MOTOR	REF		
01	NEW DRAWING CN 34708	TJB 05-08-2002	ML	.XXXX	±.0005	MAT'L.	FMF		
					±7'30"		PREV		
THIS DRAWING IN DESIGN AND DETAIL IS OUR PROPERTY AND MUST NOT BE USED EXCEPT IN CONNECTION WITH OUR WORK ALL RIGHTS OF DESIGN AND INVENTION ARE RESERVED THIS IS AN ELECTRONICALLY GENERATED DOCUMENT - DO NOT SCALE THIS PRINT				RFP	CAD FILE EE7308T_LE		SIZE	DRAWING NO. PAGE OF	REV.
				DIST	LB-WP-LE		A	EE7308T-LE	05



**1051 CHEYENNE AVE.
GRAFTON, WI 53024
PH. 262-377-8810**

CERTIFICATION DATA SHEET

CONN. DIAGRAM: A-EE7308T-LE

CATALOG #: 825074.00

OUTLINE: 037702LE-1212

MOUNTING: F1 ONLY

WINDING #: K215295 6

TYPICAL MOTOR PERFORMANCE DATA

HP	kW	SYNC. RPM	F.L. RPM	FRAME	ENCLOSURE	KVA CODE	DESIGN
10&7 1/2	7.50&5.60	3600	3535&2950	215TC	EPFC	H	B

PH	Hz	VOLTS	AMPS	START TYPE	DUTY	INSL	S.F.	AMB°C
3	60/50	230/460&190/380	23.6/11.8&21/10.5	LINE OR INVERTER	CONTINUOUS	F3	1.15/1.15	40

FULL LOAD EFF:	91.7&92	3/4 LOAD EFF:	92.4	1/2 LOAD EFF:	91.7	GTD. EFF		ELEC. TYPE	
FULL LOAD PF:	87&88.5	3/4 LOAD PF:	86	1/2 LOAD PF:	78.5	91		SQ CAGE INV RATED	

F.L. TORQUE	LOCKED ROTOR AMPS	L.R. TORQUE	B.D. TORQUE	F.L. RISE°C
14.9 LB-FT	160 / 80	30 LB-FT 201 %	46 LB-FT 309 %	50

SOUND PRESSURE @ 3 FT.	SOUND POWER	ROTOR WK^2	MAX. WK^2	SAFE STALL TIME	STARTS / HOUR	APPROX. MOTOR WGT
72 dBA	82 dBA	0.68 LB-FT^2	18 LB-FT^2	15 SEC.	2	230 LBS.

***** SUPPLEMENTAL INFORMATION *****

DE BRACKET TYPE	ODE BRACKET TYPE	MOUNT TYPE	ORIENTATION	SEVERE DUTY	HAZARDOUS LOCATION	DRIP COVER	SCREENS	PAINT
C-FACE	STANDARD	RIGID	HORIZONTAL	TRUE	EXP PROOF CL I GR C&D CL II GR F&G T3B	FALSE	NONE	BLUE - LEESON (ENAMEL)

BEARINGS		GREASE	SHAFT TYPE	SPECIAL DE	SPECIAL ODE	SHAFT MATERIAL	FRAME MATERIAL
DE	ODE						
BALL	BALL	POLYREX EM	T	NONE	NONE	1045 HOT ROLLED (C-204)	CAST IRON
309	208						

THERMO-PROTECTORS				THERMISTORS	CONTROL	SPACE HEATERS
THERMOSTATS	PROTECTORS	WDG RTDs	BRG RTDs			
TSTATS (N/C)	NOT	NONE	NONE	NONE	FALSE	NONE VOLTS

*
N
O
T
E

INVERTER TORQUE: CONSTANT 10:1
INV. HP SPEED RANGE: NONE
ENCODER: NONE NONE NONE NONE NONE PPR
BRAKE: NONE NONE NONE P/N NONE NONE NONE FT-LB NONE V NONE HZ

Data Sheet

Date: 1/29/2018

825074.00



Data @ 460 V

Motor Load Data

Load	0%	25%	50%	75%	100%	115%	125%	LR
Current (Amps)	3.5	4.5	6.5	9.0	11.8	13.0	14.0	80.0
Torque (ft-lb)	0.00	3.5	7.5	11.0	14.9	17.0	18.5	30.0
RPM	3600	3585	3570	3555	3535	3,530	3525	0
Efficiency (%)		88.0	91.7	92.4	91.7	91.7	91.7	
P.F. (%)	8.5	58.5	78.5	86.0	87.0	89.0	90.0	40.0

Motor Speed Data

	LR	Pull-Up	BD	Rated	Idle
Speed (RPM)	0	1800	3175	3535	3600
Current (Amps)	80.0	72.0	50.0	11.8	3.5
Torque (ft-lb)	30.0	27.0	46.0	14.9	0.00

Information Block				
HP	10.0			
Sync. RPM	3600			
Frame	215			
Enclosure	TEFC			
Construction	TFN			
Voltage	230/460#190/380 V			
Frequency	60 Hz			
Design	B			
LR Code letter	H			
Service Factor	1.15			
Temp Rise @ FL	50 °C			
Duty	CONT			
Ambient	40 °C			
Elevation	1,000 feet			
Rotor/Shaft wk ²	0.68 Lb-Ft ²			
Ref Wdg	K215295 NONE			
Sound Pressure @ 1M	72 dBA			
VFD Rating	CONSTANT 10:1			
Outline Dwg	037702LE-1212			
Conn. Diag	A-EE7308T-LE			
Additional Specifications:				
0				
0				
EQUIV CKT (OHMS / PHASE)				
R1	R2	X1	X2	Xm
0.5230	0.3980	1.8060	2.0620	72.1360

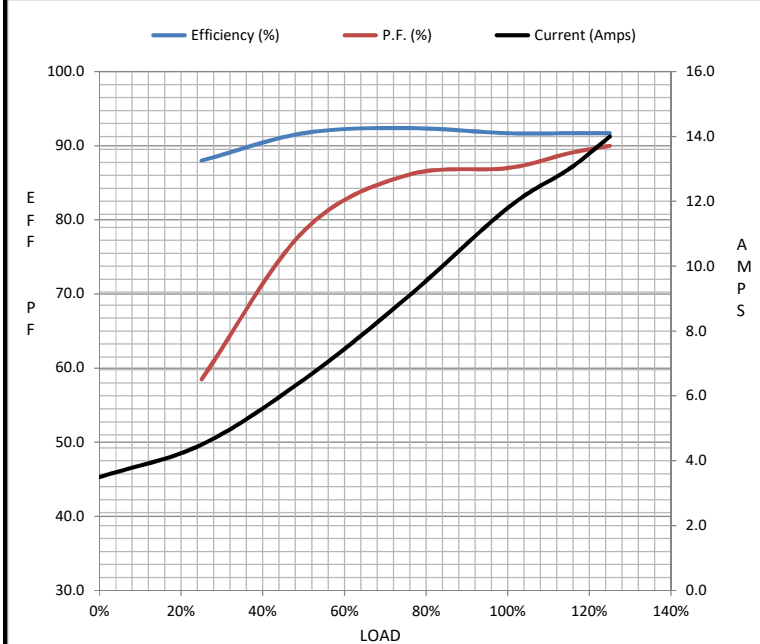

Speed - Torque Curve

