

PRODUCT INFORMATION PACKET



Model No: 824579.00
Catalog No: 824579.00
10 HP Definite Purpose HVAC HVAC/R Motor, 3 phase, 1200 RPM, 460 V, 256T Frame, TEAO
Definite Purpose Motors



Regal and Leeson are trademarks of Regal Rexnord Corporation or one of its affiliated companies.
©2021 Regal Rexnord Corporation, All Rights Reserved. MC017097E





Nameplate Specifications

Output HP	10 Hp	Output KW	7.5 kW
Frequency	60 Hz	Voltage	460 V
Current	12.8 A	Speed	1172 rpm
Service Factor	1.15	Phase	3
Efficiency	91 %	Power Factor	80
Duty	Continuous	Insulation Class	H
Design Code	B	KVA Code	H
Frame	256T	Enclosure	Totally Enclosed Air Over
Thermal Protection	No	Ambient Temperature	90 °C
Drive End Bearing Size	6309	Opp Drive End Bearing Size	6210
UL	Recognized	CSA	Y
CE	Y	IP Code	54
Number of Speeds	1		

Technical Specifications

Electrical Type	Squirrel Cage Inverter Rated	Starting Method	Line Or Inverter
Poles	6	Rotation	Reversible
Resistance Main	1.025 Ohms	Mounting	Rigid Base
Motor Orientation	Horizontal	Drive End Bearing	Ball / Heat Stabilized
Opp Drive End Bearing	Ball / Heat Stabilized	Frame Material	Cast Iron
Shaft Type	T	Overall Length	22.58 in
Frame Length	12.25 in	Shaft Diameter	1.625 in
Shaft Extension	4 in	Assembly/Box Mounting	F1/F2 CAPABLE
Inverter Load	VARIABLE 20:1		
Connection Drawing	A-EE7300T-LE	Outline Drawing	B-SS203092-1225

This is an uncontrolled document once printed or downloaded and is subject to change without notice. Date Created:10/07/2021

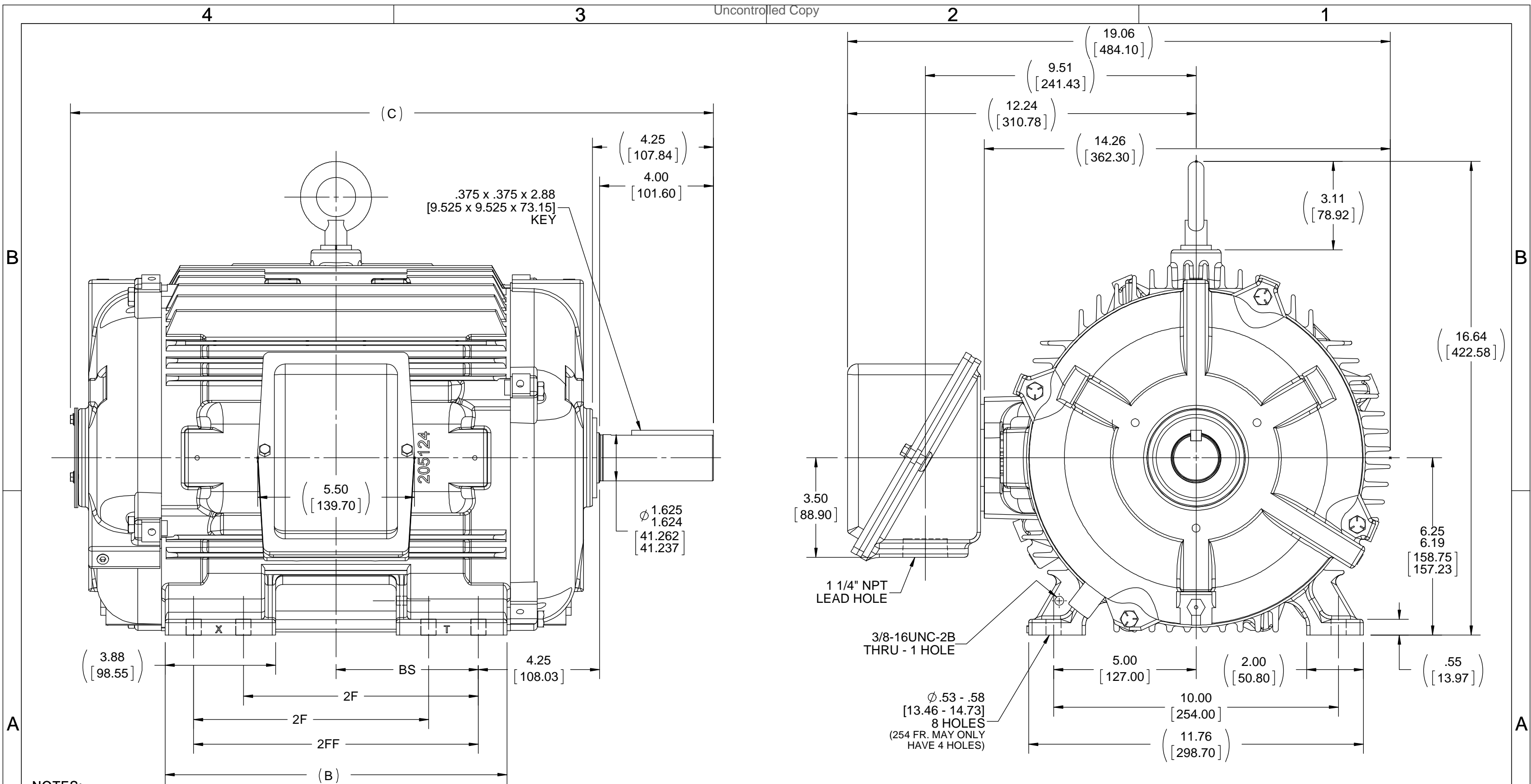

- NOTES:
1. CONDUIT BOX CAN BE ROTATED IN 90° STEPS.
 2. CONDUIT BOX CAN BE MOUNTED ON OPPOSITE SIDE BY REMOVING BRACKETS AND TURNING FRAME 180°.
 3. NAMEPLATES TO BE READ FROM CONDUIT BOX SIDE OF MOTOR.
 4. DIMENSIONS IN [] ARE IN MILLIMETERS.

DASH	FRAME	B	C	2F	2FF	BS
1050	254T	10.25 [260.35]	20.83 [529.08]	8.25 [209.55]	---	4.12 [104.65]
1225	254/256T	12.00 [304.80]	22.58 [573.53]	8.25 [209.55]	10.00 [254.00]	5.00 [127.00]

DRAWING REVISION D	REVISION BY JJB	DATE 09-20-2017
ECO ECO-0130892	APPROVED BY DJK	DATE 09-20-2017
ECO DESCRIPTION UPDATED FRAME		
<small>COPYRIGHT REGAL BELOIT AMERICA, INC. ALL RIGHTS RESERVED. PROPRIETARY AND CONFIDENTIAL INFORMATION - THIS DOCUMENT IS THE PROPERTY OF REGAL BELOIT AMERICA, INC. ("OWNER") AND CONTAINS OWNER'S PROPRIETARY INFORMATION. ANY PERSON, CORPORATION OR OTHER FIRM RECEIVING IT IS DEEMED, BY RECEIVING IT, TO AGREE THAT IT, AND/OR ANY PART OF IT, SHALL NOT BE DISCLOSED TO ANY PERSON, CORPORATION OR OTHER ENTITY, DUPLICATED, AND/OR USED, EXCEPT AS EXPRESSLY APPROVED IN WRITING IN ADVANCE BY OWNER. THIS DOCUMENT SHALL BE RETURNED TO OWNER UPON REQUEST. IT MAY BE SUBJECT TO CERTAIN RESTRICTIONS UNDER APPLICABLE EXPORT CONTROL LAWS AND REGULATIONS.</small>		

TOLERANCES UNLESS OTHERWISE SPECIFIED:

DEC.	INCH	mm	ANGLE
.X	± 0.1	[± 2.5]	$\pm 7' 30''$
.XX	± 0.03	[± 0.76]	
.XXX	± 0.005	[± 0.127]	
.XXXX	± 0.0005	[± 0.0127]	

REMOVE BURRS & BREAK SHARP EDGES: .003/.015 [.076/.381] X 45° CORNER FILLETS: R.02 [.51] MACHINED SURFACES: 200 INCH/mm 5.1 mm SHOWN IN [BRACKETS]

DRAWN BY BLR	DATE 04-26-1996
APPROVED BY BW	DATE 04-24-1996
REFERENCE	
THIRD ANGLE PROJECTION	

REGAL ™ Regal Beloit America, Inc.	
DESCRIPTION OUTLINE 250T FR. - TENV - BB - STD	
MATERIAL	PROCESS/FINISH
SIZE B	DRAWING NUMBER SS203092
	SHEET 1 OF 1

**THREE PHASE - SINGLE VOLTAGE MOTOR
CONDUIT BOX @ 'A'**

3 THERMO - PROTECTORS
CONNECTED IN SERIES

TO REVERSE ROTATION:
INTERCHANGE ANY TWO LINE
LEAD CONNECTIONS

NOTE FOR FACTORY USE ONLY:

TO SURGE TEST:

FOR 3 LEAD COMMON CONNECT:
CONNECT P1 TO T1, THEN P2 TO L1
FOR 6 LEAD COMMON CONNECT:
CONNECT P1 TO BOTH T1
THEN P2 TO L1

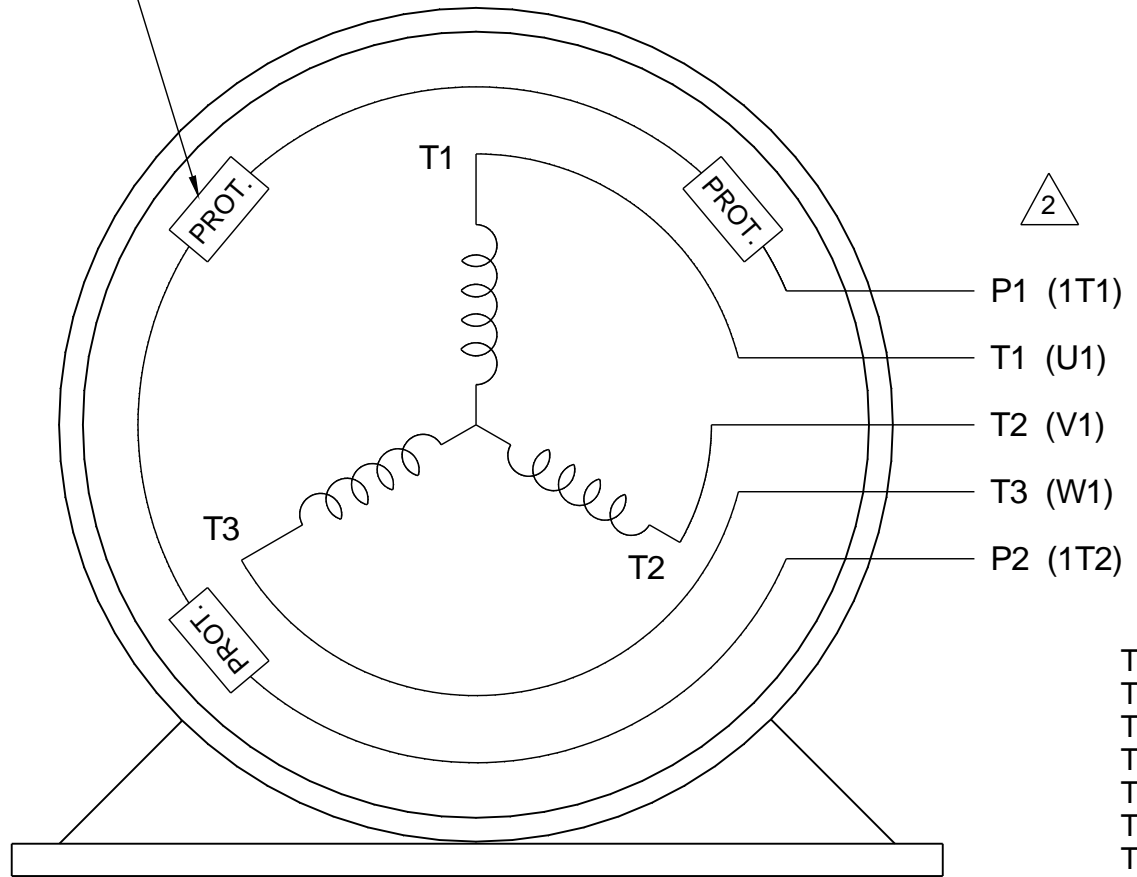

IF MOTOR HAS MULTIPLE T'S PER LEAD
CONNECT TOGETHER LIKE T'S

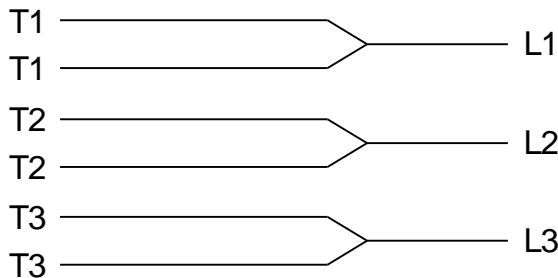

A-9806 DECAL

- T2BM
- T6AW
- T6AL
- T6Z
- T4EG
- T4BF
- T8A
- T6H
- T6A
- T4AX
- T4A
- T2A
- T2F

VIEW OF TERMINAL END

DRAWING REVISION E	REVISION BY MSG	DATE 10-19-2016
ECO ECO-0111093	APPROVED BY TB	DATE 10-19-2016
ECO DESCRIPTION REDRAWN - REVISED TEXT		
<small>COPYRIGHT REGAL BELOIT AMERICA, INC. ALL RIGHTS RESERVED. PROPRIETARY AND CONFIDENTIAL INFORMATION - THIS DOCUMENT IS THE PROPERTY OF REGAL BELOIT AMERICA, INC. ('OWNER') AND CONTAINS OWNER'S PROPRIETARY INFORMATION. ANY PERSON, CORPORATION OR OTHER FIRM RECEIVING IT IS DEEMED, BY RECEIVING IT, TO AGREE THAT IT, AND/OR ANY PART OF IT, SHALL NOT BE DISCLOSED TO ANY PERSON, CORPORATION OR OTHER ENTITY, DUPLICATED, AND/OR USED, EXCEPT AS EXPRESSLY APPROVED IN WRITING IN ADVANCE BY OWNER. THIS DOCUMENT SHALL BE RETURNED TO OWNER UPON REQUEST. IT MAY BE SUBJECT TO CERTAIN RESTRICTIONS UNDER APPLICABLE EXPORT CONTROL LAWS AND REGULATIONS.</small>		

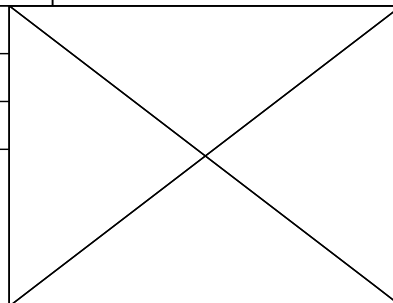

DRAWN BY NJS
DATE 05-15-2002
APPROVED BY ML
DATE 05-20-2002
REFERENCE
THIRD ANGLE PROJECTION

		ELECTRIC MOTORS GEARMOTORS AND DRIVES	
		DESCRIPTION CONNECTION DIAGRAM 3 PHASE - SINGLE VOLT - MOTOR WITH PROTECTORS	
MATERIAL		PROCESS/FINISH	
SIZE A	DRAWING NUMBER EE7300T-LE		SHEET 1 OF 1

P.O. BOX 8003
 WAUSAU, WI 54401-8003
 PH. 715-675-3311



DATA VOLTS: 460

CERTIFICATION DATA SHEET

CONN. DIAGRAM: A-EE7300T-LE
 OUTLINE: B-SS203092-1225
 WINDING: 2566110

CAT #: 824579.00

NONE 2

TYPICAL MOTOR PERFORMANCE DATA

HP	KW	SYNC RPM	FL RPM	FRAME	ENCLOSURE	TYPE	KVA CODE	DESIGN
10	7.5	1200	1172	256T	TEAO	TTN	H	B

PH	HZ	VOLTS	AMPS	START TYPE	DUTY	INSL	S.F.	AMB	ELEV.
3	60	460	12.8	LINE OR INVERTER	CONT	H	1.15	90	3300

F.L. EFF	91.0	3/4 LD EFF	91.0	1/2 LD EFF	90.2	GTD EFF	90.2	ELECT. TYPE
F.L. PF	80.0	3/4 LD PF	75.0	1/2 LD PF	64.0			SQ CAGE INV RATED

F.L. TORQUE	LR AMPS @ 460 V	L.R. TORQUE	B.D. TORQUE	F.L. RISE (°C)
44.8 LB-FT	81.0	95.0 LB-FT 212%	120 LB-FT 268%	0

PRESSURE @ 3	POWER	ROTOR WK²	MAX. LOAD WK²	SAFE STALL TIME	STARTS/HOUR	MOTOR WGT
999 dBA	1008 dBA	2.80 LB-FT²	150 LB-FT²	20 SEC.	2	340 LB.

*** SUPPLEMENTAL INFORMATION ***

DE BRACKET TYPE	ODE BRACKET TYPE	MOUNT TYPE	MOTOR ORIENTATION	SEVERE DUTY	HAZARDOUS LOCATION	DRIP COVER	SCREENS	PAINT
STANDARD	STANDARD	RIGID	HORIZONTAL	UM SEVERE	NONE	NO	NONE	BLUE (EPOXY)

BEARINGS		GREASE	SHAFT TYPE	SPECIAL DE	SPECIAL ODE	SHAFT MATERIAL	FRAME MATERIAL
DE	ODE						
6309	6210	DC 44M	T	NONE	NONE	1045 HOT ROLLED (C-204)	CAST IRON

THERMOSTATS	PROTECTORS	WDG RTD's	BRG RTD's	THERMISTORS	CONTROL	SPACE HEATERS
TSTATS CLH (N/C)	NOT	NONE	NONE	NONE	FALSE	NA

R1 (ohms/ph)	R2 (ohms/ph)	X1 (ohms/ph)	X2 (ohms/ph)	Xm (ohms/ph)	VIBRATION (in/sec)	FLOAT
0.676	0.525	2.317	2.295	44.446	0.080	ODE

* N O T E S *	INVERTER TORQUE: VARIABLE 20:1 INV. HP SPEED RANGE: NONE	
	ENCODER: NONE NONE NONE	
	NONE PPR	
	BRAKE: NONE NONE NONE	
	FT-LB: NA VOLTAGE: NONE HZ:	

DATE: 1/30/2018	UL: Y-(LEESON UL REC)
-----------------	-----------------------

Data Sheet

Date: 1/30/2018

824579.00



Data @ **460 V**

Motor Load Data

Load	0%	25%	50%	75%	100%	115%	125%	LR
Current (Amps)	5.8	6.5	8.2	10.2	12.8	14.5	15.8	81.0
Torque (ft-lb)	0.00	11.0	22.0	33.5	44.8	52.0	56.5	95.0
RPM	1200	1192	1188	1180	1172	1,168	1162	0
Efficiency (%)		85.5	90.2	91.0	91.0	90.2	89.5	
P.F. (%)	5.5	42.0	64.0	75.0	80.0	82.0	82.5	46.0

Motor Speed Data

	LR	Pull-Up	BD	Rated	Idle
Speed (RPM)	0	400	1050	1172	1200
Current (Amps)	81.0	78.0	48.0	12.8	5.8
Torque (ft-lb)	95.0	85.0	120	44.8	0.00

Information Block				
HP	10.0			
Sync. RPM	1200			
Frame	256			
Enclosure	TEAO			
Construction	TTN			
Voltage	460 V			
Frequency	60 Hz			
Design	B			
LR Code letter	H			
Service Factor	1.15			
Temp Rise @ FL	0 °C			
Duty	CONT			
Ambient	40 °C			
Elevation	1,000 feet			
Rotor/Shaft wk ²	2.80 Lb-Ft ²			
Ref Wdg	2566110 NONE			
Sound Pressure @ 1M	999 dBA			
VFD Rating	VARIABLE 20:1			
Outline Dwg	B-SS203092-1225			
Conn. Diag	A-EE7300T-LE			
Additional Specifications:				
0				
0				
EQUIV CKT (OHMS / PHASE)				
R1	R2	X1	X2	Xm
0.6760	0.5250	2.3170	2.2950	44.4460

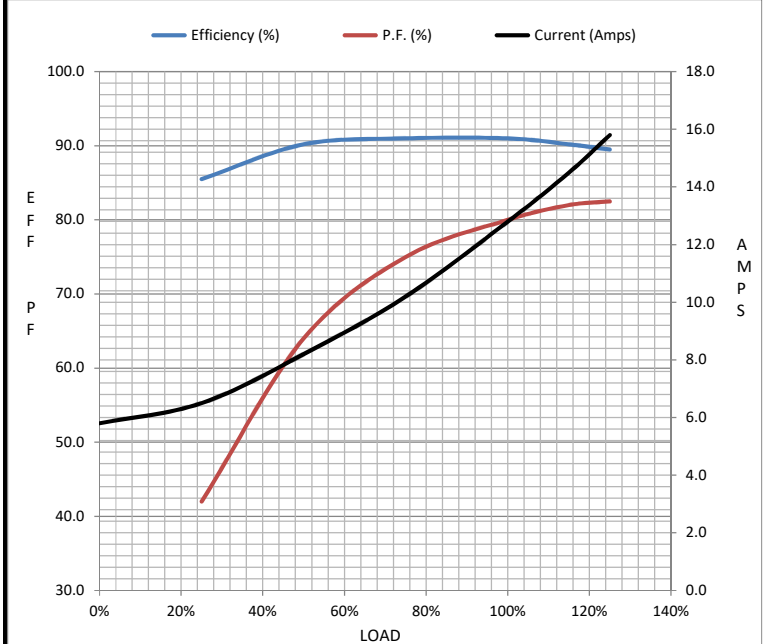

Speed - Torque Curve

