

# PRODUCT INFORMATION PACKET



Model No: 824570.00

Catalog No: 824570.00

Severe Duty Motor, 250 & 200 HP, 3 Ph, 60 & 50 Hz, 460 & 380 V, 1200 & 1000 RPM, 447/449TV Frame,  
TEAO



Regal and Leeson are trademarks of Regal Rexnord Corporation or one of its affiliated companies.

©2023 Regal Rexnord Corporation, All Rights Reserved. MC017097E





### Nameplate Specifications

Phase	<b>3</b>	Output HP	<b>250 &amp; 200 Hp</b>
Output KW	<b>187.0 &amp; 149.0 kW</b>	Voltage	<b>460 &amp; 380 V</b>
Speed	<b>1190 &amp; 990 rpm</b>	Service Factor	<b>1.15 &amp; 1.0</b>
Frame	<b>447/449TV</b>	Enclosure	<b>Totally Enclosed Air Over</b>
Thermal Protection	<b>Thermostat</b>	Efficiency	<b>95.8 &amp; 95.8 %</b>
Ambient Temperature	<b>40 °C</b>	Frequency	<b>60 &amp; 50 Hz</b>
Current	<b>300 &amp; 285 A</b>	Power Factor	<b>81</b>
Duty	<b>Continuous</b>	Insulation Class	<b>F</b>
Design Code	<b>B</b>	KVA Code	<b>G</b>
Drive End Bearing Size	<b>6319</b>	Opp Drive End Bearing Size	<b>6318</b>
UL	<b>Recognized</b>	CSA	<b>Y</b>
CE	<b>Y</b>	IP Code	<b>56</b>
Number of Speeds	<b>1</b>		

### Technical Specifications

Electrical Type	<b>Squirrel Cage Inverter Rated</b>	Starting Method	<b>Line Or Inverter</b>
Poles	<b>6</b>	Rotation	<b>Reversible</b>
Resistance Main	<b>.012 Ohms</b>	Mounting	<b>Rigid Base</b>
Motor Orientation	<b>Horizontal Or Up Or Down</b>	Drive End Bearing	<b>Ball</b>
Opp Drive End Bearing	<b>Ball</b>	Frame Material	<b>Cast Iron</b>
Shaft Type	<b>T</b>	Overall Length	<b>48.62 in</b>
Frame Length	<b>28.75 in</b>	Shaft Diameter	<b>3.375 in</b>
Shaft Extension	<b>8.75 in</b>	Assembly/Box Mounting	<b>F1/F2 CAPABLE</b>
Inverter Load	<b>VARIABLE 10:1</b>		
Connection Drawing	<b>EE7300S</b>	Outline Drawing	<b>SS555769LE-2875</b>

This is an uncontrolled document once printed or downloaded and is subject to change without notice. Date Created:06/21/2023

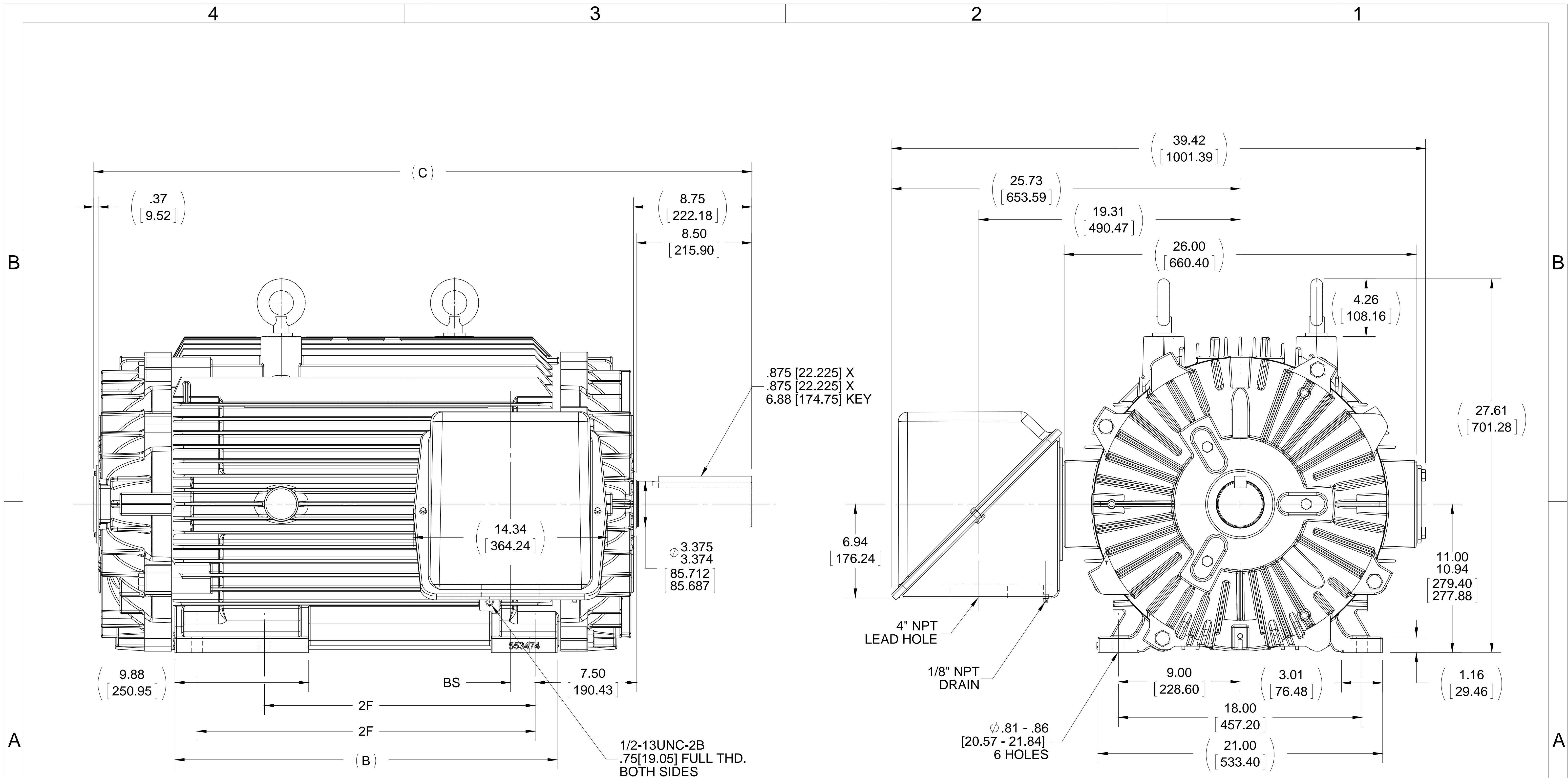

- NOTES:**  
 1. CONDUIT BOX CAN BE ROTATED IN 90° STEPS.  
 2. NAMEPLATES TO BE READ FROM CONDUIT BOX SIDE OF MOTOR.

DASH	FRAME	B	C	2F	2FF	BS
2875	447T	28.25 [717.55]	48.62 [1234.95]	20.00 [508.00]	---	1.84 [46.74]
2875	449T	28.25 [717.55]	48.62 [1234.95]	---	25.00 [635.00]	1.84 [46.74]

DRAWING REVISION D	REVISION BY AJW	DATE 05-08-2015
ECO ECO-0077392	APPROVED BY JHA	DATE 05-08-2015
ECO DESCRIPTION REMOVED "T" ON CBOX DRAIN		
<small>COPYRIGHT REGAL BELOIT AMERICA, INC. ALL RIGHTS RESERVED. PROPRIETARY AND CONFIDENTIAL INFORMATION - THIS DOCUMENT IS THE PROPERTY OF REGAL BELOIT AMERICA, INC. ("OWNER") AND CONTAINS OWNER'S PROPRIETARY INFORMATION. ANY PERSON, CORPORATION OR OTHER FIRM RECEIVING IT IS DEEMED, BY RECEIVING IT, TO AGREE THAT IT, AND/OR ANY PART OF IT, SHALL NOT BE DISCLOSED TO ANY PERSON, CORPORATION OR OTHER ENTITY, DUPLICATED, AND/OR USED, EXCEPT AS EXPRESSLY APPROVED IN WRITING IN ADVANCE BY OWNER. THIS DOCUMENT SHALL BE RETURNED TO OWNER UPON REQUEST. IT MAY BE SUBJECT TO CERTAIN RESTRICTIONS UNDER APPLICABLE EXPORT CONTROL LAWS AND REGULATIONS.</small>		

TOLERANCES UNLESS OTHERWISE SPECIFIED:  
 DEC. INCH mm ANGLE  
 .X ±0.1 [±2.5] ±7° 30"  
 .XX ±0.03 [±0.76]  
 .XXX ±0.005 [±0.127]  
 .XXXX ±0.0005 [±0.0127]  
 REMOVE BURRS & BREAK SHARP EDGES: .003/.015 [0.076/.381]  
 CORNER FILLETS: .02 [0.51]  
 MACHINED SURFACES: 200 INCH mm 5.1  
 mm SHOWN IN [BRACKETS]

DRAWN BY HV
DATE 05-30-2013
APPROVED BY DJK
DATE 05-30-2013
REFERENCE
THIRD ANGLE PROJECTION

**REGAL**™ Regal Beloit America, Inc.

DESCRIPTION  
**OUTLINE**  
4478/9T FR. - TEAO - T DRAIN

MATERIAL PROCESS/FINISH

SIZE **B** DRAWING NUMBER **SS555769LE** SHEET 1 OF 1

EE7300S

THREE PHASE – SINGLE VOLTAGE MOTOR

TO REVERSE ROTATION:  
INTERCHANGE ANY TWO LINE  
LEAD CONNECTIONS

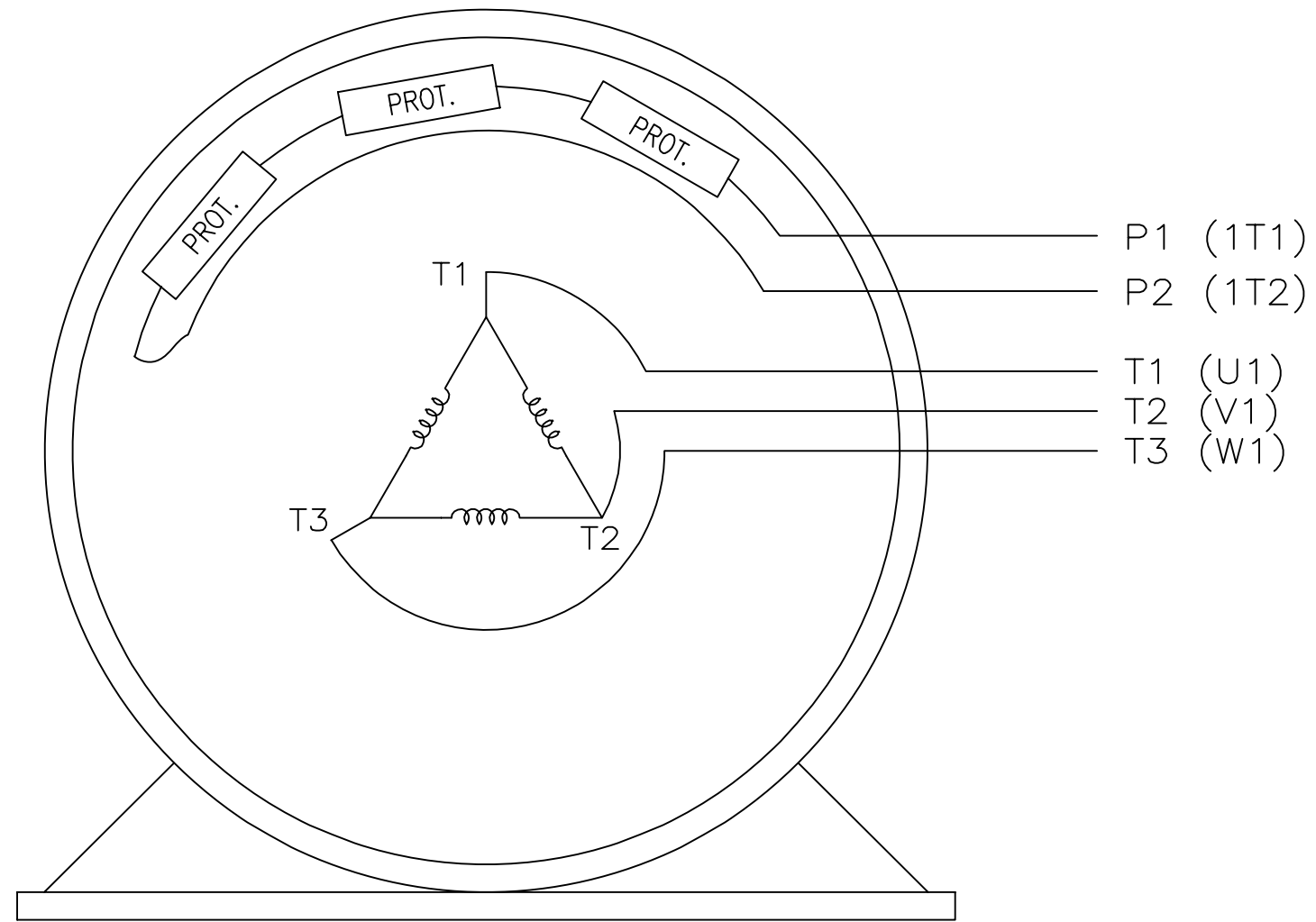

VIEW OF TERMINAL END

IF MOTOR HAS MULTIPLE  
T'S PER LEAD CONNECT  
TOGETHER LIKE T'S

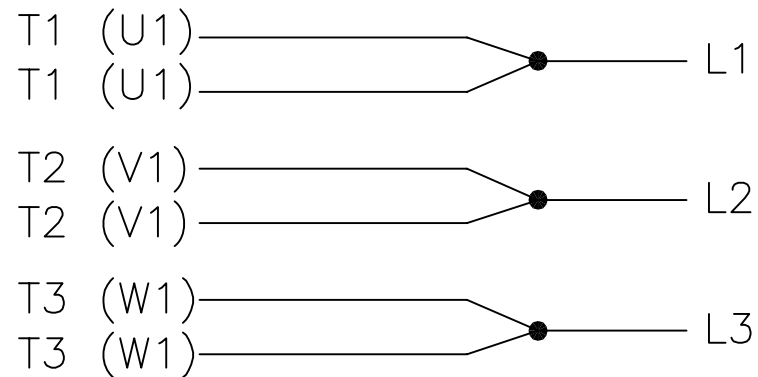

A-9806 DECAL

NO.	REVISION	BY & DATE	CHK	TOLERANCES UNLESS SPECIFIED			DRAWN	PAGE	OF	REV.		
				DEC.	INCHES							
F	UPDATED TITLE BLOCK	HV 02-27-2014	EWB	.X	±	-	KL	12-15-1999				
3	REMOVED "N.C." FROM PROT.'S MU61770	JJB 08-02-2010		.XX	±	-	CHK	DJK 12-15-1999				
2	ADDED IEC MARKINGS MU61770	KL 09-16-2004	EAB	.XXX	±	-	APPD	DJK 12-15-1999				
1	NEW DRAWING	KL 12-16-1999		.XXXX	±	-			SCALE	1=1		
									REF			
									FMP			
									PREV			
THIS DRAWING IN DESIGN AND DETAIL IS OUR PROPERTY AND MUST NOT BE USED EXCEPT IN CONNECTION WITH OUR WORK ALL RIGHTS OF DESIGN AND INVENTION ARE RESERVED THIS IS AN ELECTRONICALLY GENERATED DOCUMENT – DO NOT SCALE THIS PRINT				RFP	CAD FILE ee7300s			SIZE	DRAWING NO.	PAGE	OF	REV.
				DIST	WA-LB-SB			A	EE7300S			F



P.O. BOX 8003  
 WAUSAU, WI 54401-8003  
 PH. 715-675-3311



DATA VOLTS: 460

**CERTIFICATION DATA SHEET**

CONN. DIAGRAM: A-EE7300S  
 OUTLINE: B-SS555769LE-2875  
 WINDING: T449626

CAT #: 824570.00

R8 8

**TYPICAL MOTOR PERFORMANCE DATA**

HP	KW	SYNC RPM	FL RPM	FRAME	ENCLOSURE	TYPE	KVA CODE	DESIGN
250	187	1200	1190	447/449TV	TEAO	TTN	G	B

PH	HZ	VOLTS	AMPS	START TYPE	DUTY	INSL	S.F.	AMB	ELEV.
3	60/50	460#380	300&285	LINE OR INVERTER	CONT	F	1.15	40	3300

F.L. EFF	95.8	3/4 LD EFF	96.0	1/2 LD EFF	95.4	GTD EFF	95.4	ELECT. TYPE
F.L. PF	81.0	3/4 LD PF	79.0	1/2 LD PF	70.0	95.4		SQ CAGE INV RATED

F.L. TORQUE	LR AMPS @ 460 V	L.R. TORQUE	B.D. TORQUE	F.L. RISE (°C)
1,103 LB-FT	1,825	1,825 LB-FT 165%	2,825 LB-FT 256%	0

PRESSURE @ 3	POWER	ROTOR WK²	MAX. LOAD WK²	SAFE STALL TIME	STARTS/HOUR	MOTOR WGT
999 dBA	1008 dBA	138 LB-FT²	3600 LB-FT²	25 SEC.	2	3150 LB.

\*\*\* SUPPLEMENTAL INFORMATION \*\*\*

DE BRACKET TYPE	ODE BRACKET TYPE	MOUNT TYPE	MOTOR ORIENTATION	SEVERE DUTY	HAZARDOUS LOCATION	DRIP COVER	SCREENS	PAINT
STANDARD	STANDARD	RIGID	HORIZONTAL OR UP OR DOWN	SEVERE	NONE	NO	NONE	UR - LEESON (EPO)

BEARINGS		GREASE	SHAFT TYPE	SPECIAL DE	SPECIAL ODE	SHAFT MATERIAL	FRAME MATERIAL
DE	ODE						
BALL	BALL	POLYREX EM	T	NONE	NONE	1045 HOT ROLLED (C-204)	CAST IRON
6319	6318						

THERMOSTATS	PROTECTORS	WDG RTD's	BRG RTD's	THERMISTORS	CONTROL	SPACE HEATERS
TSTATS (N/C)	NOT	NONE	NONE	NONE	FALSE	NA

R1 (ohms/ph)	R2 (ohms/ph)	X1 (ohms/ph)	X2 (ohms/ph)	Xm (ohms/ph)	VIBRATION (in/sec)	FLOAT
0.008	0.008	0.096	0.129	2.177	0.080	ODE

* N O T E S *	INVERTER TORQUE: VARIABLE 10:1	
	INV. HP SPEED RANGE: NONE	
	ENCODER: NONE	
	NONE	
	NONE NONE PPR	

DATE: 1/29/2018	BRAKE: NONE	
	NONE NONE NONE	
	FT-LB: NA	HZ:
	VOLTAGE: NONE	
UL: Y-(LEESON UL REC)		

Data Sheet

Date: 1/29/2018

824570.00



Data @ **460 V**

Motor Load Data

Load	0%	25%	50%	75%	100%	115%	125%	LR
Current (Amps)	115	130	175	230	300	330	365	1,825
Torque (ft-lb)	0.00	275	550	825	1,103	1,245	1,385	1,825
RPM	1200	1196	1194	1192	1190	1,188	1186	0
Efficiency (%)		92.4	95.4	96.0	95.8	95.8	95.8	
P.F. (%)	3.5	49.0	70.0	79.0	81.0	82.5	83.0	23.0

Motor Speed Data

	LR	Pull-Up	BD	Rated	Idle
Speed (RPM)	0	600	1150	1190	1200
Current (Amps)	1,825	1,700	1,125	300	115
Torque (ft-lb)	1,825	1,700	2,825	1,103	0.00

Information Block				
HP	250.0			
Sync. RPM	1200			
Frame	449			
Enclosure	TEAO			
Construction	TTN			
Voltage	460#380 V			
Frequency	60 Hz			
Design	B			
LR Code letter	G			
Service Factor	1.15			
Temp Rise @ FL	0 °C			
Duty	CONT			
Ambient	40 °C			
Elevation	1,000 feet			
Rotor/Shaft wk <sup>2</sup>	138 Lb-Ft <sup>2</sup>			
Ref Wdg	T449626 R8			
Sound Pressure @ 1M	999 dBA			
VFD Rating	VARIABLE 10:1			
Outline Dwg	B-SS55769LE-2875			
Conn. Diag	A-EE7300S			
Additional Specifications:				
0				
0				
EQUIV CKT (OHMS / PHASE)				
R1	R2	X1	X2	Xm
0.0080	0.0080	0.0960	0.1290	2.1770

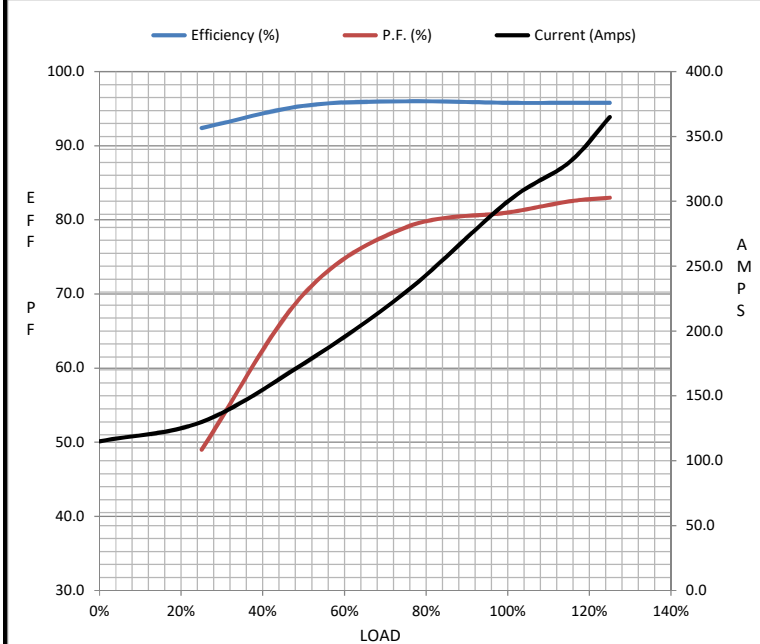

Speed - Torque Curve

