

PRODUCT INFORMATION PACKET



Model No: 824559.00

Catalog No: 824559.00

Severe Duty Motor, 20 & 16 HP, 3 Ph, 60 & 50 Hz, 230/460 & 190/380 V, 1200 & 1000 RPM, 286TV Frame,
TEAO



Regal and Leeson are trademarks of Regal Rexnord Corporation or one of its affiliated companies.

©2023 Regal Rexnord Corporation, All Rights Reserved. MC017097E





Nameplate Specifications

Phase	3	Output HP	20 & 16 Hp
Output KW	14.9 & 11.9 kW	Voltage	230/460 & 190/380 V
Speed	1175 & 975 rpm	Service Factor	1.15 & 1.0
Frame	286TV	Enclosure	Totally Enclosed Air Over
Thermal Protection	No Protection	Efficiency	91.7 & 91 %
Ambient Temperature	40 °C	Frequency	60 & 50 Hz
Current	53.5/26.8 & 54/27 A	Power Factor	76
Duty	Continuous	Insulation Class	F
Design Code	B	KVA Code	G
Drive End Bearing Size	6311	Opp Drive End Bearing Size	6210
UL	Recognized	CSA	Y
CE	Y	IP Code	56
Number of Speeds	1		

Technical Specifications

Electrical Type	Squirrel Cage Inverter Rated	Starting Method	Line Or Inverter
Poles	6	Rotation	Reversible
Resistance Main	.385 Ohms	Mounting	Rigid Base
Motor Orientation	Horizontal Or Up Or Down	Drive End Bearing	Ball
Opp Drive End Bearing	Ball	Frame Material	Cast Iron
Shaft Type	T	Overall Length	26.97 in
Frame Length	14.25 in	Shaft Diameter	1.875 in
Shaft Extension	4.62 in	Assembly/Box Mounting	F1/F2 CAPABLE
Inverter Load	CONSTANT 10:1		
Outline Drawing	SS312689-1425	Connection Drawing	EE7308

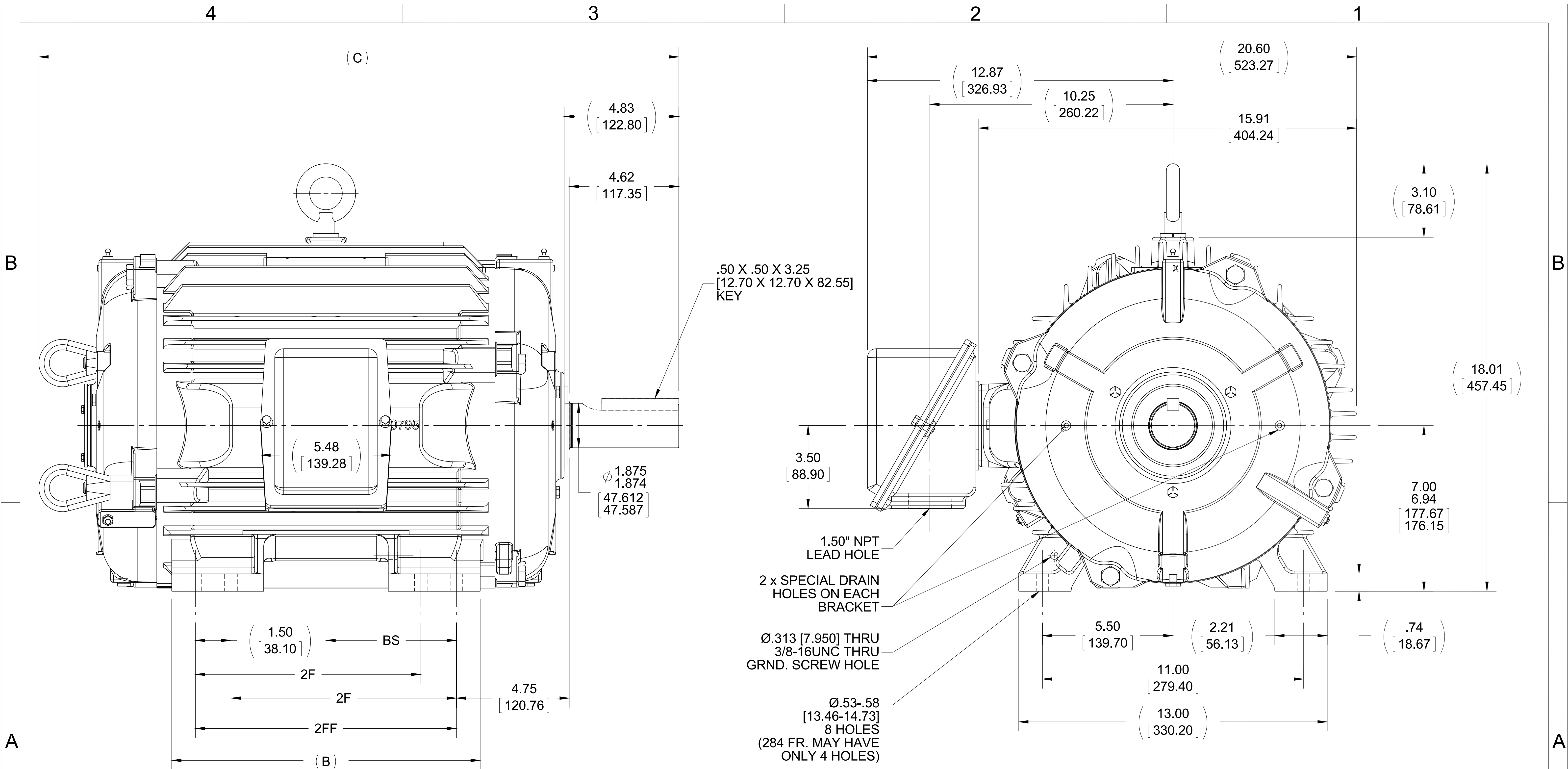

NOTES:

1. CONDUIT BOX CAN BE ROTATED IN 90° STEPS.
2. CONDUIT BOX CAN BE MOUNTED ON OPPOSITE SIDE BY REMOVING BRACKETS AND TURNING FRAME 180°.
3. NAMEPLATE TO BE READ FROM CONDUIT BOX SIDE OF MOTOR.

DASH	FRAME	B	C	BS	2F	2FF
1275	284T	12.50 [317.50]	25.47 [646.94]	4.75 [120.65]	---	9.50 [241.30]
1425	284/286T	13.00 [330.20]	26.97 [685.04]	5.50 [139.70]	9.50 [241.30]	11.00 [279.40]

DRAWING REVISION B	REVISION BY JWO	DATE 07-27-2015
ECO ECO-0081645	APPROVED BY TB	DATE 07-27-2015
ECO DESCRIPTION NMR-0084175, MU120012		
<small>COPYRIGHT REGAL BELOIT AMERICA, INC. ALL RIGHTS RESERVED. PROPRIETARY AND CONFIDENTIAL INFORMATION - THIS DOCUMENT IS THE PROPERTY OF REGAL BELOIT AMERICA, INC. ("OWNER") AND CONTAINS OWNER'S PROPRIETARY INFORMATION. ANY PERSON, CORPORATION OR OTHER FIRM RECEIVING IT IS DEEMED, BY RECEIVING IT, TO AGREE THAT IT, AND/OR ANY PART OF IT, SHALL NOT BE DISCLOSED TO ANY PERSON, CORPORATION OR OTHER ENTITY, DUPLICATED, AND/OR USED, EXCEPT AS EXPRESSLY APPROVED IN WRITING IN ADVANCE BY OWNER. THIS DOCUMENT SHALL BE RETURNED TO OWNER UPON REQUEST. IT MAY BE SUBJECT TO CERTAIN RESTRICTIONS UNDER APPLICABLE EXPORT CONTROL LAWS AND REGULATIONS.</small>		

TOLERANCES UNLESS OTHERWISE SPECIFIED:

DEC.	INCH	mm	ANGLE
.X	±0.1	[±2.5]	±7° 30"
.XX	±0.03	[±0.76]	
.XXX	±0.005	[±0.127]	
.XXXX	±0.0005	[±0.0127]	

REMOVE BURRS & BREAK SHARP EDGES: .003/.015 [0.076/.381]
CORNER FILLETS: .02 [.51]
MACHINED SURFACES: 200 INCH 5.1 mm SHOWN IN [BRACKETS]

DRAWN BY W. JOERGER
DATE 03-27-2015
APPROVED BY E. HEIL
DATE 03-27-2015
REFERENCE
THIRD ANGLE PROJECTION

REGAL ™ Regal Beloit America, Inc.	
DESCRIPTION OUTLINE 280T FR - TEAO / TENV - BB - STD - 12.50" LAM	
MATERIAL	PROCESS/FINISH
SIZE B	DRAWING NUMBER SS312689
SHEET 1 OF 1	



NO.	REVISION	BY & DATE	CHK	ANG	TOLERANCES UNLESS SPECIFIED		FINISH	DRAWN RM	ML	REV.	
					DEC.	INCHES					
5	CHG TO REGAL LOGO	SL 09/10/2015	AB					RM	11/20/1990		
4	REVISED IEC NOTATIONS	MSG 11/15/2011	CMN	.X	±.1			CHK	ML 11/21/1990		
3	ADDED IEC NOTATIONS... (U1), (V1) ETC. MU95194	MSG 5/10/2010	MJS	.XX	±.02			APPD	SAS 04/24/2003		
2	ADDED THE OPTIONAL CORD CONNECTION MU46318	RDH 04/24/2003	DRS	.XXX	±.005			SCALE	1=1		
1	REDRAWN	RM 11/20/1990		.XXXX	±.0005			REF			
					±7'30"			FMP			
THIS DRAWING IN DESIGN AND DETAIL IS OUR PROPERTY AND MUST NOT BE USED EXCEPT IN CONNECTION WITH OUR WORK ALL RIGHTS OF DESIGN AND INVENTION ARE RESERVED THIS IS AN ELECTRONICALLY GENERATED DOCUMENT - DO NOT SCALE THIS PRINT							RFP	CAD FILE ee7308	SIZE	DRAWING NO. PAGE OF	REV.
							DIST WP		A	EE7308	5



TITLE CONNECTION DIAGRAM
3Ø - DUAL VOLTAGE MOTOR

P.O. BOX 8003
 WAUSAU, WI 54401-8003
 PH. 715-675-3311



DATA VOLTS: 460

CERTIFICATION DATA SHEET

CONN. DIAGRAM: A-EE7308
 OUTLINE: B-SS312689-1425
 WINDING: 286654

CAT #: 824559.00

R7 8

TYPICAL MOTOR PERFORMANCE DATA

HP	KW	SYNC RPM	FL RPM	FRAME	ENCLOSURE	TYPE	KVA CODE	DESIGN
20	14.9	1200	1175	286TV	TEAO	TTN	G	B

PH	HZ	VOLTS	AMPS	START TYPE	DUTY	INSL	S.F.	AMB	ELEV.
3	60/50	230/460#190/380	53.5/26.8&54/27	LINE OR INVERTER	CONT	F	1.15	40	3300

F.L. EFF	91.7	3/4 LD EFF	91.7	1/2 LD EFF	91.7	GTD EFF	ELECT. TYPE
F.L. PF	76.0	3/4 LD PF	70.5	1/2 LD PF	59.5	91.0	SQ CAGE INV RATED

F.L. TORQUE	LR AMPS @ 460 V	L.R. TORQUE	B.D. TORQUE	F.L. RISE (°C)
89.0 LB-FT	145	157 LB-FT 176%	238 LB-FT 267%	0

PRESSURE @ 3	POWER	ROTOR WK²	MAX. LOAD WK²	SAFE STALL TIME	STARTS/HOUR	MOTOR WGT
999 dBA	1008 dBA	4.8 LB-FT²	350 LB-FT²	20 SEC.	2	540 LB.

*** SUPPLEMENTAL INFORMATION ***

DE BRACKET TYPE	ODE BRACKET TYPE	MOUNT TYPE	MOTOR ORIENTATION	SEVERE DUTY	HAZARDOUS LOCATION	DRIP COVER	SCREENS	PAINT
STANDARD	STANDARD	RIGID	ZONAL OR UP OR	UM SEVERE	NONE	NO	NONE	UE - LEESON (EPO)

BEARINGS		GREASE	SHAFT TYPE	SPECIAL DE	SPECIAL ODE	SHAFT MATERIAL	FRAME MATERIAL
DE	ODE						
BALL	BALL	POLYREX EM	T	NONE	NONE	1045 HOT ROLLED (C-204)	CAST IRON
6311	6210						

THERMOSTATS	PROTECTORS	WDG RTD's	BRG RTD's	THERMISTORS	CONTROL	SPACE HEATERS
NONE	NOT	NONE	NONE	NONE	FALSE	NA

R1 (ohms/ph)	R2 (ohms/ph)	X1 (ohms/ph)	X2 (ohms/ph)	Xm (ohms/ph)	VIBRATION (in/sec)	FLOAT
0.234	0.247	1.252	1.273	19.213	0.080	ODE

* N O T E S *	INVERTER TORQUE: CONSTANT 10:1 INV. HP SPEED RANGE: NONE					
	ENCODER: NONE					
	NONE					
	NONE					
	NONE PPR					

DATE: 1/29/2018	BRAKE: NONE					
	NONE					
	NONE					
FT-LB: NA						
VOLTAGE: NONE						
HZ:						
UL: Y-(LEESON UL REC)						

Data Sheet

Date: 1/29/2018

824559.00



Data @ **460 V**

Motor Load Data

Load	0%	25%	50%	75%	100%	115%	125%	LR
Current (Amps)	12.5	14.0	17.0	21.5	26.8	31.0	32.5	145
Torque (ft-lb)	0.00	22.0	44.0	66.5	89.0	103	112	157
RPM	1200	1195	1190	1180	1175	1,170	1167	0
Efficiency (%)		87.5	91.7	91.7	91.7	91.0	91.0	
P.F. (%)	20.5	38.5	59.5	70.5	76.0	78.0	79.0	36.0

Motor Speed Data

	LR	Pull-Up	BD	Rated	Idle
Speed (RPM)	0	600	1070	1175	1200
Current (Amps)	145	135	93.5	26.8	12.5
Torque (ft-lb)	157	152	238	89.0	0.00

Information Block				
HP	20.0			
Sync. RPM	1200			
Frame	286			
Enclosure	TEAO			
Construction	TTN			
Voltage	230/460#190/380 V			
Frequency	60 Hz			
Design	B			
LR Code letter	G			
Service Factor	1.15			
Temp Rise @ FL	0 °C			
Duty	CONT			
Ambient	40 °C			
Elevation	1,000 feet			
Rotor/Shaft wk ²	4.8 Lb-Ft ²			
Ref Wdg	286654 R7			
Sound Pressure @ 1M	999 dBA			
VFD Rating	CONSTANT 10:1			
Outline Dwg	B-SS312689-1425			
Conn. Diag	A-EE7308			
Additional Specifications:				
0				
0				
EQUIV CKT (OHMS / PHASE)				
R1	R2	X1	X2	Xm
0.2340	0.2470	1.2520	1.2730	19.2130

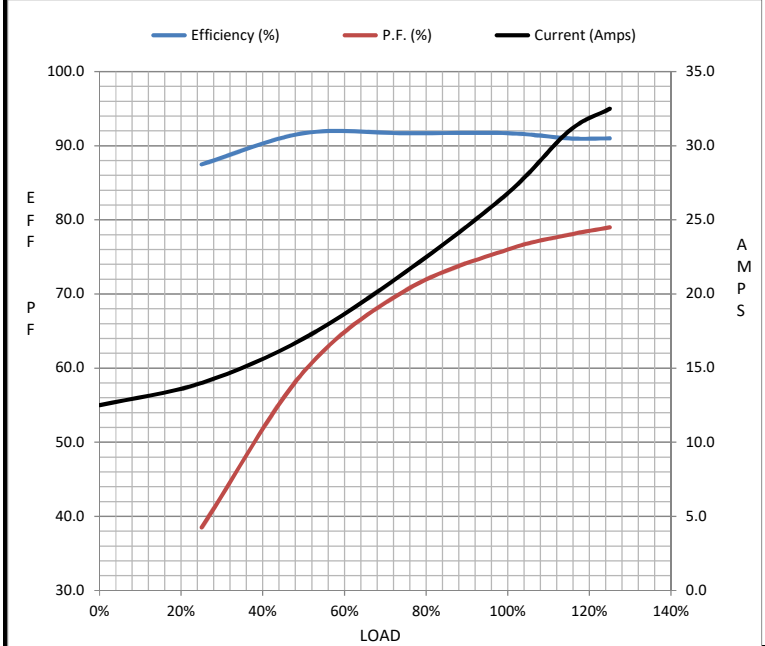

Speed - Torque Curve

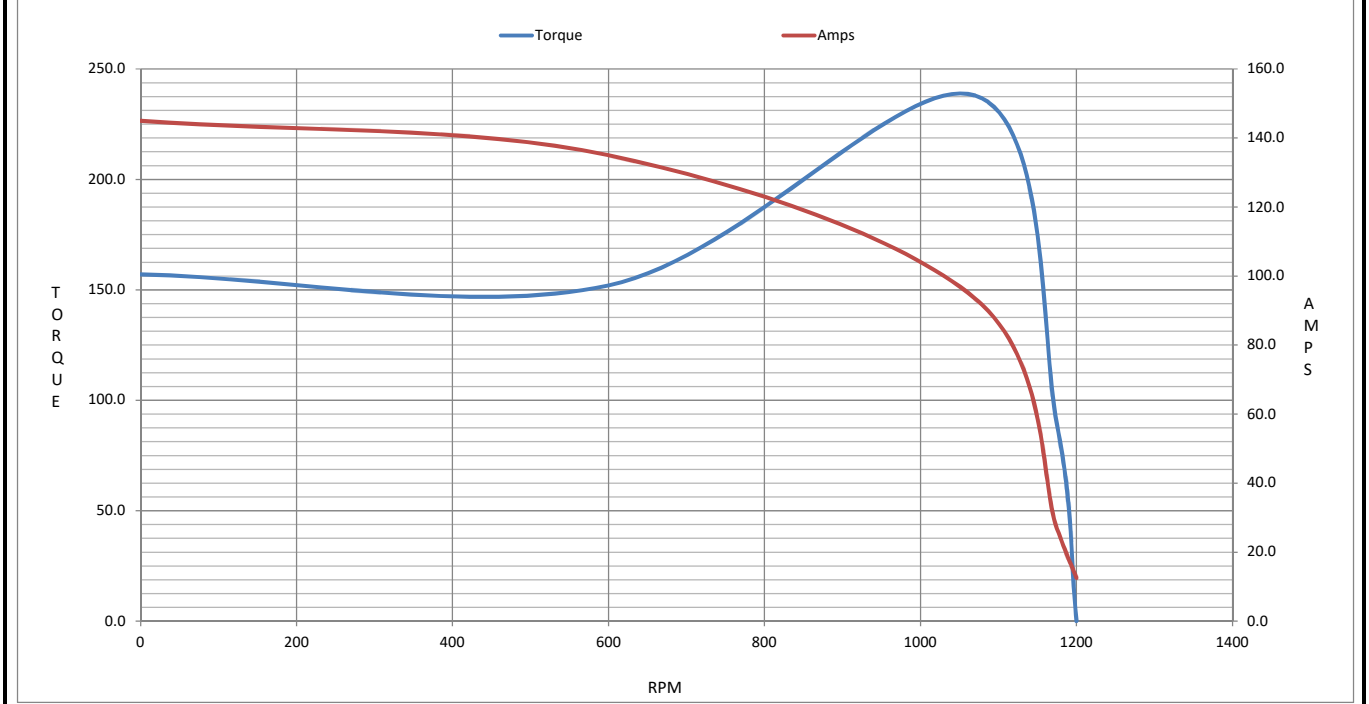

EC Declaration of Conformity

The undersigned representing
the manufacturer:

Regal Beloit America
100 East Randolph St.
Wausau, WI 54401

and the authorized representative
established within the Community:

Marathon Electric UK
6F Thistleton Road Ind. Estate
Market Overton
Oakham, Rutland LE15 7PP UK

are committed to providing customers with products that comply with applicable regulations and international protocols to which they are subject, including the requirements of the European Parliament Directive on the Harmonization of the laws relating to electrical equipment designed for use within certain voltage limits (2014/35/EU).

Regal Beloit America declares that the following product(s), to which this declaration relates, are in conformity with the relevant sections of the EC standards listed below.

This statement supersedes any statements previously issued pertaining to the product(s) listed below and is subject to change without notice.

Model No : 824559.00

(Model No. may contain prefix and/or suffix characters)

Catalog No : 824559.00

Rework No : N/A

Directives :

Low Voltage Directive 2014/35/EU

Harmonized Standards Used :

EN 60034-1: 2010 (IEC 60034-1: 2010)

EN 60034-5: 2001/A1:2007 (IEC 60034-5: 2000/A1:2006)

Authorized Representative:



Michael A. Logsdon
Vice President, Technology

Authorized Representative in the Community:



Julian Clark
Marketing Engineer

Created on 09/01/2022

CE 22