

# PRODUCT INFORMATION PACKET

rotor nl<sup>®</sup>

Model No: 6RN200L02E35U463021

Catalog No: 6RN200L02E35U46@3021

37.00 kW General Purpose Low Voltage IEC Motor IE3, 3 phase, 3000 rpm, D400/Y690V 50Hz,  
200L Frame B5, IC411



Regal and Rotor nl are trademarks of Regal Rexnord Corporation or one of its affiliated companies.  
©2023 Regal Rexnord Corporation, All Rights Reserved. MC017097E

RegalRexnord



### Nameplate Specifications

Output HP	<b>50 Hp</b>	Output KW	<b>37.0 kW</b>
Frequency	<b>50 Hz</b>	Voltage	<b>D400/Y690 V</b>
Current	<b>64.97 A</b>	Speed	<b>2955 rpm</b>
Service Factor	<b>1</b>	Phase	<b>3</b>
Efficiency	<b>93.7 %</b>	Power Factor	<b>0.88</b>
Duty	<b>S1</b>	Insulation Class	<b>F</b>
Frame	<b>200L</b>	Enclosure	<b>Totally Enclosed Fan Cooled</b>
Thermal Protection	<b>No Protection</b>	Ambient Temperature	<b>40 °C</b>
Drive End Bearing Size	<b>6312-2Z/C3WT (-40°C/+160°C)</b>	Opp Drive End Bearing Size	<b>6312-2Z/C3WT (-40°C/+160°C)</b>
UL	<b>No</b>	CSA	<b>Optional</b>
CE	<b>Yes</b>	IP Code	<b>IP55</b>
Number of Speeds	<b>1</b>	Efficiency Class	<b>IE3</b>

### Technical Specifications

Electrical Type	<b>Squirrel Cage</b>	Starting Method	<b>Direct On Line</b>
Poles	<b>2</b>	Rotation	<b>Clockwise Shaft End</b>
Mounting	<b>B5</b>	Motor Orientation	<b>Any</b>
Frame Material	<b>Cast iron</b>	Shaft Type	<b>Keyed</b>
Shaft Diameter	<b>55 mm</b>	Shaft Extension	<b>110 mm</b>
Outline Drawing	<b>6RN200L02E35U463021</b>		

This is an uncontrolled document once printed or downloaded and is subject to change without notice. Date Created:01/19/2023

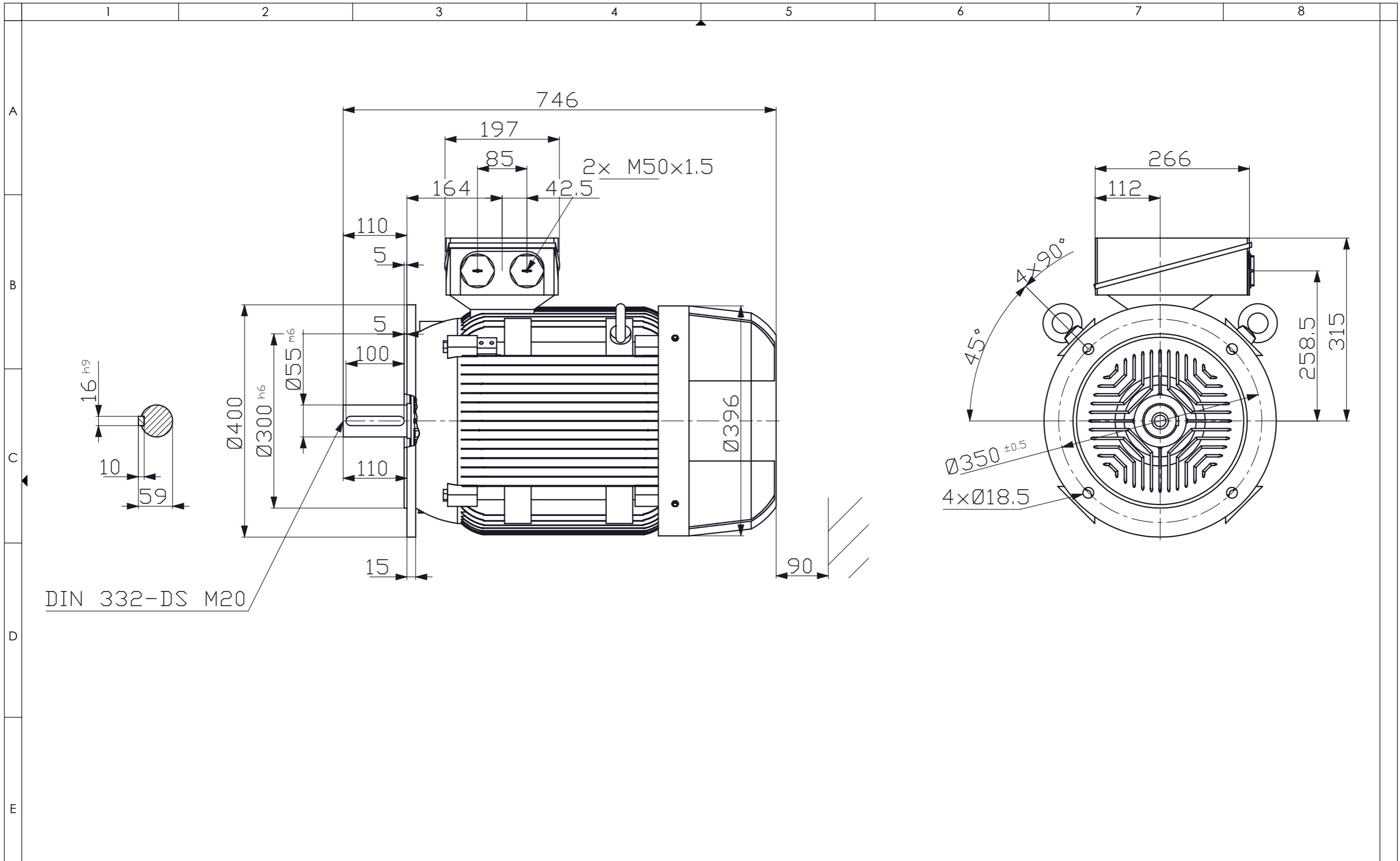

REVISIONS				
ZONE	REV.	DESCRIPTION	DATE	APPROVED

**REGAL**

**rotor**

Mors 2, P.O.box 45  
7150 AA Eibergen nl  
Tel:+31(0)545 464640  
E-mail:info@rotor.nl

MOTORTYPE: 6RN200L02E35  
MOUNTING: IM3041  
PROTECTION:  
COOLING: IC411  
REMARKS:  
DIMENSIONS: MM SCALE: 1:6

TITLE: Outline drawing  
SPECIAL:  
ART. NR.:  
REVISION:  
PAPER SIZE: A3 PAGE 1 OF 1

DRAWN:  
CHECKED:  
COMPLETE OR PARTIAL  
COPYING OR USE OF  
SPECIFICATIONS IS  
NOT ALLOWED WITHOUT  
OUR PERMISSION.  
SUBJECT TO ALTERATIONS

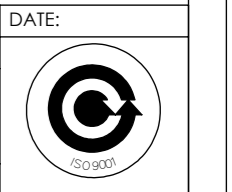

Datasheet



Mors 1-5, 7151 MX Eibergen NL  
 www.rotor.nl tel.: +31 545 464640  
 sales@rotor.nl tel.: +31 545 464646

**Model No.** 2-Pole cage motor 6RN 200L 37kW D400V 50Hz IM3021-FF350

U (V)	Δ/Y Conn	f [Hz]	P		I [A]	n [RPM]	T [Nm]	IE Class	% EFF at __ load			PF at __load			I <sub>A</sub> /I <sub>N</sub> [pu]	T <sub>A</sub> /T <sub>N</sub> [pu]	T <sub>R</sub> /T <sub>N</sub> [pu]
			[kW]	[hp]					FL	3/4FL	1/2FL	FL	3/4FL	1/2FL			
400	D	50	37	49,6	64,9	2955	119	IE3	93,9	94,1	93,7	0,88	0,85	0,79	7,00	2,39	3,18
690	Y		37,5														
460	D	60	41,5	55,63	63,2	3550	111	IE3	93,9	93,9	93,1	0,89	0,86	0,79	7,02	2,50	3,20

Motor type	<b>6RN200L02E35</b>
Enclosure	<b>Totally Enclosed Fan Cooling</b>
Frame Material	<b>Cast iron</b>
Frame size	<b>200L</b>
Duty	<b>S1</b>
Voltage	<b>400 V</b>
Frequency	<b>50 Hz</b>
Power output	<b>37 kW</b>
Insulation class	<b>F</b>
Ambient temperature	<b>-20 till 40 °C</b>
Temperature rise	<b>temp.rise acc. B (80K)</b>
Temperature rise winding	<b>65 K</b>
Temperature rise surface	<b>25 K</b>
Altitude above sea level	<b>1000 mtr</b>
Hazardous area classification	<b>Safe area</b>

Degree of protection	<b>IP55</b>
Mounting type	<b>IM3021-FF350</b>
Cooling method	<b>IC411</b>
Motor weight - approx.	<b>250 kg</b>
Gross weight - approx.	<b>260 kg</b>
Motor inertia	<b>0,1600 kgm<sup>2</sup></b>
Vibration level	<b>according IEC60034-14</b>
Noise level (pressure) acc 60034-9	<b>67 dB(A)</b>

Rotor type	<b>Cage motor</b>
Bearing type	<b>6312-2Z/C3WT</b>
Type of grease	<b>Unirex N3</b>
Phase resistance at 20°C	<b>0,1399 Ohm</b>
Country of origin	<b>CZ</b>

Voltage/Freq	Locked rotor Torque [nom] [%]	Starting current [% nom]	Pull-up Torque [% nom]	Breakdown Torque [% nom]	No-load Current [A]
@ D 400V 50Hz	239%	701%	210%	318%	20 A
@ D 460V 60Hz	250%	702%	210%	320%	18,5 A

**NOTE**

All performance values at rated voltage and frequency.  
 All performance parameters are subjected to standard tolerance as per IEC 60034-1  
 Voltage, Frequency are as per IEC60034-1  
 Technical data are subject to change. There may be discrepancies between calculated and name plate values.

Efficiency	Europe	Global IEC
Standards	EN-IEC: 60034-30	IEC: 60034-30

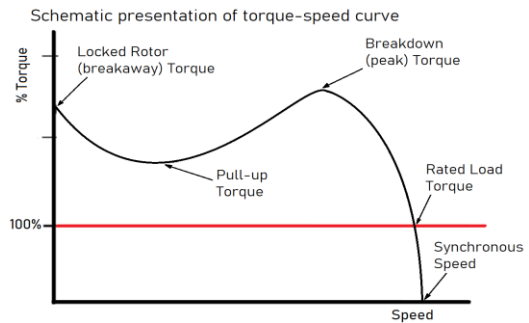

6RN200L02E35 2-pole 37,00kW D/Y 400/690V 50Hz S1 IC411 IE3



Torque versus Speed curve with variable frequency drive

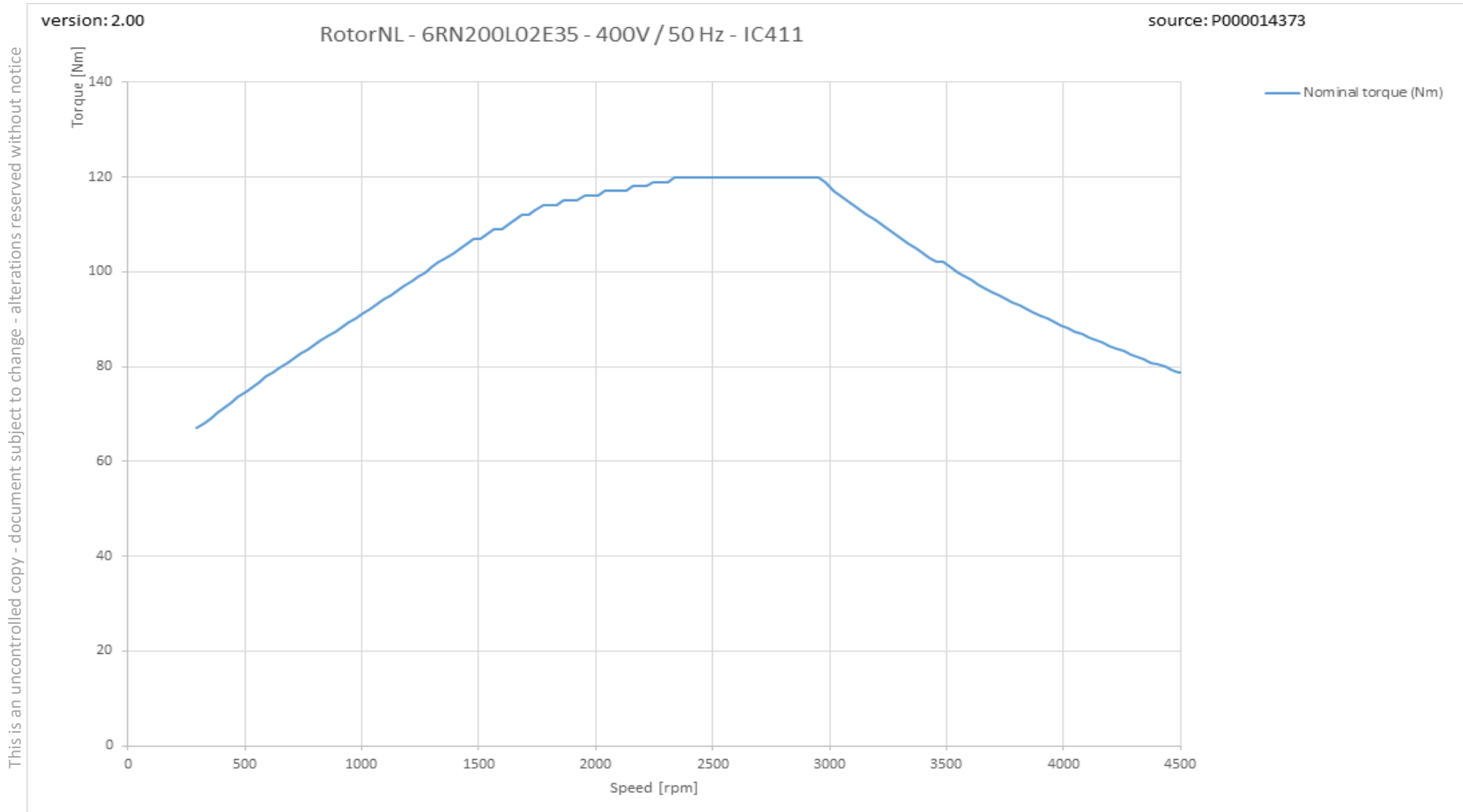

This is an uncontrolled copy - document subject to change - alterations reserved without notice

Therm\_VSD graph

This is an uncontrolled copy - document subject to change - alterations reserved without notice

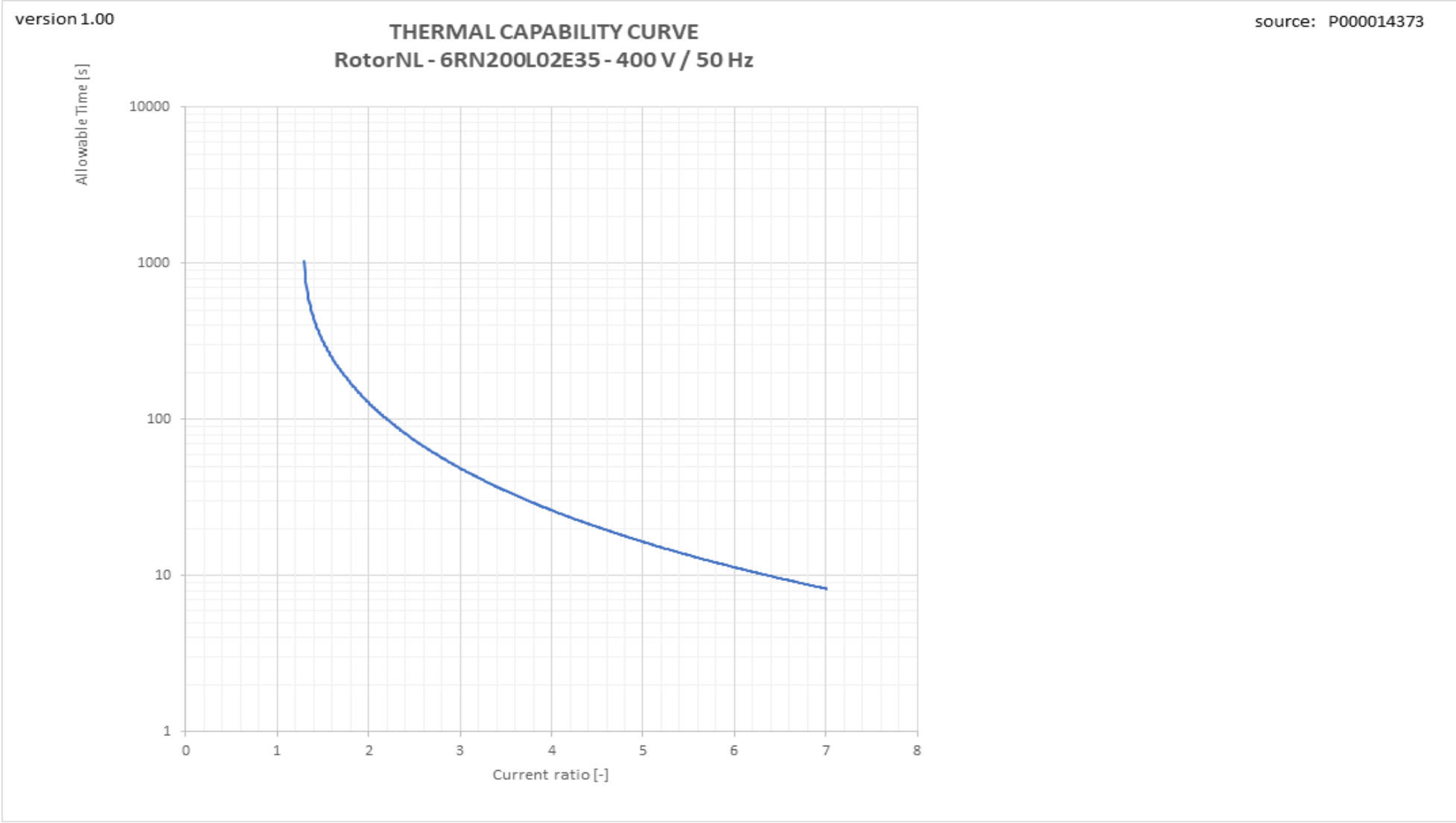

Tn graph

