

PRODUCT INFORMATION PACKET

Model No: 449TTFS8039

Catalog No: L469

Other Purpose Motor, 400 HP, 3 Ph, 60 Hz, 460 V, 1800 RPM, 447/449T Frame, TEFC

Regal and are trademarks of Regal Rexnord Corporation or one of its affiliated companies.
©2022 Regal Rexnord Corporation, All Rights Reserved. MC017097E



Nameplate Specifications

Output HP	400 Hp	Output KW	300.0 kW
Frequency	60 Hz	Voltage	460 V
Current	460.0 A	Speed	1785 rpm
Service Factor	1	Phase	3
Efficiency	95 %	Power Factor	85
Duty	Continuous	Insulation Class	H
Design Code	B	KVA Code	G
Frame	447/449T	Enclosure	Totally Enclosed Fan Cooled
Thermal Protection	No Protection	Ambient Temperature	40 °C
Drive End Bearing Size	NU319	Opp Drive End Bearing Size	6318
UL	Recognized	CSA	Y
CE	Y	IP Code	43
Number of Speeds	1		

Technical Specifications

Electrical Type	Squirrel Cage Induction Run	Starting Method	Across The Line
Poles	4	Rotation	Reversible
Resistance Main	0.0065 Ohms	Mounting	Rigid Base
Motor Orientation	Horizontal	Drive End Bearing	Roller
Opp Drive End Bearing	Ball	Frame Material	Cast Iron
Shaft Type	T	Overall Length	51.86 in
Frame Length	28.75 in	Shaft Diameter	3.380 in
Shaft Extension	8.75 in	Assembly/Box Mounting	F1/F2 Capable
Connection Drawing	A-EE7300	Outline Drawing	B-SS515635-2875

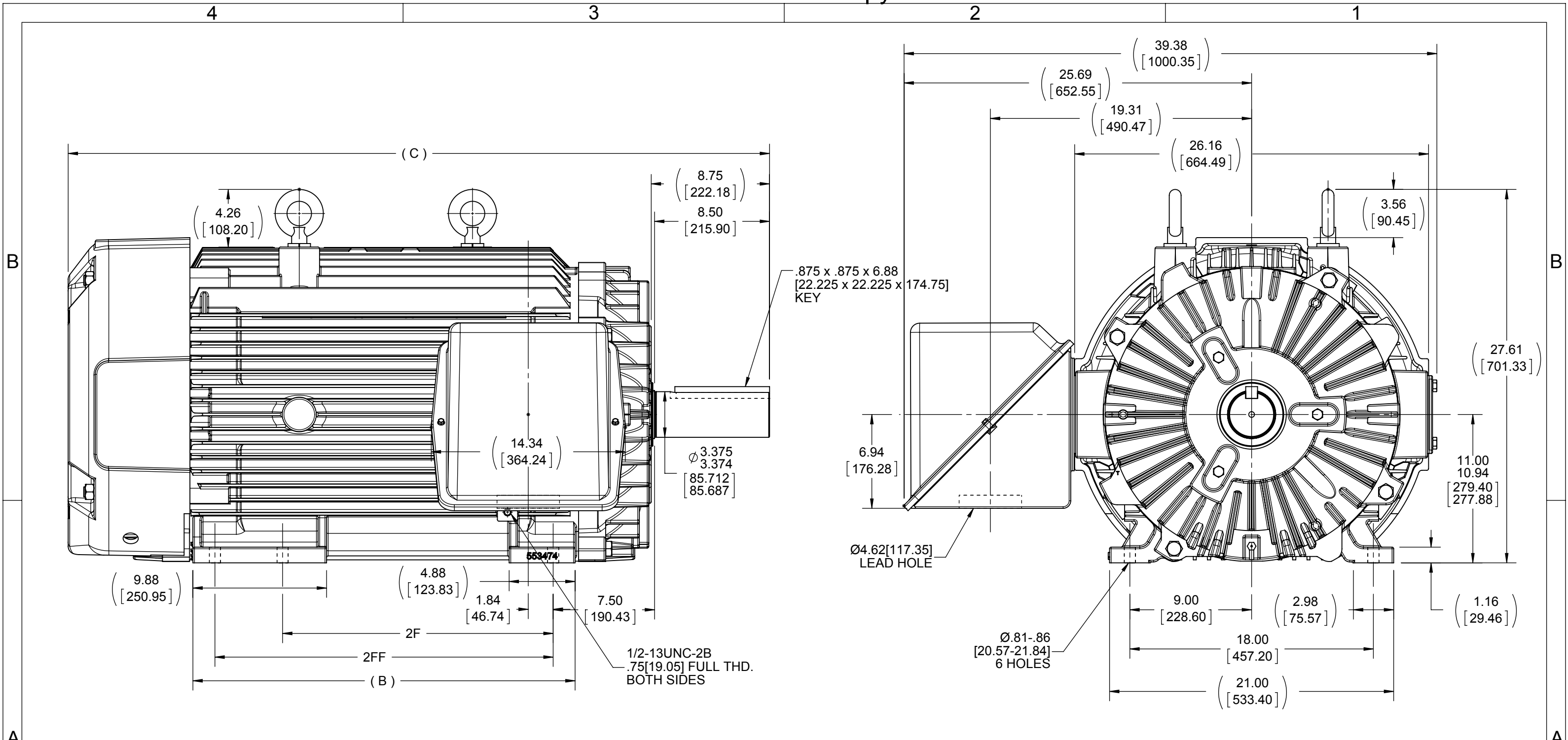

NOTES:

- 1- C'BOX CAN BE ROTATED IN 90° STEPS.
- 2- NAMEPLATES TO BE READ FROM C'BOX SIDE OF MOTOR.
- 3- C'BOX CAN BE MOUNTED IN F2 POSITION.

DASH	FRAME	B	C	2F	2FF
2875	447T	28.25 [717.55]	51.86 [1317.24]	20.00 [508.00]	---
2875	449T	28.25 [717.55]	51.86 [1317.24]	---	25.00 [635.00]

DRAWING REVISION D	REVISION BY CM	DATE 04-11-2014
ECO ECO-0049191	APPROVED BY DJK	DATE 04-11-2014
ECO DESCRIPTION UPDATE TO CURRENT STANDARDS		
<small>COPYRIGHT REGAL BELOIT AMERICA, INC. ALL RIGHTS RESERVED. PROPRIETARY AND CONFIDENTIAL INFORMATION - THIS DOCUMENT IS THE PROPERTY OF REGAL BELOIT AMERICA, INC. ("OWNER") AND CONTAINS OWNER'S PROPRIETARY INFORMATION. ANY PERSON, CORPORATION OR OTHER FIRM RECEIVING IT IS DEEMED, BY RECEIVING IT, TO AGREE THAT IT, AND/OR ANY PART OF IT, SHALL NOT BE DISCLOSED TO ANY PERSON, CORPORATION OR OTHER ENTITY, DUPLICATED, AND/OR USED, EXCEPT AS EXPRESSLY APPROVED IN WRITING IN ADVANCE BY OWNER. THIS DOCUMENT SHALL BE RETURNED TO OWNER UPON REQUEST. IT MAY BE SUBJECT TO CERTAIN RESTRICTIONS UNDER APPLICABLE EXPORT CONTROL LAWS AND REGULATIONS.</small>		

TOLERANCES UNLESS OTHERWISE SPECIFIED:

DEC.	INCH	mm	ANGLE
.X	±0.1	[±2.5]	±7° 30"
.XX	±0.03	[±0.76]	
.XXX	±0.005	[±0.127]	
.XXXX	±0.0005	[±0.0127]	

REMOVE BURRS & BREAK SHARP EDGES: .003/.015 [0.076/.381]
 CORNER FILLETS: .02 [0.51]
 MACHINED SURFACES: 200 INCH 5.1 mm
 mm SHOWN IN [BRACKETS]

DRAWN BY DT	DATE 06-04-1996
APPROVED BY JL	DATE 06-05-1996
PROCESS/FINISH	
THIRD ANGLE PROJECTION	

Regal Beloit America, Inc.	
DESCRIPTION OUTLINE 447-449T FR. - STD.	
MATERIAL	
SIZE B	DRAWING NUMBER SS515635
SHEET 1 OF 1	

THREE PHASE - SINGLE VOLTAGE
MOTOR - CONDUIT BOX @ 'A'

TERMINAL BLOCK WHEN SPECIFIED

TO REVERSE ROTATION:
INTERCHANGE ANY TWO LINE
LEAD CONNECTIONS

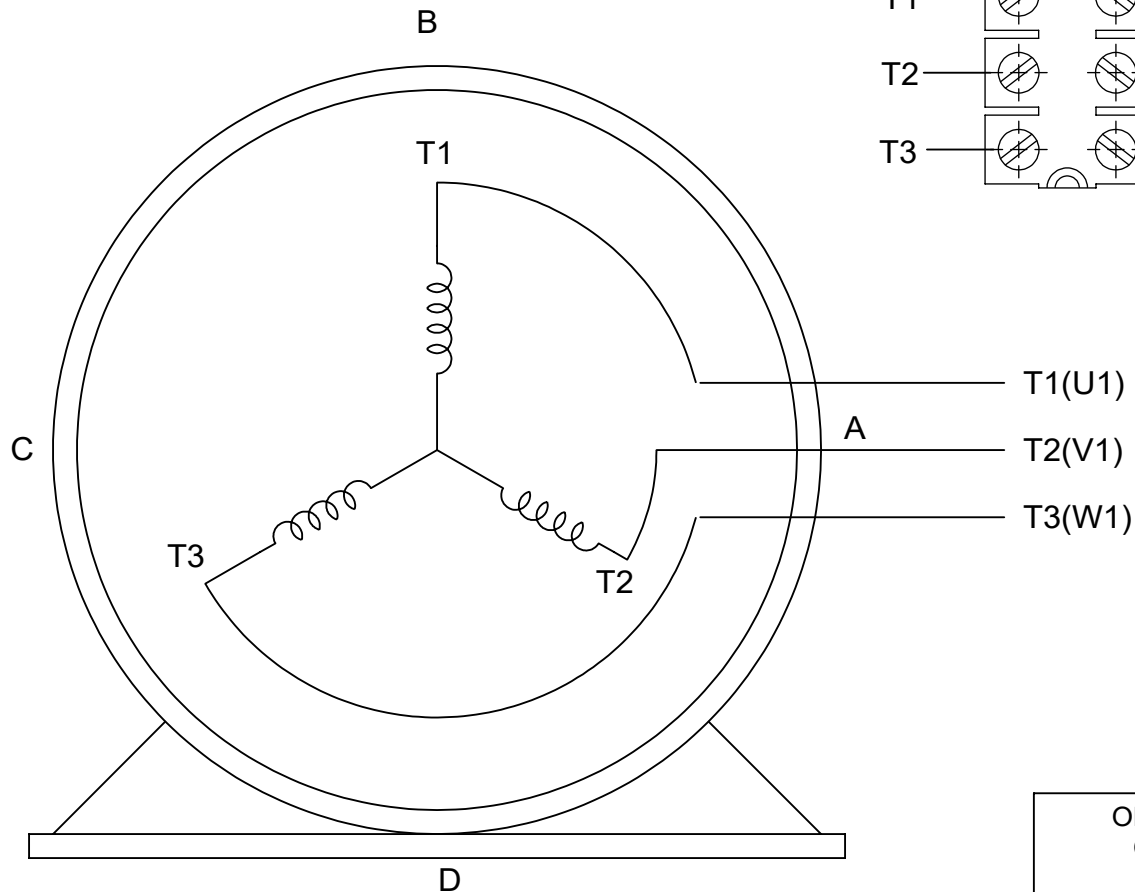

VIEW OF TERMINAL END

OPTIONAL CORD CONNECTION

L1	WHITE
L2	RED
L3	BLACK

DRAWING REVISION AC	REVISION BY BS	REV DATE/© DATE 26/07/2022
REQUEST NUMBER CR-0010402	APPROVED BY SN	DATE 26/07/2022
REQUEST NUMBER DESCRIPTION DRAWING UPDATED		
<small>COPYRIGHT (PER REVISION DATE) REGAL BELOIT AMERICA, INC. ALL RIGHTS RESERVED. PROPRIETARY AND CONFIDENTIAL INFORMATION - THIS DOCUMENT IS THE PROPERTY OF REGAL BELOIT AMERICA, INC. ("OWNER") AND CONTAINS OWNER'S PROPRIETARY INFORMATION. ANY PERSON, CORPORATION OR OTHER FIRM RECEIVING IT IS DEEMED, BY RECEIVING IT, TO AGREE THAT IT, AND/OR ANY PART OF IT, SHALL NOT BE DISCLOSED TO ANY PERSON, CORPORATION OR OTHER ENTITY, DUPLICATED, AND/OR USED, EXCEPT AS EXPRESSLY APPROVED IN WRITING IN ADVANCE BY OWNER. THIS DOCUMENT SHALL BE RETURNED TO OWNER UPON REQUEST. IT MAY BE SUBJECT TO CERTAIN RESTRICTIONS UNDER APPLICABLE EXPORT CONTROL LAWS AND REGULATIONS.</small>		

PRIMARY DIMENSIONS ARE INCH
mm DIMENSIONS IN [BRACKETS]
ARE FOR REFERENCE ONLY

DRAWN BY DA
DATE 03-26-1993
APPROVED BY TB
DATE 03-26-1993
REFERENCE
THIRD ANGLE PROJECTION

		Regal Beloit America, Inc.	
DESCRIPTION CONNECTION DIAGRAM EXTERNAL - SINGLE VOLTAGE - 3Ø MOTOR			
MATERIAL		PROCESS/FINISH	
SIZE A	DRAWING NUMBER EE7300		SHEET 1 OF 1