

PRODUCT INFORMATION PACKET

Model No: 449TTFS6582

Catalog No: E408

Severe Duty Motors, TEFC, 200 HP, 3 Ph, 60 Hz, 575 V, 1190 RPM, 449T Frame



Regal and are trademarks of Regal Rexnord Corporation or one of its affiliated companies.
©2022 Regal Rexnord Corporation, All Rights Reserved. MC017097E

Nameplate Specifications

Output HP	200 Hp	Output KW	149.0 kW
Frequency	60 Hz	Voltage	575 V
Current	192.0 A	Speed	1190 rpm
Service Factor	1.15	Phase	3
Efficiency	95.8 %	Power Factor	81
Duty	Continuous	Insulation Class	H
Design Code	B	KVA Code	G
Frame	449T	Enclosure	Totally Enclosed Fan Cooled
Thermal Protection	No Protection	Ambient Temperature	40 °C
Drive End Bearing Size	NU319	Opp Drive End Bearing Size	6318
UL	Recognized	CSA	Y
CE	Y	IP Code	54
Hazardous Location	DIVISION 2 T2B	Number of Speeds	1

Technical Specifications

Electrical Type	Squirrel Cage Inverter Rated	Starting Method	Line Or Inverter
Poles	6	Rotation	Reversible
Resistance Main	.016 Ohms	Mounting	Rigid Base
Motor Orientation	Horizontal	Drive End Bearing	Roller
Opp Drive End Bearing	Ball	Frame Material	Cast Iron
Shaft Type	T	Overall Length	51.84 in
Frame Length	28.75 in	Shaft Diameter	3.375 in
Shaft Extension	8.81 in	Assembly/Box Mounting	F1/F2 CAPABLE
Inverter Load	CONSTANT 2:1		
Connection Drawing	A-EE7300U	Outline Drawing	B-SS515631-2875

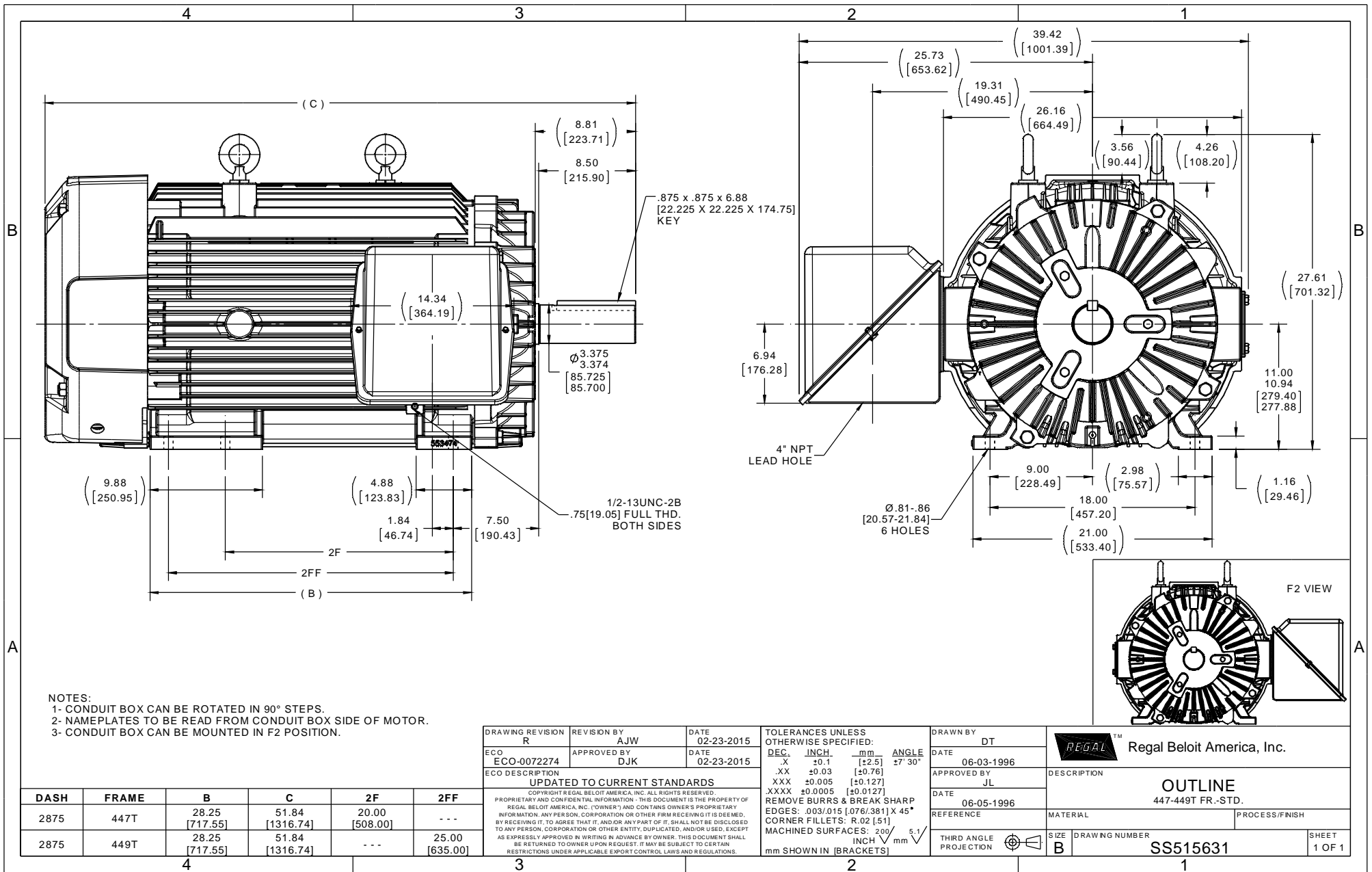

NOTES:
 1- CONDUIT BOX CAN BE ROTATED IN 90° STEPS.
 2- NAMEPLATES TO BE READ FROM CONDUIT BOX SIDE OF MOTOR.
 3- CONDUIT BOX CAN BE MOUNTED IN F2 POSITION.

DRAWING REVISION R	REVISION BY AJW	DATE 02-23-2015
ECO ECO-0072274	APPROVED BY DJK	DATE 02-23-2015
ECO DESCRIPTION UPDATED TO CURRENT STANDARDS COPYRIGHT REGAL BELOIT AMERICA, INC. ALL RIGHTS RESERVED. PROPRIETARY AND CONFIDENTIAL INFORMATION - THIS DOCUMENT IS THE PROPERTY OF REGAL BELOIT AMERICA, INC. (OWNER) AND CONTAINS OWNER'S PROPRIETARY INFORMATION. ANY PERSON, CORPORATION OR OTHER FIRM RECEIVING IT IS DEEMED, BY RECEIVING IT, TO AGREE THAT IT, AND/OR ANY PART OF IT, SHALL NOT BE DISCLOSED TO ANY PERSON, CORPORATION OR OTHER ENTITY, DUPLICATED, AND/OR USED, EXCEPT AS EXPRESSLY APPROVED IN WRITING IN ADVANCE BY OWNER. THIS DOCUMENT SHALL BE RETURNED TO OWNER UPON REQUEST. IT MAY BE SUBJECT TO CERTAIN RESTRICTIONS UNDER APPLICABLE EXPORT CONTROL LAWS AND REGULATIONS.		

TOLERANCES UNLESS OTHERWISE SPECIFIED:			
DEC.	INCH.	mm	ANGLE
.X	±0.1	[±2.5]	27° 30'
.XX	±0.03	[±0.76]	
.XXX	±0.005	[±0.127]	
.XXXX	±0.0005	[±0.0127]	
REMOVE BURRS & BREAK SHARP EDGES: .003/.015 [0.076/.381] X 45°			
CORNER FILLETS: R.02 [51]			
MACHINED SURFACES: 200 / INCH 5.1 / mm			
mm SHOWN IN [BRACKETS]			

DRAWN BY DT
DATE 06-03-1996
APPROVED BY JL
DATE 06-05-1996
REFERENCE
THIRD ANGLE PROJECTION

Regal Beloit America, Inc.	
DESCRIPTION OUTLINE 447-449T FR.-STD.	
MATERIAL	PROCESS/FINISH
SIZE B	DRAWING NUMBER SS515631
	SHEET 1 OF 1

DASH	FRAME	B	C	2F	2FF
2875	447T	28.25 [717.55]	51.84 [1316.74]	20.00 [508.00]	---
2875	449T	28.25 [717.55]	51.84 [1316.74]	---	25.00 [635.00]

IF MOTOR HAS 9 LEADS



IF MOTOR HAS 6 LEADS



A-9806 DECAL IF CALLED FOR

IF MOTOR HAS 12 LEADS



VIEW OF TERMINAL END

DRAWING REVISION L	REVISION BY AJW	DATE 05-04-2015	TOLERANCES UNLESS OTHERWISE SPECIFIED:	DRAWN BY DRS	Regal Beloit America, Inc.																					
ECO ECO-0077067	APPROVED BY EWH	DATE 05-05-2015	<table style="font-size: small; border-collapse: collapse;"> <tr> <td><u>DEC.</u></td> <td><u>INCH</u></td> <td><u>mm</u></td> <td><u>ANGLE</u></td> </tr> <tr> <td>.X</td> <td>±0.1</td> <td>[±2.5]</td> <td>±7' 30"</td> </tr> <tr> <td>.XX</td> <td>±0.02</td> <td>[±0.51]</td> <td></td> </tr> <tr> <td>.XXX</td> <td>±0.005</td> <td>[±0.127]</td> <td></td> </tr> <tr> <td>.XXXX</td> <td>±0.0005</td> <td>[±0.0127]</td> <td></td> </tr> </table>	<u>DEC.</u>			<u>INCH</u>	<u>mm</u>	<u>ANGLE</u>	.X	±0.1	[±2.5]	±7' 30"	.XX	±0.02	[±0.51]		.XXX	±0.005	[±0.127]		.XXXX	±0.0005	[±0.0127]		DATE 09-27-1996
<u>DEC.</u>	<u>INCH</u>	<u>mm</u>	<u>ANGLE</u>																							
.X	±0.1	[±2.5]	±7' 30"																							
.XX	±0.02	[±0.51]																								
.XXX	±0.005	[±0.127]																								
.XXXX	±0.0005	[±0.0127]																								
ECO DESCRIPTION UPDATED TO SOLIDWORKS <small>COPYRIGHT REGAL BELOIT AMERICA, INC. ALL RIGHTS RESERVED. PROPRIETARY AND CONFIDENTIAL INFORMATION - THIS DOCUMENT IS THE PROPERTY OF REGAL BELOIT AMERICA, INC. ("OWNER") AND CONTAINS OWNER'S PROPRIETARY INFORMATION. ANY PERSON, CORPORATION OR OTHER FIRM RECEIVING IT IS DEEMED, BY RECEIVING IT, TO AGREE THAT IT, AND/OR ANY PART OF IT, SHALL NOT BE DISCLOSED TO ANY PERSON, CORPORATION OR OTHER ENTITY, DUPLICATED, AND/OR USED, EXCEPT AS EXPRESSLY APPROVED IN WRITING IN ADVANCE BY OWNER. THIS DOCUMENT SHALL BE RETURNED TO OWNER UPON REQUEST. IT MAY BE SUBJECT TO CERTAIN RESTRICTIONS UNDER APPLICABLE EXPORT CONTROL LAWS AND REGULATIONS.</small>			APPROVED BY GK	DATE 09-30-1996	MATERIAL	PROCESS/FINISH																				
			REMOVE BURRS & BREAK SHARP EDGES: .003/.015 [.076/.381] X 45° CORNER FILLETS: R.02 [.51] MACHINED SURFACES: 200 $\sqrt{\text{INCH}}$ 5.1 $\sqrt{\text{mm}}$ mm SHOWN IN [BRACKETS]			REFERENCE	THIRD ANGLE PROJECTION	SIZE A	DRAWING NUMBER EE7300U	SHEET 1 OF 1																

CERTIFICATION DATA SHEET

Model#: 449TTFS6582 CV WINDING#: T449627 NONE 7
 CONN. DIAGRAM: A-EE7300U ASSEMBLY: F1/F2 CAPABLE
 OUTLINE: B-SS515631-2875

TYPICAL MOTOR PERFORMANCE DATA

HP	KW	SYNC. RPM	F.L. RPM	FRAME	ENCLOSURE	KVA CODE	DESIGN
200	149	1200	1190	447/449T	TEFC	G	B

PH	Hz	VOLTS	FL AMPS	START TYPE	DUTY	INSL	S.F	AMB°C	ELEVATION
3	60	575	192	LINE OR INVERTER	CONTINUOUS	H1	1.15	40	3300

FULL LOAD EFF: 95.8	3/4 LOAD EFF: 96	1/2 LOAD EFF: 95	GTD. EFF	ELEC. TYPE	NO LOAD AMPS
FULL LOAD PF: 81	3/4 LOAD PF: 78	1/2 LOAD PF: 70	95.4	SQ CAGE INV RATED	69.6

F.L. TORQUE	LOCKED ROTOR AMPS	L.R. TORQUE	B.D. TORQUE	F.L. RISE°C
883 LB-FT	1160	1325 LB-FT 150	2100 LB-FT 240	75

SOUND PRESSURE @ 3 FT.	SOUND POWER	ROTOR WK^2	MAX. WK^2	SAFE STALL TIME	STARTS /HOUR	APPROX. MOTOR WGT
72 dBA	82 dBA	115 LB-FT^2	2700 LB-FT^2	25 SEC.	2	2850 LBS.

***** SUPPLEMENTAL INFORMATION *****

DE BRACKET TYPE	ODE BRACKET TYPE	MOUNT TYPE	ORIENTATION	SEVERE DUTY	HAZARDOUS LOCATION	DRIP COVER	SCREENS	PAINT
STANDARD	STANDARD	RIGID	HORIZONTAL	PREMIUM SEVERE DUTY	DIVISION 2 T2B	FALSE	NONE	BLUE (EPOXY)

BEARINGS		GREASE	SHAFT TYPE	SPECIAL DE	SPECIAL ODE	SHAFT MATERIAL	FRAME MATERIAL
DE	OPE						
ROLLER	BALL	SHC-100/POLYREX	T	NONE	NONE	1045 HOT ROLLED (C-204)	CAST IRON
NU319	6318						

THERMO-PROTECTORS				THERMISTORS	CONTROL	SPACE /n HEATERS
THERMOSTATS	PROTECTORS	WDG RTDs	BRG RTDs			
NONE	NOT	NONE	NONE	NONE	FALSE	NONE VOLTS

If Inverter equals NONE, contact factory for further information

*
N
O
T
E
S
*

INVERTER TORQUE: CONSTANT 2:1
INV. HP SPEED RANGE: 1.5 X BASE SPEED
ENCODER: NONE
NONE NONE
NONE NONE PPR
BRAKE: NONE NONE
NONE P/N NONE
NONE NONE
NONE FT-LB NONE V NONE Hz

DATE: 06/21/2017 07:21:46 AM
 FORM 3531 REV.3 02/07/99
 ** Subject to change without notice.

Data Sheet

Date: 6/20/2017

Customer: _____

Attention: _____

Submitted by: FAREEDA DUDEKULA



449TFS6582

Submittal

Data @ 575 V

Motor Load Data

Load	0%	25%	50%	75%	100%	115%	125%	LR
Current (Amps)	69.6	84.0	113	152	192	216	240	1,160
Torque (ft-lb)	0.00	219	440	661	883	995	1,107	1,325
RPM	1200	1196	1194	1192	1190	1,188	1186	0
Efficiency (%)		93.0	95.0	96.0	95.8	95.8	95.4	
P.F. (%)	4.0	48.5	70.0	78.0	81.0	81.5	82.0	25.5

Motor Speed Data

	LR	Pull-Up	BD	Rated	Idle
Speed (RPM)	0	600	1125	1190	1200
Current (Amps)	1,160	1,080	660	192	69.6
Torque (ft-lb)	1,325	1,300	2,100	883	0.00

Information Block

HP	200.0			
Sync. RPM	1200			
Frame	449			
Enclosure	TEFC			
Construction	TFN			
Voltage	575 V			
Frequency	60 Hz			
Design	B			
LR Code letter	G			
Service Factor	1.15			
Temp Rise @ FL	75 °C			
Duty	CONT			
Ambient	40 °C			
Elevation	1,000 feet			
Rotor/Shaft wk ²	115 Lb-Ft ²			
Ref Wdg	T449627 NONE			
Sound Pressure @ 1M	72 dBA			
VFD Rating	CONSTANT 2:1			
Outline Dwg	B-SS515631-2875			
Conn. Diag	A-EE7300U			
Additional Specifications:				
0				
0				
EQUIV CKT (OHMS / PHASE)				
R1	R2	X1	X2	Xm
0.0160	0.0160	0.1960	0.2510	4.2820

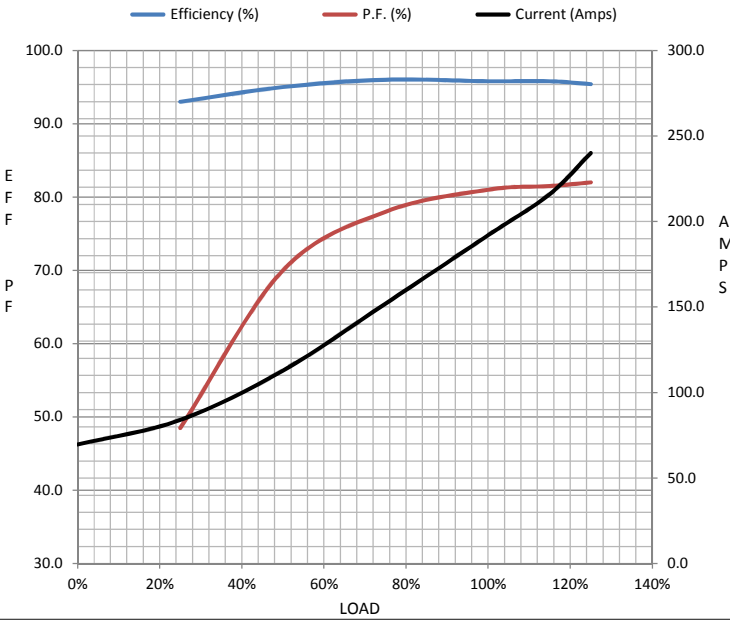

Speed -Torque Curve

