

PRODUCT INFORMATION PACKET

Model No: 449TTFS6540
Catalog No: E854
200 HP, Severe Duty Motor, 3 phase, 1800 RPM, 460 V, 449T Frame, TEFC
Severe Duty Motors



Regal and Marathon are trademarks of Regal Rexnord Corporation or one of its affiliated companies.
©2021 Regal Rexnord Corporation, All Rights Reserved. MC017097E



Nameplate Specifications

Output HP	200 Hp	Output KW	149.0 kW
Frequency	60 Hz	Voltage	460 V
Current	225.0 A	Speed	1785 rpm
Service Factor	1.15	Phase	3
Efficiency	96.5 %	Power Factor	86
Duty	Continuous	Insulation Class	H
Design Code	B	KVA Code	G
Frame	449T	Enclosure	Totally Enclosed Fan Cooled
Thermal Protection	No	Ambient Temperature	40 °C
Drive End Bearing Size	NU319	Opp Drive End Bearing Size	6318
UL	Recognized	CSA	Y
CE	Y	IP Code	54
Hazardous Location	DIVISION 2 T2B	Number of Speeds	1

Technical Specifications

Electrical Type	Squirrel Cage Inverter Rated	Starting Method	Line Or Inverter
Poles	4	Rotation	Reversible
Resistance Main	.0145 Ohms	Mounting	Rigid Base
Motor Orientation	Horizontal	Drive End Bearing	Roller
Opp Drive End Bearing	Ball	Frame Material	Cast Iron
Shaft Type	T	Overall Length	51.84 in
Frame Length	28.75 in	Shaft Diameter	3.375 in
Shaft Extension	8.81 in	Assembly/Box Mounting	F1/F2 CAPABLE
Outline Drawing	B-SS515631-2875	Connection Drawing	A-EE7300U

This is an uncontrolled document once printed or downloaded and is subject to change without notice. Date Created:10/12/2021

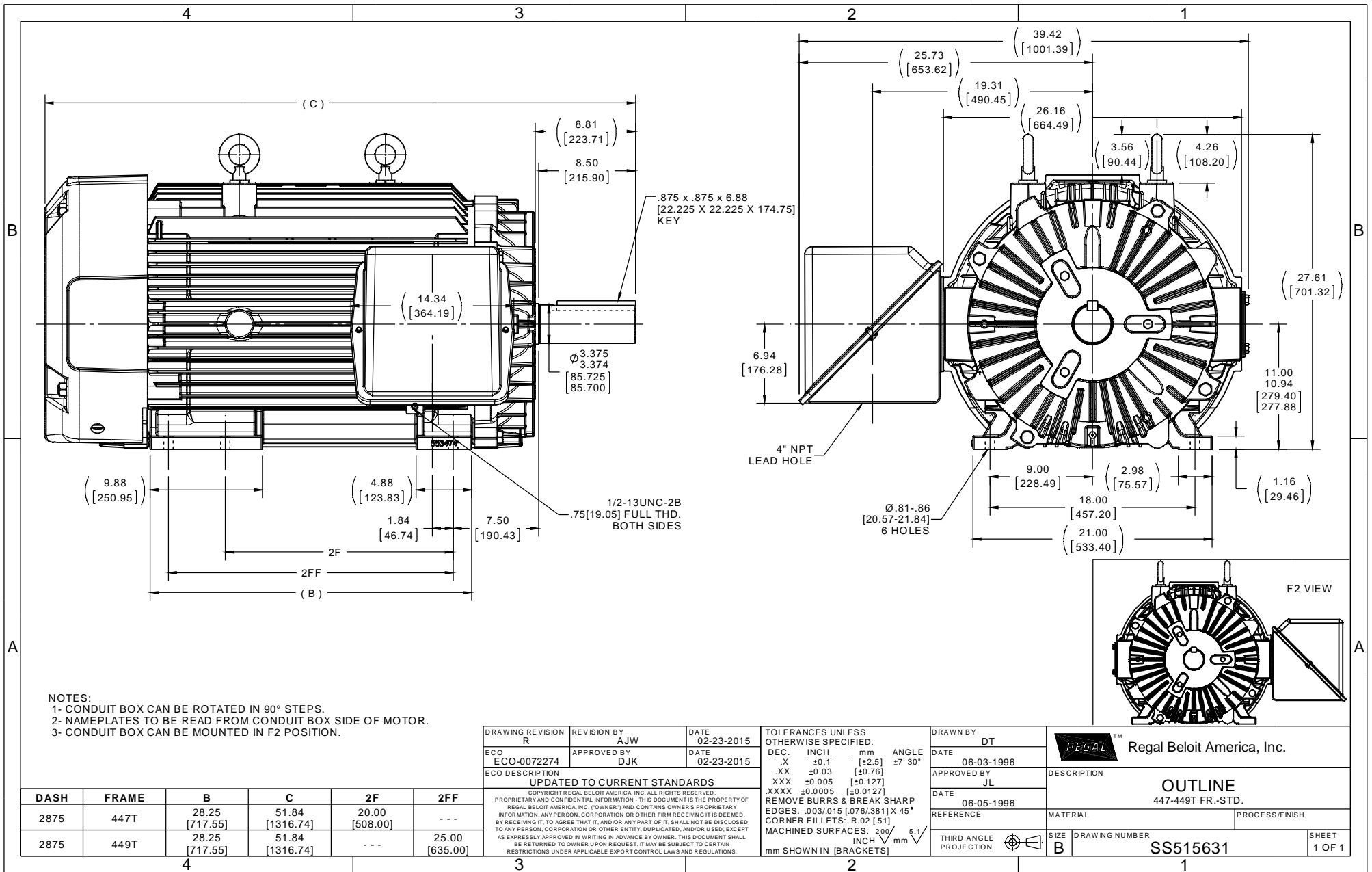

NOTES:
 1- CONDUIT BOX CAN BE ROTATED IN 90° STEPS.
 2- NAMEPLATES TO BE READ FROM CONDUIT BOX SIDE OF MOTOR.
 3- CONDUIT BOX CAN BE MOUNTED IN F2 POSITION.

DRAWING REVISION R	REVISION BY AJW	DATE 02-23-2015
ECO ECO-0072274	APPROVED BY DJK	DATE 02-23-2015
ECO DESCRIPTION UPDATED TO CURRENT STANDARDS COPYRIGHT REGAL BELOIT AMERICA, INC. ALL RIGHTS RESERVED. PROPRIETARY AND CONFIDENTIAL INFORMATION - THIS DOCUMENT IS THE PROPERTY OF REGAL BELOIT AMERICA, INC. (OWNER) AND CONTAINS OWNER'S PROPRIETARY INFORMATION. ANY PERSON, CORPORATION OR OTHER FIRM RECEIVING IT IS DEEMED, BY RECEIVING IT, TO AGREE THAT IT, AND/OR ANY PART OF IT, SHALL NOT BE DISCLOSED TO ANY PERSON, CORPORATION OR OTHER ENTITY, DUPLICATED, AND/OR USED, EXCEPT AS EXPRESSLY APPROVED IN WRITING IN ADVANCE BY OWNER. THIS DOCUMENT SHALL BE RETURNED TO OWNER UPON REQUEST. IT MAY BE SUBJECT TO CERTAIN RESTRICTIONS UNDER APPLICABLE EXPORT CONTROL LAWS AND REGULATIONS.		

TOLERANCES UNLESS OTHERWISE SPECIFIED:			
DEC.	INCH.	mm	ANGLE
.X	±0.1	[±2.5]	27° 30'
.XX	±0.03	[±0.76]	
.XXX	±0.005	[±0.127]	
.XXXX	±0.0005	[±0.0127]	
REMOVE BURRS & BREAK SHARP EDGES: .003/.015 [0.076/.381] X 45°			
CORNER FILLETS: R.02 [51]			
MACHINED SURFACES: 200 / INCH 5.1 / mm			
mm SHOWN IN [BRACKETS]			

DRAWN BY DT
DATE 06-03-1996
APPROVED BY JL
DATE 06-05-1996
REFERENCE
THIRD ANGLE PROJECTION

Regal Beloit America, Inc.	
DESCRIPTION OUTLINE 447-449T FR.-STD.	
MATERIAL	PROCESS/FINISH
SIZE B	DRAWING NUMBER SS515631
	SHEET 1 OF 1

DASH	FRAME	B	C	2F	2FF
2875	447T	28.25 [717.55]	51.84 [1316.74]	20.00 [508.00]	---
2875	449T	28.25 [717.55]	51.84 [1316.74]	---	25.00 [635.00]

IF MOTOR HAS 9 LEADS

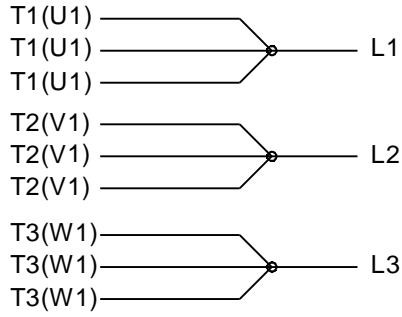

IF MOTOR HAS 6 LEADS

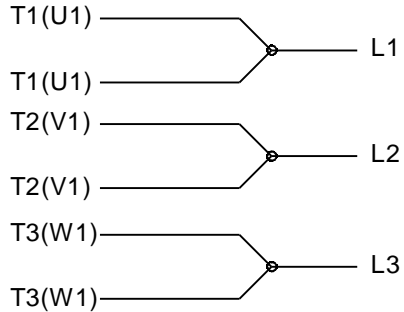

A-9806 DECAL IF CALLED FOR

IF MOTOR HAS 12 LEADS

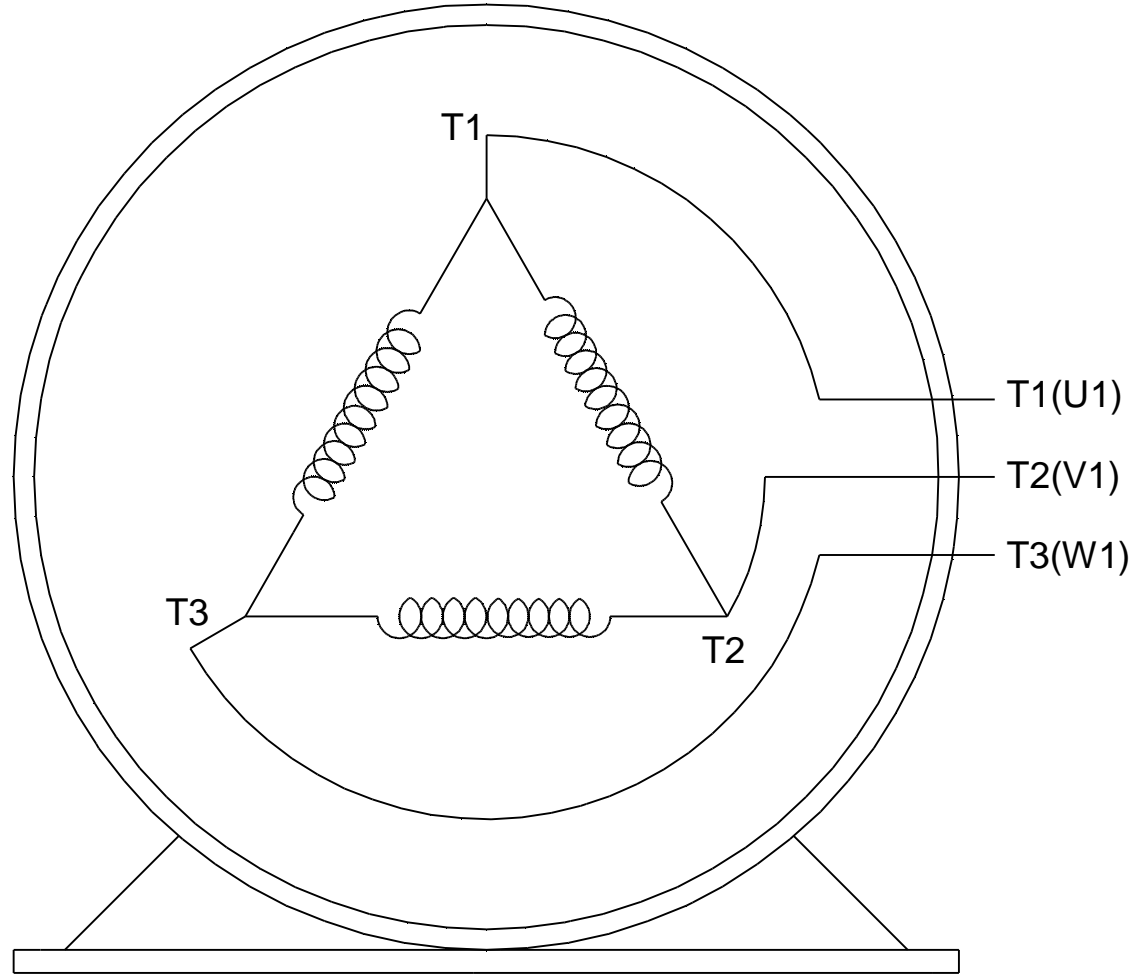

VIEW OF TERMINAL END

DRAWING REVISION L	REVISION BY AJW	DATE 05-04-2015	TOLERANCES UNLESS OTHERWISE SPECIFIED:	DRAWN BY DRS	Regal Beloit America, Inc.																					
ECO ECO-0077067	APPROVED BY EWH	DATE 05-05-2015	<table style="font-size: small; border-collapse: collapse;"> <tr> <td><u>DEC.</u></td> <td><u>INCH</u></td> <td><u>mm</u></td> <td><u>ANGLE</u></td> </tr> <tr> <td>.X</td> <td>±0.1</td> <td>[±2.5]</td> <td>±7' 30"</td> </tr> <tr> <td>.XX</td> <td>±0.02</td> <td>[±0.51]</td> <td></td> </tr> <tr> <td>.XXX</td> <td>±0.005</td> <td>[±0.127]</td> <td></td> </tr> <tr> <td>.XXXX</td> <td>±0.0005</td> <td>[±0.0127]</td> <td></td> </tr> </table>	<u>DEC.</u>			<u>INCH</u>	<u>mm</u>	<u>ANGLE</u>	.X	±0.1	[±2.5]	±7' 30"	.XX	±0.02	[±0.51]		.XXX	±0.005	[±0.127]		.XXXX	±0.0005	[±0.0127]		DATE 09-27-1996
<u>DEC.</u>	<u>INCH</u>	<u>mm</u>	<u>ANGLE</u>																							
.X	±0.1	[±2.5]	±7' 30"																							
.XX	±0.02	[±0.51]																								
.XXX	±0.005	[±0.127]																								
.XXXX	±0.0005	[±0.0127]																								
ECO DESCRIPTION UPDATED TO SOLIDWORKS <small>COPYRIGHT REGAL BELOIT AMERICA, INC. ALL RIGHTS RESERVED. PROPRIETARY AND CONFIDENTIAL INFORMATION - THIS DOCUMENT IS THE PROPERTY OF REGAL BELOIT AMERICA, INC. ("OWNER") AND CONTAINS OWNER'S PROPRIETARY INFORMATION. ANY PERSON, CORPORATION OR OTHER FIRM RECEIVING IT IS DEEMED, BY RECEIVING IT, TO AGREE THAT IT, AND/OR ANY PART OF IT, SHALL NOT BE DISCLOSED TO ANY PERSON, CORPORATION OR OTHER ENTITY, DUPLICATED, AND/OR USED, EXCEPT AS EXPRESSLY APPROVED IN WRITING IN ADVANCE BY OWNER. THIS DOCUMENT SHALL BE RETURNED TO OWNER UPON REQUEST. IT MAY BE SUBJECT TO CERTAIN RESTRICTIONS UNDER APPLICABLE EXPORT CONTROL LAWS AND REGULATIONS.</small>			APPROVED BY GK	MATERIAL	PROCESS/FINISH																					
			REMOVE BURRS & BREAK SHARP EDGES: .003/.015 [.076/.381] X 45° CORNER FILLETS: R.02 [.51] MACHINED SURFACES: 200 $\sqrt{\text{INCH}}$ 5.1 $\sqrt{\text{mm}}$ mm SHOWN IN [BRACKETS]			DATE 09-30-1996	EE7300U																			
REFERENCE	THIRD ANGLE PROJECTION	SIZE A				DRAWING NUMBER			SHEET 1 OF 1																	

CERTIFICATION DATA SHEET

Model#: 449TTFS6540 FX WINDING#: T449447 NONE 9
 CONN. DIAGRAM: A-EE7300U ASSEMBLY: F1/F2 CAPABLE
 OUTLINE: B-SS515631-2875

TYPICAL MOTOR PERFORMANCE DATA

HP	KW	SYNC. RPM	F.L. RPM	FRAME	ENCLOSURE	KVA CODE	DESIGN
200	149	1800	1785	447/449T	TEFC	G	B

PH	Hz	VOLTS	FL AMPS	START TYPE	DUTY	INSL	S.F	AMB°C	ELEVATION
3	60	460	225	LINE OR INVERTER	CONTINUOUS	H1	1.15	40	3300

FULL LOAD EFF: 96.5	3/4 LOAD EFF: 96.5	1/2 LOAD EFF: 95.4	GTD. EFF	ELEC. TYPE	NO LOAD AMPS
FULL LOAD PF: 86	3/4 LOAD PF: 84	1/2 LOAD PF: 78.5	96.2	SQ CAGE INV RATED	66

F.L. TORQUE	LOCKED ROTOR AMPS	L.R. TORQUE	B.D. TORQUE	F.L. RISE°C
588 LB-FT	1450	1100 LB-FT 187	1425 LB-FT 242	70

SOUND PRESSURE @ 3 FT.	SOUND POWER	ROTOR WK^2	MAX. WK^2	SAFE STALL TIME	STARTS /HOUR	APPROX. MOTOR WGT
75 dBA	85 dBA	77 LB-FT^2	1400 LB-FT^2	25 SEC.	1	2650 LBS.

*** SUPPLEMENTAL INFORMATION ***

DE BRACKET TYPE	ODE BRACKET TYPE	MOUNT TYPE	ORIENTATION	SEVERE DUTY	HAZARDOUS LOCATION	DRIP COVER	SCREENS	PAINT
STANDARD	STANDARD	RIGID	HORIZONTAL	PREMIUM SEVERE DUTY	DIVISION 2 T2B	FALSE	NONE	BLUE (EPOXY)

BEARINGS		GREASE	SHAFT TYPE	SPECIAL DE	SPECIAL ODE	SHAFT MATERIAL	FRAME MATERIAL
DE	OPE						
ROLLER	BALL	SHC-100/POLYREX	T	NONE	NONE	1045 HOT ROLLED (C-204)	CAST IRON
NU319	6318						

THERMO-PROTECTORS				THERMISTORS	CONTROL	SPACE /n HEATERS
THERMOSTATS	PROTECTORS	WDG RTDs	BRG RTDs			
NONE	NOT	NONE	NONE	NONE	FALSE	NONE VOLTS

If Inverter equals NONE, contact factory for further information

*
N
O
T
E
S
*

INVERTER TORQUE: CONSTANT 2:1 INV. HP SPEED RANGE: 1.5 X BASE SPEED
ENCODER: NONE NONE NONE NONE NONE PPR
BRAKE: NONE NONE NONE P/N NONE NONE NONE NONE FT-LB NONE V NONE Hz

DATE: 06/21/2017 07:19:05 AM
 FORM 3531 REV.3 02/07/99
 ** Subject to change without notice.

Data Sheet

Date: 6/20/2017

449TFS6540

Customer: _____

Attention: _____

Submitted by: FAREEDA DUDEKULA



Submittal

Data @ 460 V

Motor Load Data

Load	0%	25%	50%	75%	100%	115%	125%	LR
Current (Amps)	66.0	85.0	125	172	225	258	280	1,450
Torque (ft-lb)	0.00	146	293	440	588	677	736	1,100
RPM	1800	1795	1792	1790	1785	1,782	1780	0
Efficiency (%)		93.0	95.4	96.5	96.5	96.2	96.0	
P.F. (%)	5.5	60.0	78.5	84.0	86.0	86.5	86.5	30.0

Motor Speed Data

	LR	Pull-Up	BD	Rated	Idle
Speed (RPM)	0	900	1700	1785	1800
Current (Amps)	1,450	1,305	750	225	66.0
Torque (ft-lb)	1,100	990	1,425	588	0.00

Information Block

HP	200.0			
Sync. RPM	1800			
Frame	449			
Enclosure	TEFC			
Construction	TFN			
Voltage	460 V			
Frequency	60 Hz			
Design	A			
LR Code letter	G			
Service Factor	1.15			
Temp Rise @ FL	70 °C			
Duty	CONT			
Ambient	40 °C			
Elevation	1,000 feet			
Rotor/Shaft wk ²	77.0 Lb-Ft ²			
Ref Wdg	T449447 NONE			
Sound Pressure @ 1M	75 dBA			
VFD Rating	CONSTANT 2:1			
Outline Dwg	B-SS515631-2875			
Conn. Diag	A-EE7300U			
Additional Specifications:				
0				
0				
EQUIV CKT (OHMS / PHASE)				
R1	R2	X1	X2	Xm
0.0110	0.0070	0.0990	0.1460	3.5070

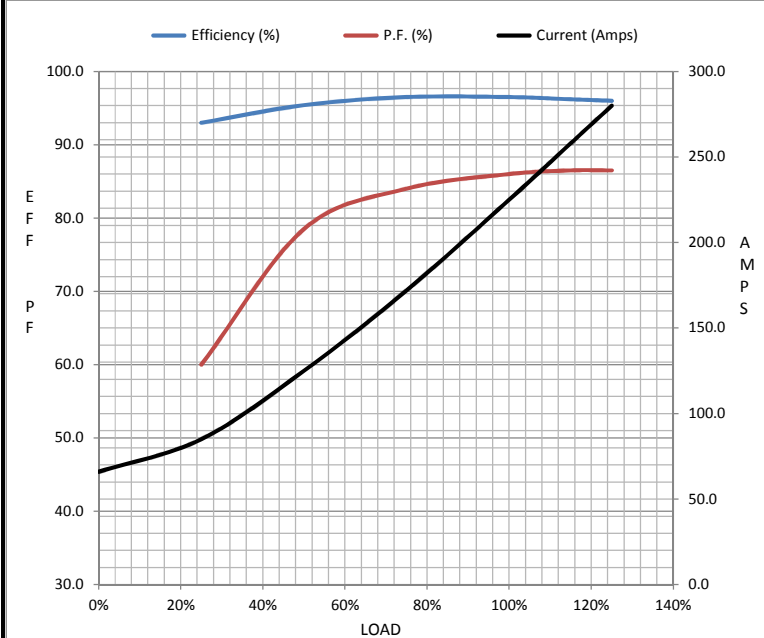

Speed - Torque Curve

