

PRODUCT INFORMATION PACKET

Model No: 449TTFS16384

Catalog No: L457A

XRI® General Purpose General Purpose Motor, 250 & 200 HP, 3 Ph, 60 & 50 Hz, 460 & 380 V,
1200 & 1000 RPM, 449T Frame, TEFC



Regal and Marathon are trademarks of Regal Rexnord Corporation or one of its affiliated companies.

©2023 Regal Rexnord Corporation, All Rights Reserved. MC017097E

Nameplate Specifications

Phase	3	Output HP	250 & 200 Hp
Output KW	187.0 & 149.0 kW	Voltage	460 & 380 V
Speed	1190 & 990 rpm	Service Factor	1.15 & 1.15
Frame	449T	Enclosure	Totally Enclosed Fan Cooled
Thermal Protection	No Protection	Efficiency	95.8 & 95.8 %
Ambient Temperature	40 °C	Frequency	60 & 50 Hz
Current	300 & 285 A	Power Factor	81
Duty	Continuous	Insulation Class	H
Design Code	B	KVA Code	G
Drive End Bearing Size	6319	Opp Drive End Bearing Size	6318
UL	Recognized	CSA	Y
CE	Y	IP Code	43
Number of Speeds	1		

Technical Specifications

Electrical Type	Squirrel Cage Inverter Rated	Starting Method	Line Or Inverter
Poles	6	Rotation	Reversible
Resistance Main	.012 Ohms	Mounting	Rigid Base
Motor Orientation	Horizontal	Drive End Bearing	Ball
Opp Drive End Bearing	Ball	Frame Material	Cast Iron
Shaft Type	T	Overall Length	28.25 in
Frame Length	28.77 in	Shaft Diameter	3.375 in
Shaft Extension	8.75 in	Assembly/Box Mounting	F1/F2 CAPABLE
Connection Drawing	A-EE7300BH	Outline Drawing	B-SS515635-2875

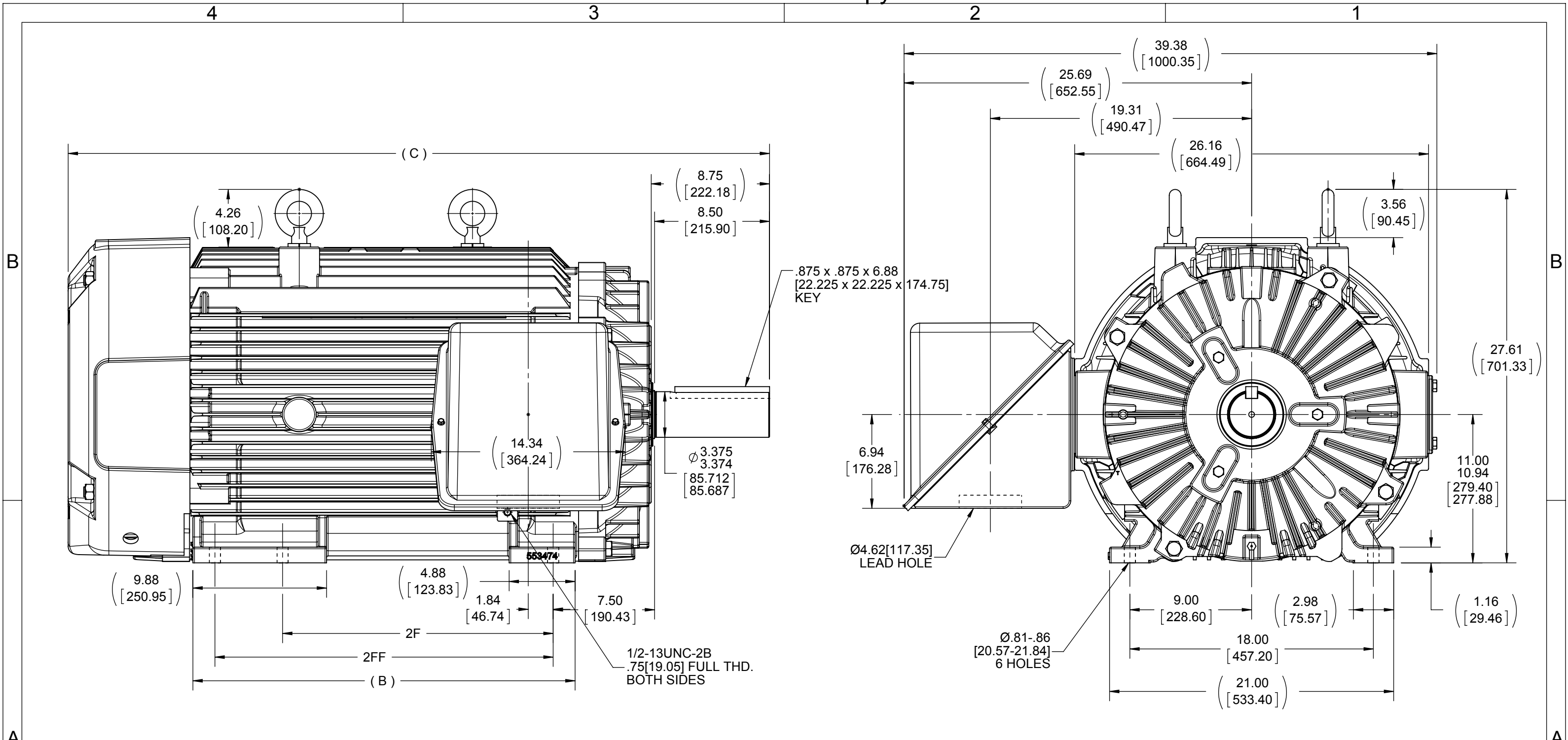

- NOTES:
 1- C'BOX CAN BE ROTATED IN 90° STEPS.
 2- NAMEPLATES TO BE READ FROM C'BOX SIDE OF MOTOR.
 3- C'BOX CAN BE MOUNTED IN F2 POSITION.

DASH	FRAME	B	C	2F	2FF
2875	447T	28.25 [717.55]	51.86 [1317.24]	20.00 [508.00]	---
2875	449T	28.25 [717.55]	51.86 [1317.24]	---	25.00 [635.00]

DRAWING REVISION D	REVISION BY CM	DATE 04-11-2014
ECO ECO-0049191	APPROVED BY DJK	DATE 04-11-2014
ECO DESCRIPTION UPDATE TO CURRENT STANDARDS		
<small>COPYRIGHT REGAL BELOIT AMERICA, INC. ALL RIGHTS RESERVED. PROPRIETARY AND CONFIDENTIAL INFORMATION - THIS DOCUMENT IS THE PROPERTY OF REGAL BELOIT AMERICA, INC. ("OWNER") AND CONTAINS OWNER'S PROPRIETARY INFORMATION. ANY PERSON, CORPORATION OR OTHER FIRM RECEIVING IT IS DEEMED, BY RECEIVING IT, TO AGREE THAT IT, AND/OR ANY PART OF IT, SHALL NOT BE DISCLOSED TO ANY PERSON, CORPORATION OR OTHER ENTITY, DUPLICATED, AND/OR USED, EXCEPT AS EXPRESSLY APPROVED IN WRITING IN ADVANCE BY OWNER. THIS DOCUMENT SHALL BE RETURNED TO OWNER UPON REQUEST. IT MAY BE SUBJECT TO CERTAIN RESTRICTIONS UNDER APPLICABLE EXPORT CONTROL LAWS AND REGULATIONS.</small>		

TOLERANCES UNLESS OTHERWISE SPECIFIED:			
DEC.	INCH	mm	ANGLE
.X	±0.1	[±2.5]	±7° 30"
.XX	±0.03	[±0.76]	
.XXX	±0.005	[±0.127]	
.XXXX	±0.0005	[±0.0127]	
REMOVE BURRS & BREAK SHARP EDGES: .003/.015 [0.076/.381]			
CORNER FILLETS: .02 [0.51]			
MACHINED SURFACES: 200 INCH 5.1 mm			
mm SHOWN IN [BRACKETS]			

DRAWN BY DT
DATE 06-04-1996
APPROVED BY JL
DATE 06-05-1996
PROCESS/FINISH
THIRD ANGLE PROJECTION

Regal Beloit America, Inc.	
DESCRIPTION OUTLINE 447-449T FR. - STD.	
MATERIAL	
SIZE B	DRAWING NUMBER SS515635
SHEET 1 OF 1	



VIEW OF TERMINAL END

				TOLERANCES UNLESS SPECIFIED		REGAL REGAL - BELOIT CORPORATION	DRAWN RJW 02-11-2005			
				DEC.	INCHES		CHK	ML	02-11-2005	
				.X	±.1		APPD	GK	02-11-2005	
				.XX	±.02	TITLE CONNECTION DIAGRAM		SCALE		
D	CHANGED TO REGAL TITLE BLOCK	ECO-0108299	WGJ 08/22/2016	EMH	.XXX ±.005	12 LEAD- SINGLE VOLTAGE		REF		
1	ADDED IEC TERMINAL MARKINGS	CN 41429	JJB 05/24/2007	ML	.XXXX ±.0005	MAT'L.		FMF		
NO.	REVISION	BY & DATE	CHK	ANG	±7'30"	FINISH		PREV		
THIS DRAWING IN DESIGN AND DETAIL IS OUR PROPERTY AND MUST NOT BE USED EXCEPT IN CONNECTION WITH OUR WORK ALL RIGHTS OF DESIGN AND INVENTION ARE RESERVED THIS IS AN ELECTRONICALLY GENERATED DOCUMENT - DO NOT SCALE THIS PRINT				RFP	02-11-2005	CAD FILE ee7300bh	SIZE	DRAWING NO.	PAGE OF	REV.
				DIST	LB		A	EE7300BH		C



P.O. BOX 8003
 WAUSAU, WI 54401-8003
 PH. 715-675-3311

DATA VOLTS: 460

CERTIFICATION DATA SHEET

CUSTOMER: _____ **CUSTOMER P.O. #:** _____
ORDER #: _____ **REFERENCE MODEL #:** 449TTFS16384
CONN. DIAGRAM: A-EE7300BH **CAT #:** L457A
OUTLINE: B-SS515635-2875 **CUSTOMER PART #:** _____
WINDING: T449626 NONE 13 **MOUNTING:** F1/F2 CAPABLE
SPEED: _____

TYPICAL MOTOR PERFORMANCE DATA

HP	KW	SYNC RPM	FL RPM	FRAME	ENCLOSURE	TYPE	KVA CODE	DESIGN
250	187	1200	1190	447/449T	TEFC	TFN	G	B

PH	HZ	VOLTS	AMPS	START TYPE	DUTY	INSL	S.F.	AMB	ELEV.
3	60/50	460#380	300&285	LINE OR INVERTER	CONT	H	1.15	40	3300

F.L. EFF	95.8	3/4 LD EFF	96.0	1/2 LD EFF	95.4	GTD EFF	95.4	ELECT. TYPE	SQ CAGE INV RATED
F.L. PF	81.0	3/4 LD PF	79.0	1/2 LD PF	70.0				

F.L. TORQUE	LR AMPS @ 460 V	L.R. TORQUE	B.D. TORQUE	F.L. RISE (°C)
1,103 LB-FT	1,825	1,825 LB-FT 165%	2,825 LB-FT 256%	65

@ 3 FT.	POWER	ROTOR WK ²	MAX. LOAD WK ²	SAFE STALL TIME	STARTS/HOUR	MOTOR WGT
75 dBA	84 dBA	138 LB-FT ²	3600 LB-FT ²	25 SEC.	2	3250 LB.

***** SUPPLEMENTAL INFORMATION *****

DE BRACKET TYPE	ODE BRACKET TYPE	MOUNT TYPE	MOTOR ORIENTATION	SEVERE DUTY	HAZARDOUS LOCATION	DRIP COVER	SCREENS	PAINT
STANDARD	STANDARD	RIGID	HORIZONTAL	NO	NONE	NO	NONE	BLUE (ENAMEL)

BEARINGS		GREASE	SHAFT TYPE	SPECIAL DE	SPECIAL ODE	SHAFT MATERIAL	FRAME MATERIAL
DE	ODE						
BALL	BALL	POLYREX EM	T	NONE	NONE	1045 HOT ROLLED (C-204)	CAST IRON
6319	6318						

THERMOSTATS	PROTECTORS	WDG RTD's	BRG RTD's	THERMISTORS	CONTROL	SPACE HEATERS
NONE	NOT	NONE	NONE	NONE	FALSE	NA

R1 (ohms/ph)	R2 (ohms/ph)	X1 (ohms/ph)	X2 (ohms/ph)	Xm (ohms/ph)	VIBRATION (in/sec)	FLOAT
0.008	0.008	0.096	0.129	2.177	0.150	ODE

* N O T E S *	INVERTER TORQUE: CONSTANT 2:1 INV. HP SPEED RANGE: NONE					
	ENCODER: NONE NONE NONE					
	NONE PPR					
	BRAKE: NONE NONE					
	NONE					

PREPARED BY: FAREEDA DUDEKULA DATE: 9/10/2018	FT-LB: NA VOLTAGE: NONE HZ:
UL: V-INS, CONST UL REC	

FORM: 3531 REV_4 2/27/06

Data Sheet

Date: 11/29/2018
 Customer: _____
 Attention: _____
 Submitted by: FAREEDA DUDEKULA



449TFS16384

Submittal

Data @ 460 V

Motor Load Data

Load	0%	25%	50%	75%	100%	115%	125%	LR
Current (Amps)	115	130	175	230	300	330	365	1,825
Torque (ft-lb)	0.00	275	550	825	1,103	1,245	1,385	1,825
RPM	1200	1196	1194	1192	1190	1,188	1186	0
Efficiency (%)		92.4	95.4	96.0	95.8	95.8	95.8	
P.F. (%)	3.5	49.0	70.0	79.0	81.0	82.5	83.0	23.0

Motor Speed Data

	LR	Pull-Up	BD	Rated	Idle
Speed (RPM)	0	600	1150	1190	1200
Current (Amps)	1,825	1,700	1,125	300	115
Torque (ft-lb)	1,825	1,700	2,825	1,103	0.00

Information Block

HP	250.0			
Sync. RPM	1200			
Frame	449			
Enclosure	TEFC			
Construction	TFS			
Voltage	460#380 V			
Frequency	60 Hz			
Design	B			
LR Code letter	G			
Service Factor	1.15			
Temp Rise @ FL	65 °C			
Duty	CONT			
Ambient	40 °C			
Elevation	1,000 feet			
Rotor/Shaft wk ²	138 Lb-Ft ²			
Ref Wdg	T449626 NONE			
Sound Pressure @ 1M	75 dBA			
VFD Rating	CONSTANT 2:1			
Outline Dwg	B-SS515635-2875			
Conn. Diag	A-EE7300BH			
Additional Specifications:				
0				
0				
EQUIV CKT (OHMS / PHASE)				
R1	R2	X1	X2	Xm
0.0080	0.0080	0.0960	0.1290	2.1770

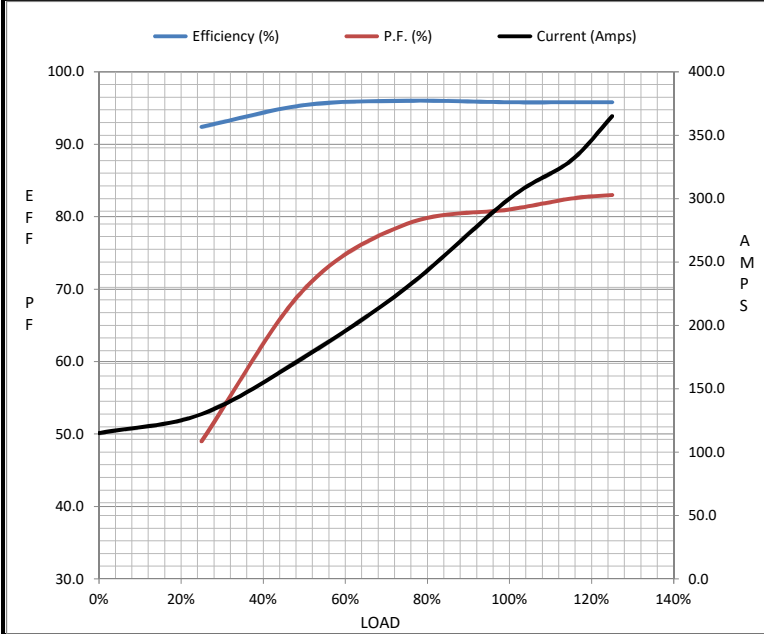

Speed - Torque Curve

