

PRODUCT INFORMATION PACKET

marathon[®]
Motors

Model No: 449TSTDN7026

Catalog No: H815

Other Purpose Motor, 450 & 350 HP, 3 Ph, 60 & 50 Hz, 460 & 380 V, 1800 & 1500 RPM, 449TS Frame, DP

Regal and Marathon are trademarks of Regal Rexnord Corporation or one of its affiliated companies.

©2023 Regal Rexnord Corporation, All Rights Reserved. MC017097E

RegalRexnord



Nameplate Specifications

Phase	3	Output HP	450 & 350 Hp
Output KW	340.0 & 260.0 kW	Voltage	460 & 380 V
Speed	1780 & 1482 rpm	Service Factor	1.15 & 1.15
Frame	449TS	Enclosure	Drip Proof
Thermal Protection	No Protection	Efficiency	95.4 & 95 %
Ambient Temperature	40 °C	Frequency	60 & 50 Hz
Current	510 & 475 A	Power Factor	86.5
Duty	Continuous	Insulation Class	F
Design Code	B	KVA Code	F
Drive End Bearing Size	6314	Opp Drive End Bearing Size	6314
UL	No	CSA	Y
CE	Y	IP Code	12
Number of Speeds	1		

Technical Specifications

Electrical Type	Squirrel Cage Induction Run	Starting Method	Part Wdg Start & Wye Start Delta Run
Poles	4	Rotation	Reversible
Resistance Main	.0099 Ohms	Mounting	Rigid Base
Motor Orientation	Horizontal	Drive End Bearing	Ball
Opp Drive End Bearing	Ball	Frame Material	Cast Iron
Shaft Type	TS	Overall Length	44.50 in
Frame Length	29.38 in	Shaft Diameter	2.375 in
Shaft Extension	5 in	Assembly/Box Mounting	F1/F2 CAPABLE
Connection Drawing	A-EE7300CB	Outline Drawing	B-SS514570-2938

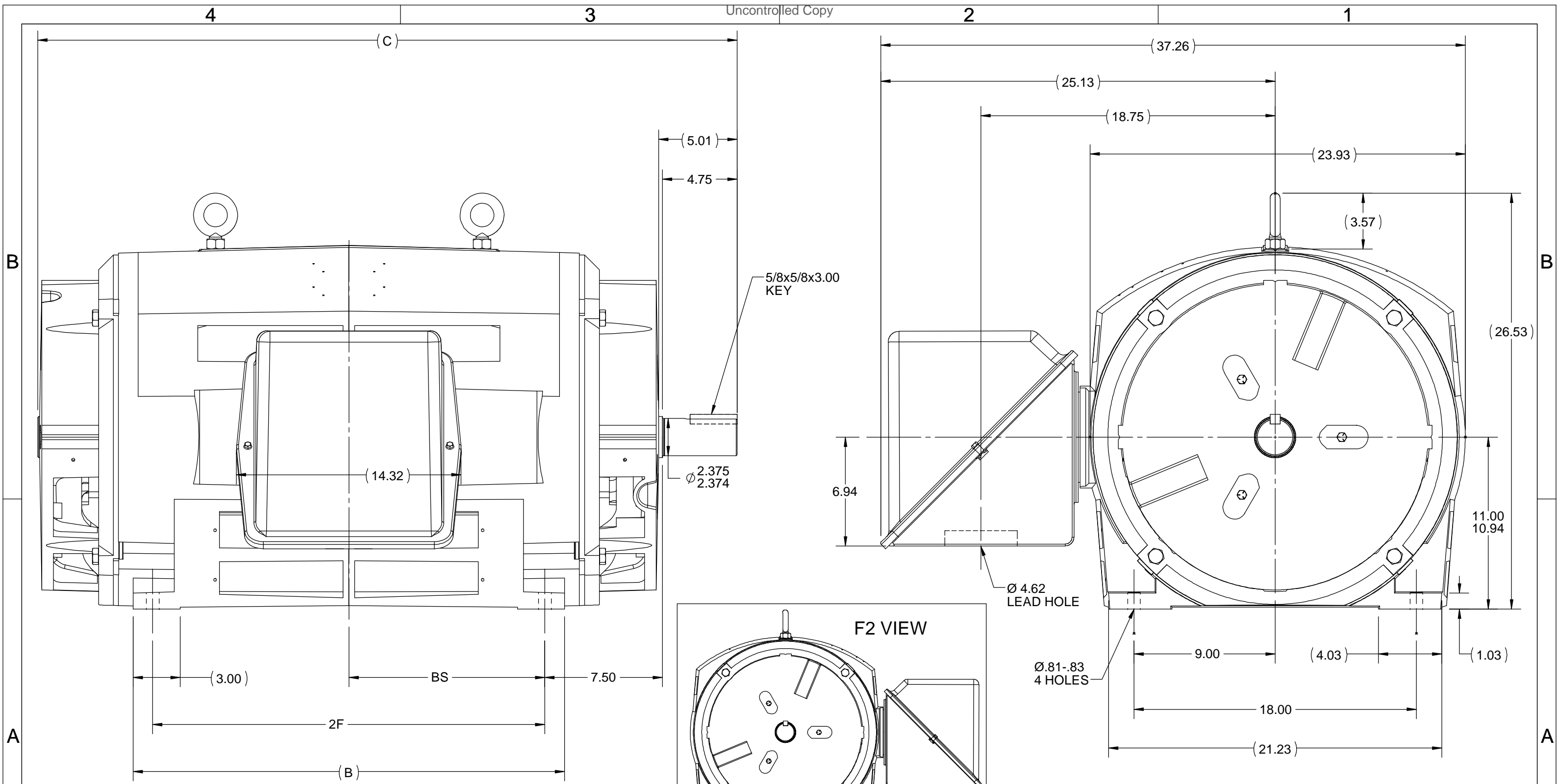

NOTES:
 1. C.BOX CAN BE ROTATED IN 90° STEPS.
 2. C.BOX CAN BE MOUNTED ON OPPOSITE SIDE BY REMOVING BRACKETS & TURNING FRAME 180°.
 3. NAMEPLATE TO BE READ FROM CONDUIT BOX SIDE OF MOTOR.

DASH	FRAME	C	B	2F	BS
2438	447TS	39.58	22.50	20.00	10.00
2938	449TS	44.58	27.50	25.00	12.50

DRAWING REVISION C	REVISION BY JP	DATE 06-08-2018
ECO ECO-0146457	APPROVED BY DJK	DATE 06-08-2018
ECO DESCRIPTION MU129250/NMR-0154521		
<small>COPYRIGHT REGAL BELOIT AMERICA, INC. ALL RIGHTS RESERVED. PROPRIETARY AND CONFIDENTIAL INFORMATION - THIS DOCUMENT IS THE PROPERTY OF REGAL BELOIT AMERICA, INC. ("OWNER") AND CONTAINS OWNER'S PROPRIETARY INFORMATION. ANY PERSON, CORPORATION OR OTHER FIRM RECEIVING IT IS DEEMED, BY RECEIVING IT, TO AGREE THAT IT, AND/OR ANY PART OF IT, SHALL NOT BE DISCLOSED TO ANY PERSON, CORPORATION OR OTHER ENTITY, DUPLICATED, AND/OR USED, EXCEPT AS EXPRESSLY APPROVED IN WRITING IN ADVANCE BY OWNER. THIS DOCUMENT SHALL BE RETURNED TO OWNER UPON REQUEST. IT MAY BE SUBJECT TO CERTAIN RESTRICTIONS UNDER APPLICABLE EXPORT CONTROL LAWS AND REGULATIONS.</small>		

TOLERANCES UNLESS OTHERWISE SPECIFIED:

DEC.	INCH	mm	ANGLE
.X	± 0.1	[± 2.5]	$\pm 7' 30''$
.XX	± 0.03	[± 0.76]	
.XXX	± 0.005	[± 0.127]	
.XXXX	± 0.0005	[± 0.0127]	

REMOVE BURRS & BREAK SHARP EDGES: .003/.015 [.076/.381] X 45° CORNER FILLETS: R.02 [.51] MACHINED SURFACES: 200 INCH/mm 5.1 mm SHOWN IN [BRACKETS]

DRAWN BY KL	DATE 06-19-1993
APPROVED BY JL	DATE 06-20-1993
REFERENCE	
THIRD ANGLE PROJECTION	

REGAL ™ Regal Beloit America, Inc.	
DESCRIPTION OUTLINE 447/449TS FR. - DR. PR.	
MATERIAL	PROCESS/FINISH
SIZE B	DRAWING NUMBER SS514570
	SHEET 1 OF 1

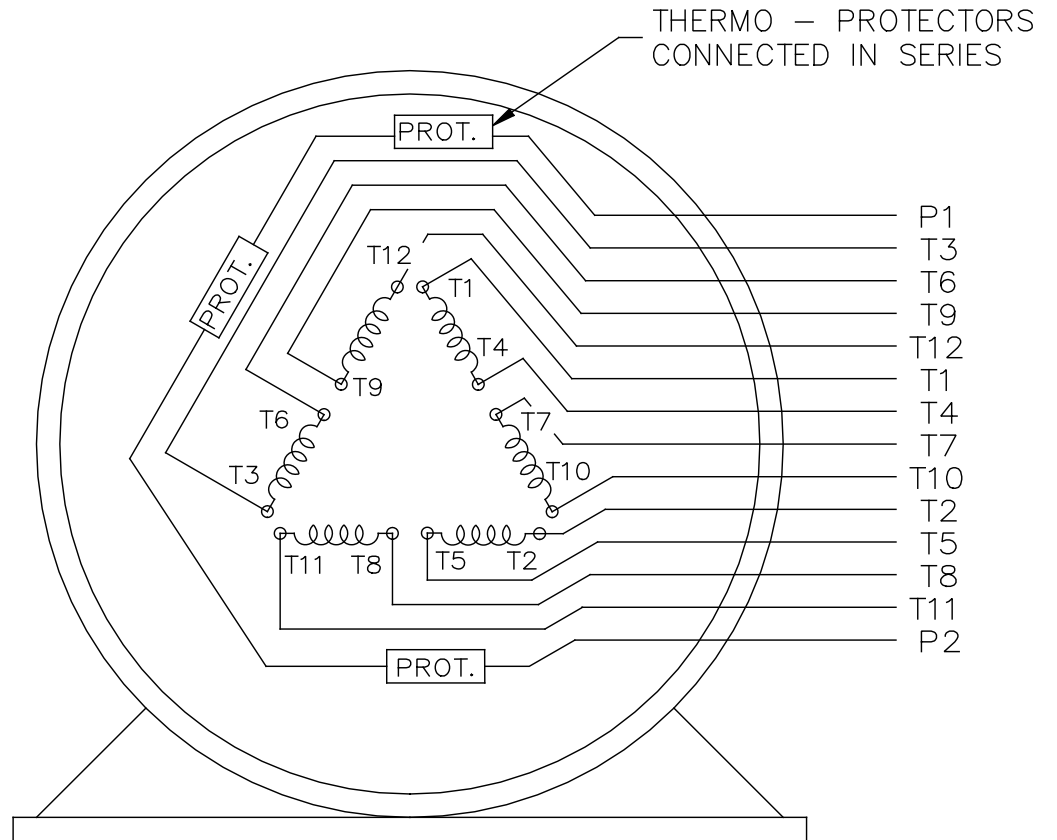
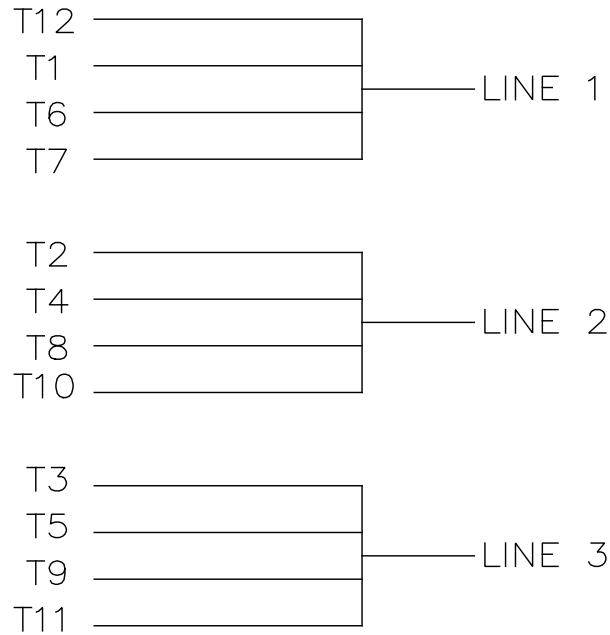

THERMO - PROTECTORS
CONNECTED IN SERIES

VIEW OF TERMINAL END

				TOLERANCES UNLESS SPECIFIED		REGAL REGAL - BELOIT CORPORATION	DRAWN KL 02-27-2003				
				DEC.	INCHES		CHK GFH 03-03-2003				
				.X	± -		APPD JES 03-03-2003				
				.XX	± -	TITLE CONNECTION DIAGRAM - EXTERNAL	SCALE 1=1				
				.XXX	± -	12 LEAD SINGLE VOLTAGE	REF				
A	CHANGED TO REGAL TITLEBLOCK	ECO-0108299	WGJ 08-18-2016	EMH	.XXXX ± -	MAT'L.	FMF				
NO.	REVISION	BY & DATE	CHK	ANG	± -	FINISH	PREV				
THIS DRAWING IN DESIGN AND DETAIL IS OUR PROPERTY AND MUST NOT BE USED EXCEPT IN CONNECTION WITH OUR WORK ALL RIGHTS OF DESIGN AND INVENTION ARE RESERVED THIS IS AN ELECTRONICALLY GENERATED DOCUMENT - DO NOT SCALE THIS PRINT						RFP	CAD FILE EE7300CB	SIZE A	DRAWING NO. EE7300CB	PAGE OF	REV.
						DIST					