

PRODUCT INFORMATION PACKET

Model No: 449THFS9028

Catalog No: W626

250 HP, Severe Duty Motor, 3 phase, 1800 RPM, 460 V, 449T Frame, TEFC
Severe Duty Motors



Regal and Marathon are trademarks of Regal Rexnord Corporation or one of its affiliated companies.
©2021 Regal Rexnord Corporation, All Rights Reserved. MC017097E



Nameplate Specifications

Output HP	250 Hp	Output KW	187.0 kW
Frequency	60 Hz	Voltage	460 V
Current	285.0 A	Speed	1785 rpm
Service Factor	1.15	Phase	3
Efficiency	96.5 %	Power Factor	86
Duty	Continuous	Insulation Class	F
Design Code	B	KVA Code	G
Frame	449T	Enclosure	Totally Enclosed Fan Cooled
Thermal Protection	No	Ambient Temperature	40 °C
Drive End Bearing Size	6319	Opp Drive End Bearing Size	6318
UL	Recognized	CSA	Y
CE	Y	IP Code	56
Hazardous Location	DIVISION 2 T2B	Number of Speeds	1

Technical Specifications

Electrical Type	Squirrel Cage Inverter Rated	Starting Method	Line Or Inverter
Poles	4	Rotation	Reversible
Resistance Main	.0107 Ohms	Mounting	Rigid Base
Motor Orientation	Horizontal	Drive End Bearing	Ball
Opp Drive End Bearing	Ball	Frame Material	Cast Iron
Shaft Type	T	Overall Length	51.84 in
Frame Length	28.75 in	Shaft Diameter	3.375 in
Shaft Extension	8.81 in	Assembly/Box Mounting	F1/F2 CAPABLE
Outline Drawing	B-SS515631-2875	Connection Drawing	A-EE7300

This is an uncontrolled document once printed or downloaded and is subject to change without notice. Date Created:10/12/2021

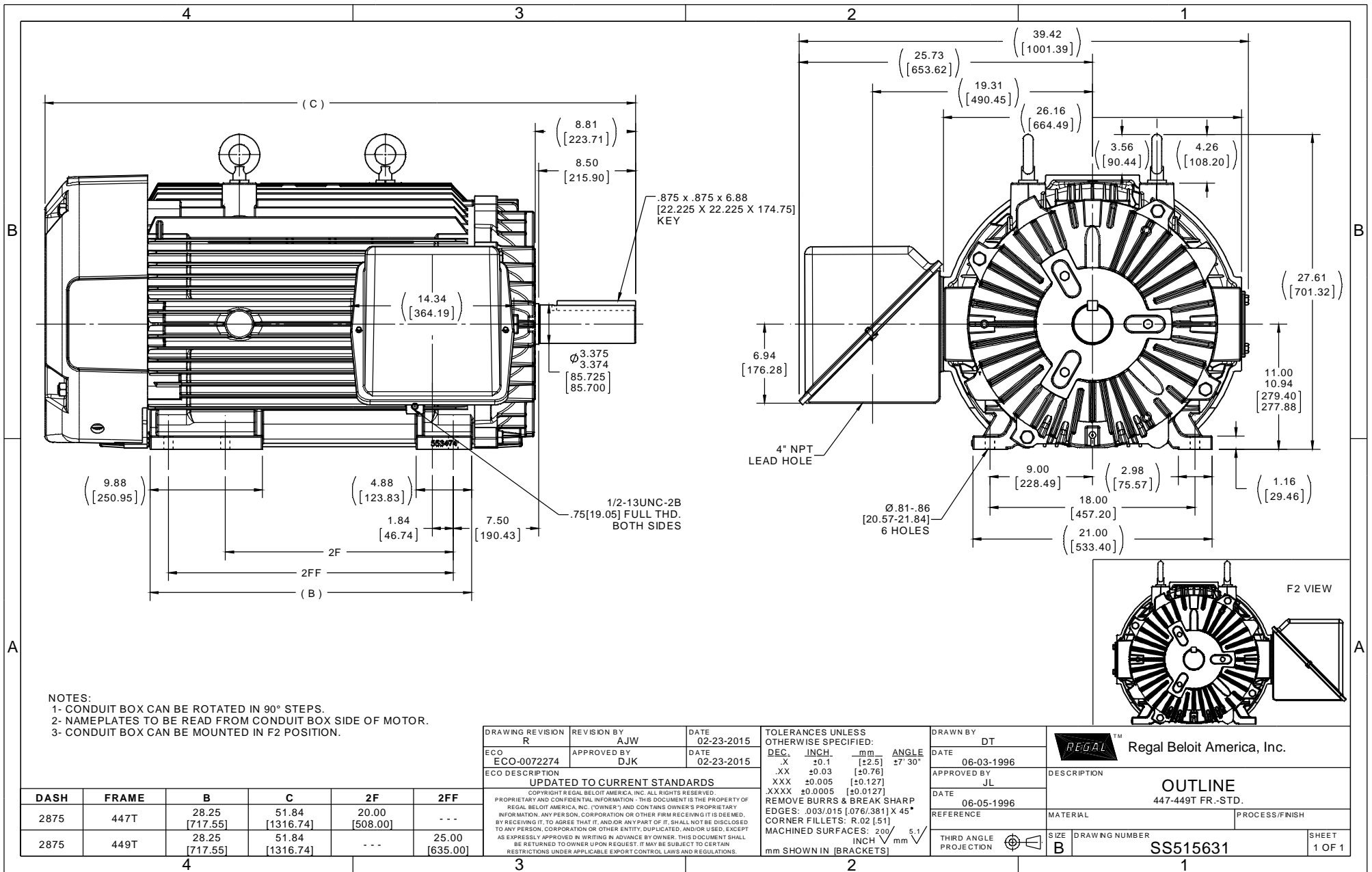

NOTES:
 1- CONDUIT BOX CAN BE ROTATED IN 90° STEPS.
 2- NAMEPLATES TO BE READ FROM CONDUIT BOX SIDE OF MOTOR.
 3- CONDUIT BOX CAN BE MOUNTED IN F2 POSITION.

DASH	FRAME	B	C	2F	2FF
2875	447T	28.25 [717.55]	51.84 [1316.74]	20.00 [508.00]	---
2875	449T	28.25 [717.55]	51.84 [1316.74]	---	25.00 [635.00]

DRAWING REVISION R	REVISION BY AJW	DATE 02-23-2015	TOLERANCES UNLESS OTHERWISE SPECIFIED: DEC. INCH. mm ANGLE .X ±0.1 [±2.5] 27° 30' .XX ±0.03 [±0.76] .XXX ±0.005 [±0.127] XXXX ±0.0005 [±0.0127] REMOVE BURRS & BREAK SHARP EDGES: .003/.015 [0.076/.381] X 45° CORNER FILLETS: R.02 [51] MACHINED SURFACES: 200 / INCH 5.1 / mm	DRAWN BY DT	Regal Beloit America, Inc.	
ECO ECO-0072274	APPROVED BY DJK	DATE 02-23-2015	DATE 06-03-1996	APPROVED BY JL		
UPDATED TO CURRENT STANDARDS COPYRIGHT © REGAL BELOIT AMERICA, INC. ALL RIGHTS RESERVED. PROPRIETARY AND CONFIDENTIAL INFORMATION - THIS DOCUMENT IS THE PROPERTY OF REGAL BELOIT AMERICA, INC. (OWNER) AND CONTAINS OWNER'S PROPRIETARY INFORMATION. ANY PERSON, CORPORATION OR OTHER FIRM RECEIVING IT IS DEEMED, BY RECEIVING IT, TO AGREE THAT IT, AND/OR ANY PART OF IT, SHALL NOT BE DISCLOSED TO ANY PERSON, CORPORATION OR OTHER ENTITY, DUPLICATED, AND/OR USED, EXCEPT AS EXPRESSLY APPROVED IN WRITING IN ADVANCE BY OWNER. THIS DOCUMENT SHALL BE RETURNED TO OWNER UPON REQUEST. IT MAY BE SUBJECT TO CERTAIN RESTRICTIONS UNDER APPLICABLE EXPORT CONTROL LAWS AND REGULATIONS.			DATE 06-05-1996	DESCRIPTION OUTLINE 447-449T FR.-STD.		
			REFERENCE	MATERIAL		PROCESS/FINISH
			THIRD ANGLE PROJECTION	SIZE B	DRAWING NUMBER SS515631	SHEET 1 OF 1

**THREE PHASE - SINGLE VOLTAGE
MOTOR - CONDUIT BOX @ 'A'**

**TO REVERSE ROTATION:
INTERCHANGE ANY TWO
LINE LEAD CONNECTIONS.**

TERMINAL BLOCK WHEN SPECIFIED



VIEW OF TERMINAL END

**IF MOTOR HAS
6 LEADS**

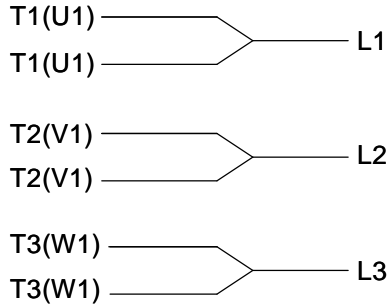

A-9806 DECAL

**OPTIONAL CORD
CONNECTION**



DRAWING REVISION AB	REVISION BY JJB	DATE 06-27-2017
ECO ECO-0125361	APPROVED BY TB	DATE 06-27-2017
ECO DESCRIPTION UPDATED TO CURRENT STANDARDS		
<small>COPYRIGHT REGAL BELOIT AMERICA, INC. ALL RIGHTS RESERVED. PROPRIETARY AND CONFIDENTIAL INFORMATION - THIS DOCUMENT IS THE PROPERTY OF REGAL BELOIT AMERICA, INC. ("OWNER") AND CONTAINS OWNER'S PROPRIETARY INFORMATION. ANY PERSON, CORPORATION OR OTHER FIRM RECEIVING IT IS DEEMED, BY RECEIVING IT, TO AGREE THAT IT, AND/OR ANY PART OF IT, SHALL NOT BE DISCLOSED TO ANY PERSON, CORPORATION OR OTHER ENTITY, DUPLICATED, AND/OR USED, EXCEPT AS EXPRESSLY APPROVED IN WRITING IN ADVANCE BY OWNER. THIS DOCUMENT SHALL BE RETURNED TO OWNER UPON REQUEST. IT MAY BE SUBJECT TO CERTAIN RESTRICTIONS UNDER APPLICABLE EXPORT CONTROL LAWS AND REGULATIONS.</small>		



DRAWN BY DA
DATE 03-26-1993
APPROVED BY TB
DATE 03-26-1993
REFERENCE
THIRD ANGLE PROJECTION

Regal Beloit America, Inc.	
DESCRIPTION CONNECTION DIAGRAM EXTERNAL - SINGLE VOLTAGE - 3Ø MOTOR	
MATERIAL	PROCESS/FINISH
SIZE A	DRAWING NUMBER EE7300
SHEET 1 OF 1	

Data Sheet

Date: 29-06-2017
 Customer: _____
 Attention: _____
 Submitted by: FAREEDA DUDEKULA



449THFS9028

Submittal

Data @ 460 V

Motor Load Data

Load	0%	25%	50%	75%	100%	115%	125%	LR
Current (Amps)	87.0	110	158	217	285	322	352	1,825
Torque (ft-lb)	0.00	183	366	550	736	846	920	1,450
RPM	1800	1796	1794	1790	1785	1,782	1780	0
Efficiency (%)		93.0	95.8	96.5	96.5	96.5	96.2	
P.F. (%)	4.5	57.0	77.0	83.5	86.0	86.5	86.5	31.0

Motor Speed Data

	LR	Pull-Up	BD	Rated	Idle
Speed (RPM)	0	900	1725	1785	1800
Current (Amps)	1,825	1,725	1,100	285	87.0
Torque (ft-lb)	1,450	1,250	1,825	736	0.00

Information Block				
HP	250.0			
Sync. RPM	1800			
Frame	449			
Enclosure	TEFC			
Construction	TFN			
Voltage	460 V			
Frequency	60 Hz			
Design	A			
LR Code letter	G			
Service Factor	1.15			
Temp Rise @ FL	65 °C			
Duty	CONT			
Ambient	40 °C			
Elevation	1,000 feet			
Rotor/Shaft wk ²	81.0 Lb-Ft ²			
Ref Wdg	T449446 NONE			
Sound Pressure @ 1M	80 dBA			
VFD Rating	CONSTANT 10:1			
Outline Dwg	B-SS515631-2875			
Conn. Diag	A-EE7300			
Additional Specifications:				
0				
365THFS8036				
EQUIV CKT (OHMS / PHASE)				
R1	R2	X1	X2	Xm
0.0070	0.0070	0.0920	0.1300	2.9720

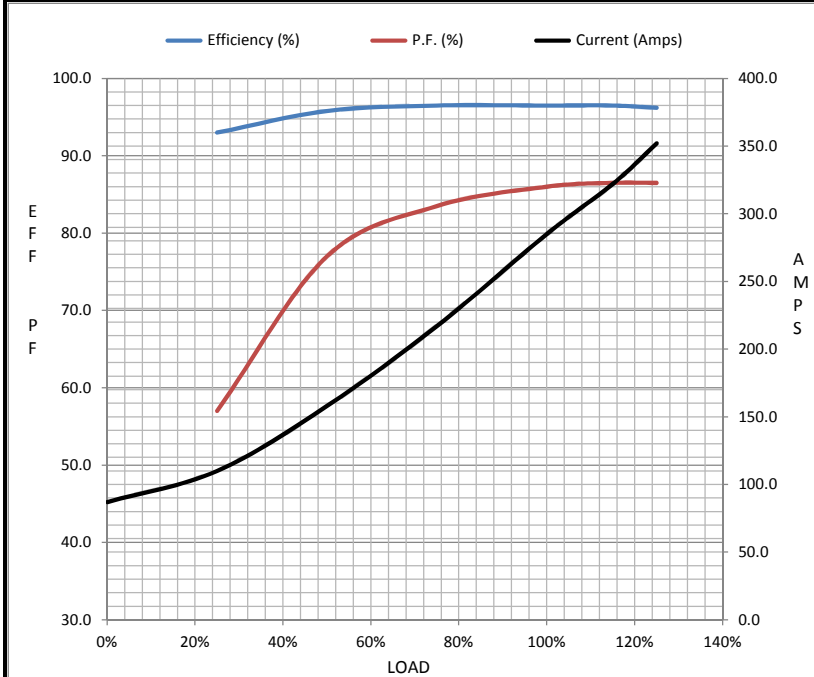

Speed - Torque Curve

