

# PRODUCT INFORMATION PACKET

Model No: 447TSTFC6005

Catalog No: GT1154

Globetrotter® General Purpose Motor, 200 HP, 3 Ph, 60 Hz, 575 V, 3600 RPM, 447TS Frame, TEFC



Regal and Marathon are trademarks of Regal Rexnord Corporation or one of its affiliated companies.

©2023 Regal Rexnord Corporation, All Rights Reserved. MC017097E

### Nameplate Specifications

Phase	<b>3</b>	Output HP	<b>200 Hp</b>
Output KW	<b>149.0 kW</b>	Voltage	<b>575 V</b>
Speed	<b>3585 rpm</b>	Service Factor	<b>1.15</b>
Frame	<b>447TS</b>	Enclosure	<b>Totally Enclosed Fan Cooled</b>
Thermal Protection	<b>No Protection</b>	Efficiency	<b>95.4 %</b>
Ambient Temperature	<b>40 °C</b>	Frequency	<b>60 Hz</b>
Current	<b>172.0 A</b>	Power Factor	<b>90</b>
Duty	<b>Continuous</b>	Insulation Class	<b>F</b>
Design Code	<b>B</b>	KVA Code	<b>G</b>
Drive End Bearing Size	<b>6314</b>	Opp Drive End Bearing Size	<b>6314</b>
UL	<b>Recognized</b>	CSA	<b>Y</b>
CE	<b>Y</b>	IP Code	<b>43</b>
Number of Speeds	<b>1</b>		

### Technical Specifications

Electrical Type	<b>Squirrel Cage Induction Run</b>	Starting Method	<b>Across The Line</b>
Poles	<b>2</b>	Rotation	<b>Reversible</b>
Resistance Main	<b>.012 Ohms</b>	Mounting	<b>Rigid Base</b>
Motor Orientation	<b>Horizontal</b>	Drive End Bearing	<b>Ball</b>
Opp Drive End Bearing	<b>Ball</b>	Frame Material	<b>Cast Iron</b>
Shaft Type	<b>TS</b>	Overall Length	<b>52.17 in</b>
Shaft Diameter	<b>2.375 in</b>	Shaft Extension	<b>4.75 in</b>
Assembly/Box Mounting	<b>F1/F2 CAPABLE</b>		
Connection Drawing	<b>A-EE7300</b>	Outline Drawing	<b>SS620281-447TS</b>

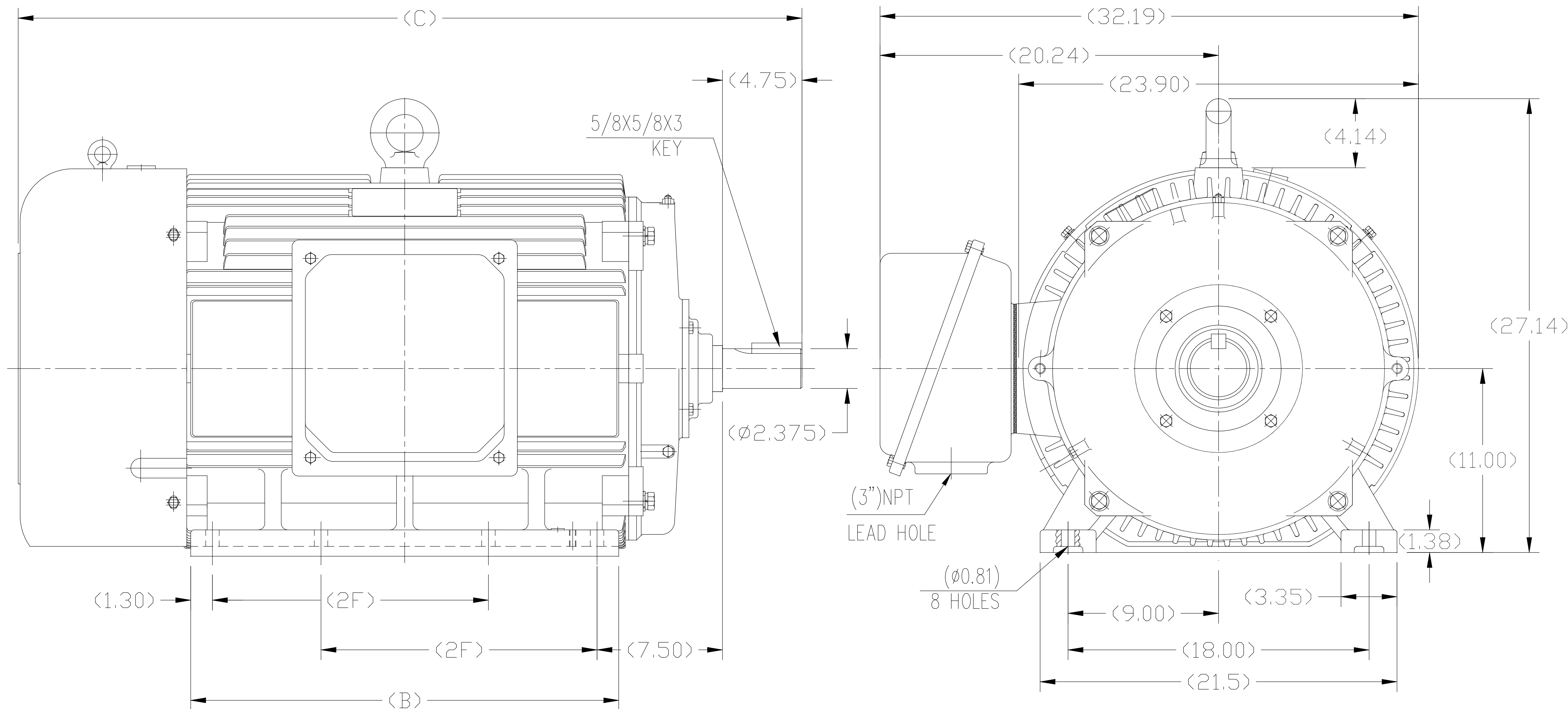

1. THIS MOTOR IS NOT DUAL DRILLED FOR 444T/445T OR 447T/449T
2. THIS MOTOR IS DRILLED FOR F1/F2 CAPABILITY

444TS	47.05	25.60	14.50
445TS	47.05	25.60	16.50
447TS	52.17	30.70	20.00
449TS	52.17	30.70	25.00
Frame	C	BB	2F

				TOLERANCES UNLESS SPECIFIED		REGAL-BELOIT CORPORATION		DRAWN ZYH 02-21-2010			
				DEC.	INCHES			CHK HZJ 02-21-2010			
				.X	±.1	REGAL-BELOIT CORPORATION		APPD CL 02-21-2010			
				.XX	±.03	TITLE		SCALE 1=6			
C	UPDATED DRAWING PER MARK-UP	ECD-0108274	WGJ 10-7-16	EMH	±.005	444/445/447/449TS FR-TEFC CAST IRON		REF			
A	2 leads hole change to 1		CL 2010-9-8		±.0005	MAT'L.		FMF HWADA			
NO.	REVISION		BY & DATE	CHK	ANG	±1/2	FINISH	PREV			
THIS DRAWING IN DESIGN AND DETAIL IS OUR PROPERTY AND MUST NOT BE USED EXCEPT IN CONNECTION WITH OUR WORK ALL RIGHTS OF DESIGN AND INVENTION ARE RESERVED THIS IS AN ELECTRONICALLY GENERATED DOCUMENT - DO NOT SCALE THIS PRINT				RFP			CAD FILE	SS620281	SIZE	DRAWING NO.	REV.
				DIST				B	SS620281	C	

THREE PHASE - SINGLE VOLTAGE  
MOTOR - CONDUIT BOX @ 'A'

TERMINAL BLOCK WHEN SPECIFIED

TO REVERSE ROTATION:  
INTERCHANGE ANY TWO LINE  
LEAD CONNECTIONS



VIEW OF TERMINAL END

**OPTIONAL CORD CONNECTION**

L1	WHITE
L2	RED
L3	BLACK

DRAWING REVISION AC	REVISION BY BS	REV DATE/© DATE 26/07/2022
REQUEST NUMBER CR-0010402	APPROVED BY SN	DATE 26/07/2022
REQUEST NUMBER DESCRIPTION DRAWING UPDATED		
<small>COPYRIGHT (PER REVISION DATE) REGAL BELOIT AMERICA, INC. ALL RIGHTS RESERVED. PROPRIETARY AND CONFIDENTIAL INFORMATION - THIS DOCUMENT IS THE PROPERTY OF REGAL BELOIT AMERICA, INC. ("OWNER") AND CONTAINS OWNER'S PROPRIETARY INFORMATION. ANY PERSON, CORPORATION OR OTHER FIRM RECEIVING IT IS DEEMED, BY RECEIVING IT, TO AGREE THAT IT, AND/OR ANY PART OF IT, SHALL NOT BE DISCLOSED TO ANY PERSON, CORPORATION OR OTHER ENTITY, DUPLICATED, AND/OR USED, EXCEPT AS EXPRESSLY APPROVED IN WRITING IN ADVANCE BY OWNER. THIS DOCUMENT SHALL BE RETURNED TO OWNER UPON REQUEST. IT MAY BE SUBJECT TO CERTAIN RESTRICTIONS UNDER APPLICABLE EXPORT CONTROL LAWS AND REGULATIONS.</small>		

PRIMARY DIMENSIONS ARE INCH  
mm DIMENSIONS IN [BRACKETS]  
ARE FOR REFERENCE ONLY

DRAWN BY DA
DATE 03-26-1993
APPROVED BY TB
DATE 03-26-1993
REFERENCE
THIRD ANGLE PROJECTION

		Regal Beloit America, Inc.	
DESCRIPTION <b>CONNECTION DIAGRAM</b> EXTERNAL - SINGLE VOLTAGE - 3Ø MOTOR			
MATERIAL		PROCESS/FINISH	
SIZE <b>A</b>	DRAWING NUMBER <b>EE7300</b>		SHEET 1 OF 1

**CERTIFICATION DATA SHEET**

**Model#:** 447TSTFC6005 AA **WINDING#:** CHT44720001 NONE 2  
**CONN. DIAGRAM:** A-EE7300 **ASSEMBLY:** F1/F2 CAPABLE  
**OUTLINE:** B-SS620281

**TYPICAL MOTOR PERFORMANCE DATA**

HP	KW	SYNC. RPM	F.L. RPM	FRAME	ENCLOSURE	KVA CODE	DESIGN
200	149	3600	3585	447TS	TEFC	G	B

PH	Hz	VOLTS	FL AMPS	START TYPE	DUTY	INSL	S.F	AMB°C	ELEVATION
3	60	575	172	ACROSS THE LINE	CONTINUOUS	F7	1.15	40	3300

FULL LOAD EFF: 95.4	3/4 LOAD EFF: 95.4	1/2 LOAD EFF: 94.5	GTD. EFF	ELEC. TYPE	NO LOAD AMPS
FULL LOAD PF: 90	3/4 LOAD PF: 89	1/2 LOAD PF: 86	95	SQ CAGE IND RUN	36

F.L. TORQUE	LOCKED ROTOR AMPS	L.R. TORQUE	B.D. TORQUE	F.L. RISE°C
294 LB-FT	1160	625 LB-FT 210	775 LB-FT 262	60

SOUND PRESSURE @ 3 FT.	SOUND POWER	ROTOR WK^2	MAX. WK^2	SAFE STALL TIME	STARTS /HOUR	APPROX. MOTOR WGT
82 dBA	92 dBA	51 LB-FT^2	- LB-FT^2	15 SEC.	-	2850 LBS.

**\*\*\* SUPPLEMENTAL INFORMATION \*\*\***

DE BRACKET TYPE	ODE BRACKET TYPE	MOUNT TYPE	ORIENTATION	SEVERE DUTY	HAZARDOUS LOCATION	DRIP COVER	SCREENS	PAINT
STANDARD	STANDARD	RIGID	HORIZONTAL	FALSE	NONE	FALSE	NONE	BLUE (ENAMEL)

BEARINGS		GREASE	SHAFT TYPE	SPECIAL DE	SPECIAL ODE	SHAFT MATERIAL	FRAME MATERIAL
DE	OPE						
BALL	BALL	POLYREX EM	TS	NONE	NONE	1045 HOT ROLLED (C-204)	CAST IRON
6314	6314						

THERMO-PROTECTORS				THERMISTORS	CONTROL	SPACE /n HEATERS
THERMOSTATS	PROTECTORS	WDG RTDs	BRG RTDs			
NONE	NOT	NONE	NONE	NONE	FALSE	NONE VOLTS

If Inverter equals NONE, contact factory for further information

* N O T E S *	INVERTER TORQUE: NONE
	INV. HP SPEED RANGE: NONE
	ENCODER: NONE NONE NONE NONE NONE PPR
BRAKE: NONE NONE NONE P/N NONE NONE NONE NONE FT-LB NONE V NONE Hz	

DATE: 06/21/2017 06:25:47 AM  
 FORM 3531 REV.3 02/07/99  
 \*\* Subject to change without notice.

Data Sheet

Date: 15-06-2017  
 Customer: \_\_\_\_\_  
 Attention: \_\_\_\_\_  
 Submitted by: FAREEDA DUDEKULA



447TSTFC6005

Submittal

Data @ 575 V

Motor Load Data

Load	0%	25%	50%	75%	100%	115%	125%	LR
Current (Amps)	36.0	55.2	91.2	132	172	198	216	1,160
Torque (ft-lb)	0.00	73.0	146	220	294	338	368	625
RPM	3600	3595	3592	3588	3585	3,582	3578	0
Efficiency (%)		91.7	94.5	95.4	95.4	95.4	95.0	
P.F. (%)	9.0	74.0	86.0	89.0	90.0	90.5	90.5	32.0

Motor Speed Data

	LR	Pull-Up	BD	Rated	Idle
Speed (RPM)	0	1800	3475	3585	3600
Current (Amps)	1,160	1,040	680	172	36.0
Torque (ft-lb)	625	450	775	294	0.00

Information Block				
HP	200.0			
Sync. RPM	3600			
Frame	449			
Enclosure	TEFC			
Construction	TFC			
Voltage	575 V			
Frequency	60 Hz			
Design	A			
LR Code letter	G			
Service Factor	1.15			
Temp Rise @ FL	60 ° C			
Duty	CONT			
Ambient	40 ° C			
Elevation	1,000 feet			
Rotor/Shaft wk <sup>2</sup>	51.0 Lb-Ft <sup>2</sup>			
Ref Wdg	CHT44720001 NONE			
Sound Pressure @ 1M	82 dBA			
VFD Rating	NONE			
Outline Dwg	B-SS620281			
Conn. Diag	A-EE7300			
Additional Specifications:				
0				
365THFS8036				
EQUIV CKT (OHMS / PHASE)				
R1	R2	X1	X2	Xm
0.0150	0.0090	0.1390	0.2600	9.4410

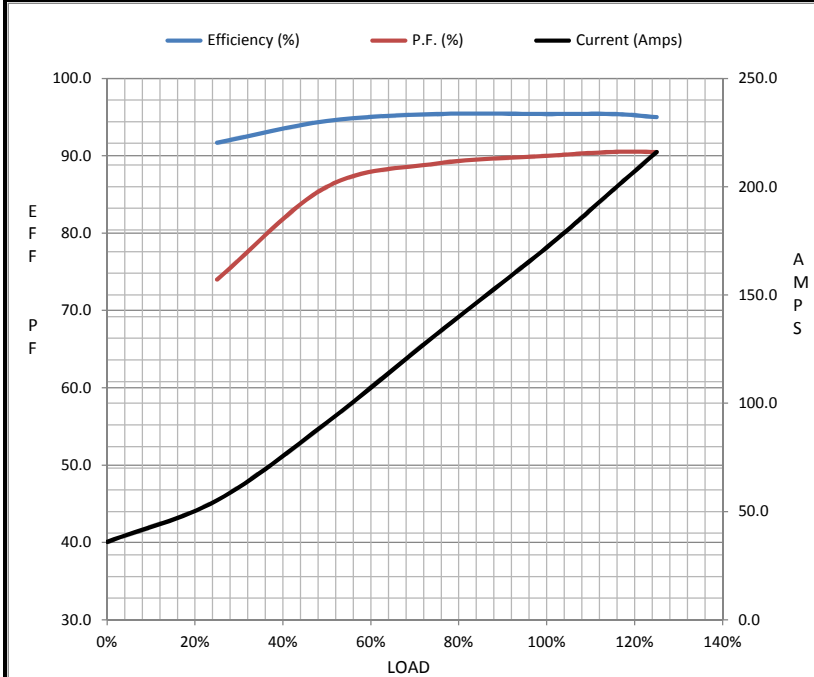

Speed - Torque Curve

