

PRODUCT INFORMATION PACKET

Model No: 445TSTFN4026

Catalog No: E811

Other Purpose Motor, 150 HP, 3 Ph, 60 Hz, 460 V, 1800 RPM, 445TS Frame, TEFC

Regal and are trademarks of Regal Rexnord Corporation or one of its affiliated companies.
©2022 Regal Rexnord Corporation, All Rights Reserved. MC017097E



Nameplate Specifications

Output HP	150 Hp	Output KW	112.0 kW
Frequency	60 Hz	Voltage	460 V
Current	172.0 A	Speed	1785 rpm
Service Factor	1.15	Phase	3
Efficiency	95 %	Power Factor	86
Duty	Continuous	Insulation Class	F
Design Code	B	KVA Code	G
Frame	445TS	Enclosure	Totally Enclosed Fan Cooled
Thermal Protection	No Protection	Ambient Temperature	40 °C
Drive End Bearing Size	6313	Opp Drive End Bearing Size	6313
UL	Recognized	CSA	Y
CE	Y	IP Code	43
Number of Speeds	1		

Technical Specifications

Electrical Type	Squirrel Cage Induction Run	Starting Method	Across The Line
Poles	4	Rotation	Reversible
Resistance Main	.027 Ohms	Mounting	Rigid Base
Motor Orientation	Horizontal	Drive End Bearing	Ball
Opp Drive End Bearing	Ball	Frame Material	Cast Iron
Shaft Type	TS	Overall Length	39.60 in
Frame Length	20.25 in	Shaft Diameter	2.375 in
Shaft Extension	5 in	Assembly/Box Mounting	F1/F2 CAPABLE
Outline Drawing	B-SS514023-2025	Connection Drawing	A-EE7300U

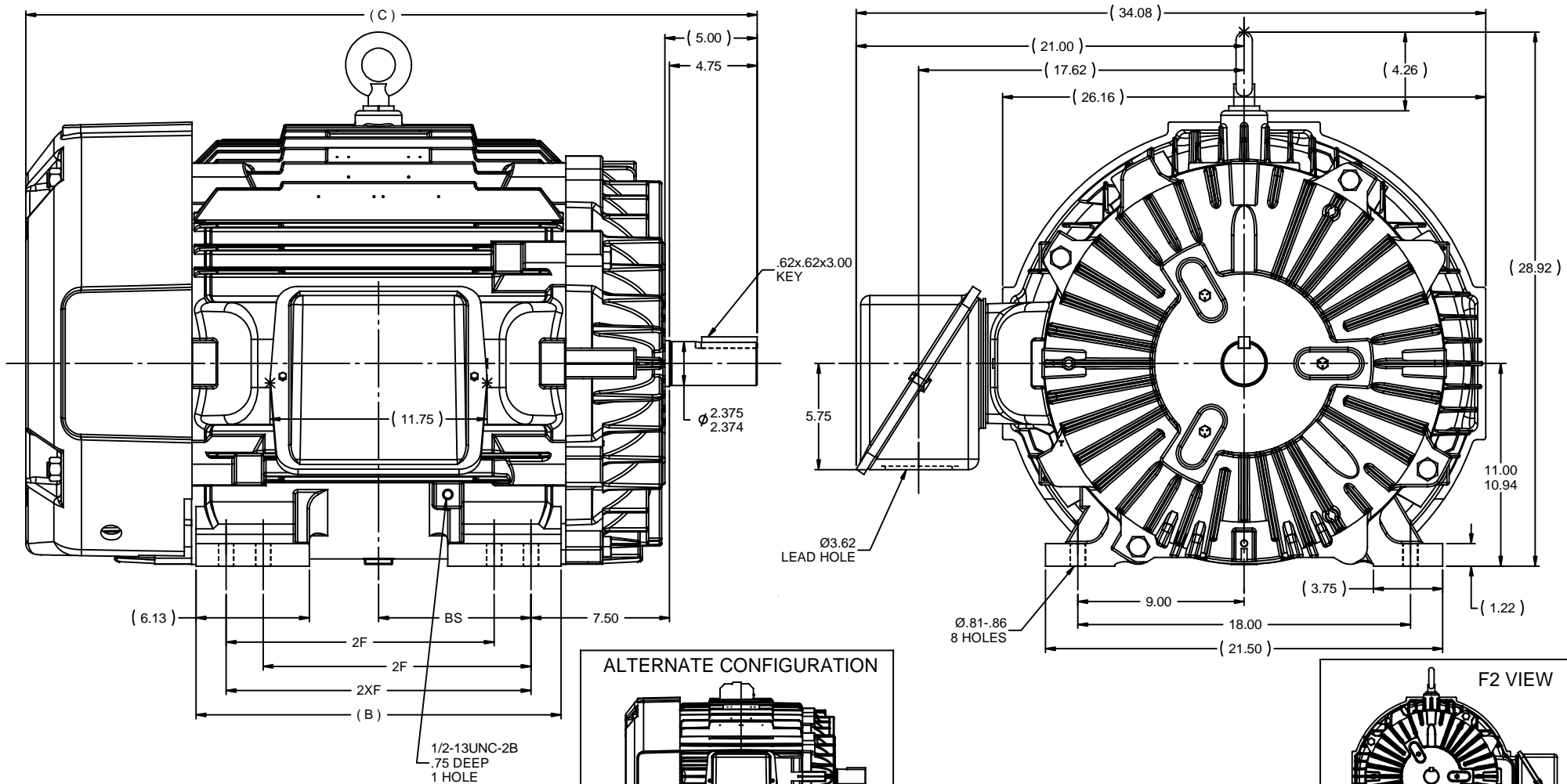

- NOTES:
 1. CONDUIT BOX CAN BE ROTATED IN 90° STEPS.
 2. CONDUIT BOX CAN BE MOUNTED ON OPPOSITE SIDE BY REMOVING BRACKETS AND TURNING FRAME 180°.
 3. NAMEPLATES TO BE READ FROM CONDUIT BOX SIDE OF MOTOR.

10	CORRECTED C'BOX DIM. 5.75 WAS 5.56 ISAAC 09-5049	JJB 2/4/2011		TOLERANCES UNLESS SPECIFIED						
9	UPDATED WITH NEW FRAME. 28.92 DIMENSION WAS 26.52.			DEC	INCHES					
	ADDED PREVIOUS CONFIG. & F2 VIEW PER ISAAC 09-5049	JJB 12/16/2008	MH	x	±.1					
8	CHG. FAN GUARD & REV. C DIM. PER CN 39335	RWR 01/22/2007	ML	XX	±.03	TITLE	OUTLINE		SCALE 1:5.25	
7	REVISED LEAD DIM FROM Ø4.12 PER CN 32179	CTO 03/24/2003	ML	XXX	±.005		444/445TS FR. - TEFC - STD.		REF	
6	REISSUE - 26.52 DIMENSION WAS 24.19 CN 21946	KL 05/19/1999		XXXX	±.0005	MATL			FMF	
NO	REVISION	BY & DATE	CHK	ANG	±1/2°	FINISH			PAGE OF	
	THIRD ANGLE PROJECTION		RFP	06-25-1991	PREV			SIZE	DRAWING NO	REV
			NETWORK FILE NAME	SS514023				B	SS514023	10

DASH	FRAME	B	C	2F	2XF	BS
1825	444TS	17.75	37.60	14.50	---	7.25
2025	444/445TS	19.75	39.60	14.50	16.50	8.25

IF MOTOR HAS 9 LEADS



IF MOTOR HAS 6 LEADS



A-9806 DECAL IF CALLED FOR

IF MOTOR HAS 12 LEADS

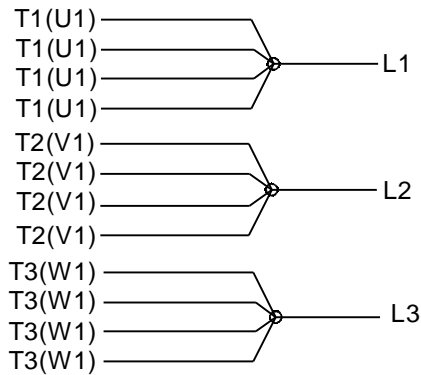

VIEW OF TERMINAL END

DRAWING REVISION L	REVISION BY AJW	DATE 05-04-2015	TOLERANCES UNLESS OTHERWISE SPECIFIED:	DRAWN BY DRS	Regal Beloit America, Inc.																					
ECO ECO-0077067	APPROVED BY EWH	DATE 05-05-2015	<table style="font-size: small; border-collapse: collapse;"> <tr> <td><u>DEC.</u></td> <td><u>INCH</u></td> <td><u>mm</u></td> <td><u>ANGLE</u></td> </tr> <tr> <td>.X</td> <td>±0.1</td> <td>[±2.5]</td> <td>±7' 30"</td> </tr> <tr> <td>.XX</td> <td>±0.02</td> <td>[±0.51]</td> <td></td> </tr> <tr> <td>.XXX</td> <td>±0.005</td> <td>[±0.127]</td> <td></td> </tr> <tr> <td>.XXXX</td> <td>±0.0005</td> <td>[±0.0127]</td> <td></td> </tr> </table>	<u>DEC.</u>			<u>INCH</u>	<u>mm</u>	<u>ANGLE</u>	.X	±0.1	[±2.5]	±7' 30"	.XX	±0.02	[±0.51]		.XXX	±0.005	[±0.127]		.XXXX	±0.0005	[±0.0127]		DATE 09-27-1996
<u>DEC.</u>	<u>INCH</u>	<u>mm</u>	<u>ANGLE</u>																							
.X	±0.1	[±2.5]	±7' 30"																							
.XX	±0.02	[±0.51]																								
.XXX	±0.005	[±0.127]																								
.XXXX	±0.0005	[±0.0127]																								
ECO DESCRIPTION UPDATED TO SOLIDWORKS <small>COPYRIGHT REGAL BELOIT AMERICA, INC. ALL RIGHTS RESERVED. PROPRIETARY AND CONFIDENTIAL INFORMATION - THIS DOCUMENT IS THE PROPERTY OF REGAL BELOIT AMERICA, INC. ("OWNER") AND CONTAINS OWNER'S PROPRIETARY INFORMATION. ANY PERSON, CORPORATION OR OTHER FIRM RECEIVING IT IS DEEMED, BY RECEIVING IT, TO AGREE THAT IT, AND/OR ANY PART OF IT, SHALL NOT BE DISCLOSED TO ANY PERSON, CORPORATION OR OTHER ENTITY, DUPLICATED, AND/OR USED, EXCEPT AS EXPRESSLY APPROVED IN WRITING IN ADVANCE BY OWNER. THIS DOCUMENT SHALL BE RETURNED TO OWNER UPON REQUEST. IT MAY BE SUBJECT TO CERTAIN RESTRICTIONS UNDER APPLICABLE EXPORT CONTROL LAWS AND REGULATIONS.</small>			APPROVED BY GK	MATERIAL _____ PROCESS/FINISH _____																						
			DATE 09-30-1996			REFERENCE	SIZE A	DRAWING NUMBER EE7300U	SHEET 1 OF 1																	
			REMOVE BURRS & BREAK SHARP EDGES: .003/.015 [.076/.381] X 45° CORNER FILLETS: R.02 [.51] MACHINED SURFACES: 200 $\sqrt{\text{INCH}}$ 5.1 $\sqrt{\text{mm}}$ mm SHOWN IN [BRACKETS]	THIRD ANGLE PROJECTION																						