

PRODUCT INFORMATION PACKET

Model No: 445TSTFC6001

Catalog No: GT1051

Globetrotter® General Purpose Motor, 150 & 125 HP, 3 Ph, 60 & 50 Hz, 460 & 380 V, 3600 & 3000 RPM,
445TS Frame, TEFC



Regal and Marathon are trademarks of Regal Rexnord Corporation or one of its affiliated companies.

©2023 Regal Rexnord Corporation, All Rights Reserved. MC017097E

Nameplate Specifications

Phase	3	Output HP	150 & 125 Hp
Output KW	112.0 & 93.0 kW	Voltage	460 & 380 V
Speed	3580 & 2980 rpm	Service Factor	1.15 & 1.15
Frame	445TS	Enclosure	Totally Enclosed Fan Cooled
Thermal Protection	No Protection	Efficiency	95 & 94.5 %
Ambient Temperature	40 °C	Frequency	60 & 50 Hz
Current	162 & 165 A	Power Factor	90
Duty	Continuous	Insulation Class	F
Design Code	B	KVA Code	G
Drive End Bearing Size	6314	Opp Drive End Bearing Size	6314
UL	Recognized	CSA	Y
CE	Y	IP Code	43
Number of Speeds	1		

Technical Specifications

Electrical Type	Squirrel Cage Inverter Rated	Starting Method	Part Wdg Start Or Inverter
Poles	2	Rotation	Reversible
Resistance Main	.018 Ohms	Mounting	Rigid Base
Motor Orientation	Horizontal	Drive End Bearing	Ball
Opp Drive End Bearing	Ball	Frame Material	Cast Iron
Shaft Type	TS	Overall Length	47.05 in
Shaft Diameter	2.375 in	Shaft Extension	4.75 in
Assembly/Box Mounting	F1/F2 CAPABLE	Inverter Load	VARIABLE 10:1
Outline Drawing	SS620281-445TS	Connection Drawing	A-EE7341C

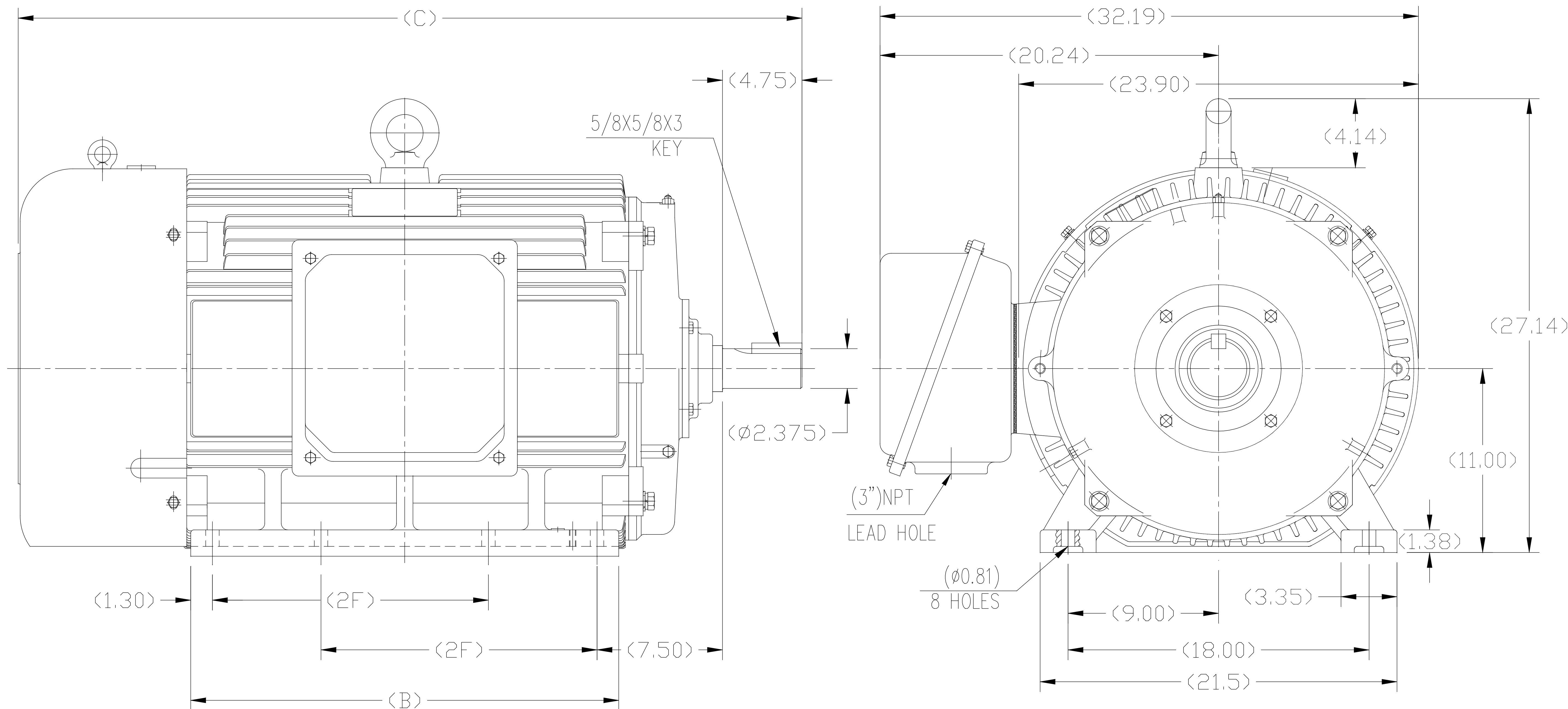

1. THIS MOTOR IS NOT DUAL DRILLED FOR 444T/445T OR 447T/449T
2. THIS MOTOR IS DRILLED FOR F1/F2 CAPABILITY

444TS	47.05	25.60	14.50
445TS	47.05	25.60	16.50
447TS	52.17	30.70	20.00
449TS	52.17	30.70	25.00
Frame	C	BB	2F

				TOLERANCES UNLESS SPECIFIED		REGAL-BELOIT CORPORATION		DRAWN ZYH 02-21-2010		
				DEC.	INCHES			CHK HZJ 02-21-2010		
				.X	±.1			APPD CL 02-21-2010		
				.XX	±.03	TITLE		SCALE 1=6		
C	UPDATED DRAWING PER MARK-UP	ECD-0108274	WGJ 10-7-16	EMH	±.005	444/445/447/449TS FR-TEFC CAST IRON		REF		
A	2 leads hole change to 1		CL 2010-9-8		±.0005	MAT'L.		FMF HWADA		
NO.	REVISION		BY & DATE	CHK	ANG	±1/2	FINISH	PREV		
THIS DRAWING IN DESIGN AND DETAIL IS OUR PROPERTY AND MUST NOT BE USED EXCEPT IN CONNECTION WITH OUR WORK ALL RIGHTS OF DESIGN AND INVENTION ARE RESERVED THIS IS AN ELECTRONICALLY GENERATED DOCUMENT - DO NOT SCALE THIS PRINT				RFP	CAD FILE		SS620281	SIZE	DRAWING NO.	REV.
				DIST			B	SS620281	C	

EE7341C

THREE PHASE – PART WINDING START
DELTA – 6 LEADS

START

CONNECT T1 TO LINE 1
CONNECT T2 TO LINE 2
CONNECT T3 TO LINE 3
T7-T8-T9 OPEN

RUN

CONNECT T1&T7 TO LINE 1
CONNECT T2&T8 TO LINE 2
CONNECT T3&T9 TO LINE 3

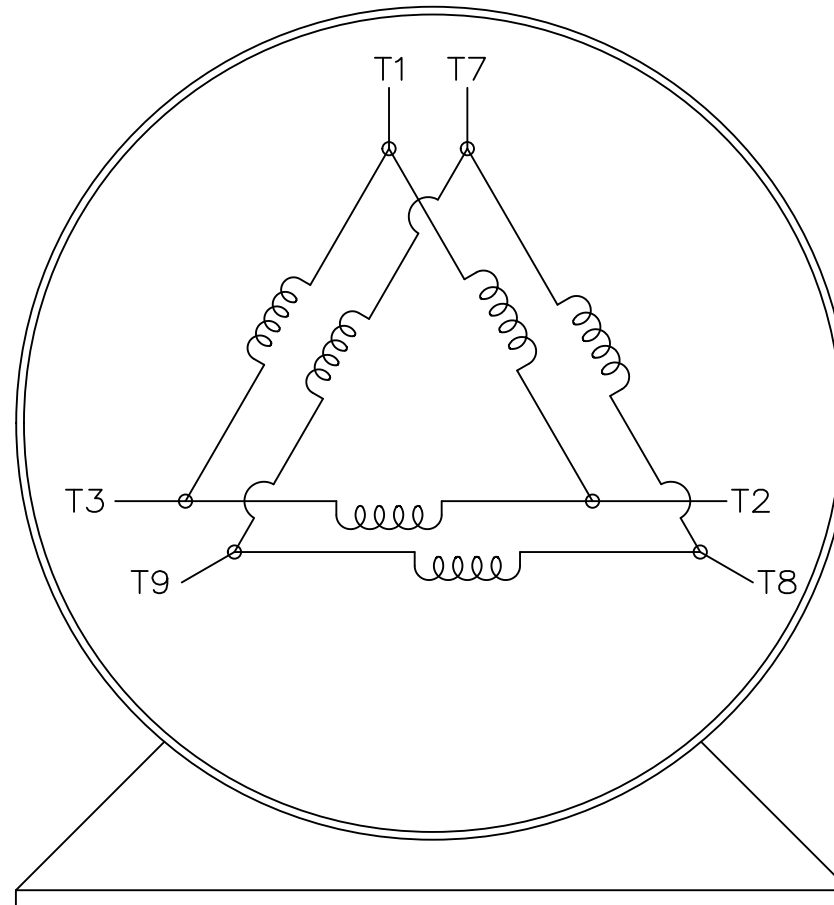

VIEW OF TERMINAL END

IF MOTOR HAS 2 T'S

START

CONNECT T1,T1 TO LINE 1
CONNECT T2,T2 TO LINE 2
CONNECT T3,T3 TO LINE 3
T7,T7-T8,T8-T9,T9 OPEN

RUN

CONNECT T1,T1&T7,T7 TO LINE 1
CONNECT T2,T2&T8,T8 TO LINE 2
CONNECT T3,T3&T9,T9 TO LINE 3

		TOLERANCES UNLESS SPECIFIED		REGAL REGAL-BELOIT CORPORATION		DRAWN	BLR	03-09-1998
		DEC.	INCHES			CHK	ML	03-23-1998
		.X	± -			APPD	GK	03-23-1998
		.XX	± -	TITLE		SCALE 1=1		
E	NOTE ADDED FOR 2 T'S	NAR 17-12-2020	RC	.XXX	± -	CONNECTION DIAGRAM		REF
D	RE-DRAWN WITH REGAL LOGO ECO-0110493	WGJ 09-30-2016	EMH	.XXXX	± -	3ø - 6 LEADS		FMF
NO.	REVISION	BY & DATE	CHK	ANG	± -	FINISH		PREV
THIS DRAWING IN DESIGN AND DETAIL IS OUR PROPERTY AND MUST NOT BE USED EXCEPT IN CONNECTION WITH OUR WORK ALL RIGHTS OF DESIGN AND INVENTION ARE RESERVED THIS IS AN ELECTRONICALLY GENERATED DOCUMENT - DO NOT SCALE THIS PRINT				RFP	CAD FILE EE7341C		SIZE	DRAWING NO. PAGE OF REV.
				DIST			A	EE7341C E

CERTIFICATION DATA SHEET

Model#: 445TSTFC6001 AB **WINDING#:** CHT44520001 NONE 1
CONN. DIAGRAM: A-EE7341C **ASSEMBLY:** F1/F2 CAPABLE
OUTLINE: B-SS620281

TYPICAL MOTOR PERFORMANCE DATA

HP	KW	SYNC. RPM	F.L. RPM	FRAME	ENCLOSURE	KVA CODE	DESIGN
150&125	112&93	3600	3580&2980	445TS	TEFC	G	B

PH	Hz	VOLTS	FL AMPS	START TYPE	DUTY	INSL	S.F	AMB°C	ELEVATION
3	60/50	460#380	162&165	PWS OR INVERTER	CONTINUOUS	F7	1.15/1.15	40	3300

FULL LOAD EFF: 95&94.5	3/4 LOAD EFF: 95	1/2 LOAD EFF: 94.1	GTD. EFF	ELEC. TYPE	NO LOAD AMPS
FULL LOAD PF: 90&90	3/4 LOAD PF: 89	1/2 LOAD PF: 87	94.5	SQ CAGE INV RATED	33

F.L. TORQUE	LOCKED ROTOR AMPS	L.R. TORQUE	B.D. TORQUE	F.L. RISE°C
220 LB-FT	1085	475 LB-FT 215	550 LB-FT 252	55

SOUND PRESSURE @ 3 FT.	SOUND POWER	ROTOR WK^2	MAX. WK^2	SAFE STALL TIME	STARTS /HOUR	APPROX. MOTOR WGT
82 dBA	92 dBA	44 LB-FT^2	120 LB-FT^2	15 SEC.	2	2750 LBS.

***** SUPPLEMENTAL INFORMATION *****

DE BRACKET TYPE	ODE BRACKET TYPE	MOUNT TYPE	ORIENTATION	SEVERE DUTY	HAZARDOUS LOCATION	DRIP COVER	SCREENS	PAINT
STANDARD	STANDARD	RIGID	HORIZONTAL	FALSE	NONE	FALSE	NONE	BLUE (ENAMEL)

BEARINGS		GREASE	SHAFT TYPE	SPECIAL DE	SPECIAL ODE	SHAFT MATERIAL	FRAME MATERIAL
DE	OPE						
BALL	BALL	POLYREX EM	TS	NONE	NONE	1045 HOT ROLLED (C-204)	CAST IRON
6314	6314						

THERMO-PROTECTORS				THERMISTORS	CONTROL	SPACE /n HEATERS
THERMOSTATS	PROTECTORS	WDG RTDs	BRG RTDs			
NONE	NOT	NONE	NONE	NONE	FALSE	NONE VOLTS

If Inverter equals NONE, contact factory for further information

*
N
O
T
E
S
*

INVERTER TORQUE: VARIABLE 10:1
INV. HP SPEED RANGE: NONE
ENCODER: NONE
NONE NONE
NONE NONE PPR
BRAKE: NONE NONE
NONE P/N NONE
NONE NONE
NONE FT-LB NONE V NONE Hz

DATE: 06/21/2017 05:23:47 AM
 FORM 3531 REV.3 02/07/99
 ** Subject to change without notice.

Data Sheet

Date: 29-06-2017
Customer: _____
Attention: _____
Submitted by: FAREEDA DUDEKULA



445STFC6001

Submittal

Data @ **460 V**

Motor Load Data

Load	0%	25%	50%	75%	100%	115%	125%	LR
Current (Amps)	33.0	52.5	86.0	124	162	186	204	1,085
Torque (ft-lb)	0.00	55.0	110	165	220	254	276	475
RPM	3600	3595	3590	3585	3580	3,578	3575	0
Efficiency (%)		90.2	94.1	95.0	95.0	95.0	94.5	
P.F. (%)	10.0	74.0	87.0	89.0	90.0	90.0	90.0	35.0

Motor Speed Data

	LR	Pull-Up	BD	Rated	Idle
Speed (RPM)	0	1800	3475	3580	3600
Current (Amps)	1,085	950	600	162	33.0
Torque (ft-lb)	475	400	550	220	0.00

Information Block

HP	150.0			
Sync. RPM	3600			
Frame	445			
Enclosure	TEFC			
Construction	TFC			
Voltage	460#380 V			
Frequency	60 Hz			
Design	A			
LR Code letter	G			
Service Factor	1.15			
Temp Rise @ FL	55 ° C			
Duty	CONT			
Ambient	40 ° C			
Elevation	1,000 feet			
Rotor/Shaft wk ²	44.0 Lb-Ft ²			
Ref Wdg	CHT44520001 NONE			
Sound Pressure @ 1M	82 dBA			
VFD Rating	VARIABLE 10:1			
Outline Dwg	B-SS620281			
Conn. Diag	A-EE7341C			
Additional Specifications:				
0				
365THFS8036				
EQUIV CKT (OHMS / PHASE)				
R1	R2	X1	X2	Xm
0.0140	0.0130	0.1660	0.1400	5.1600

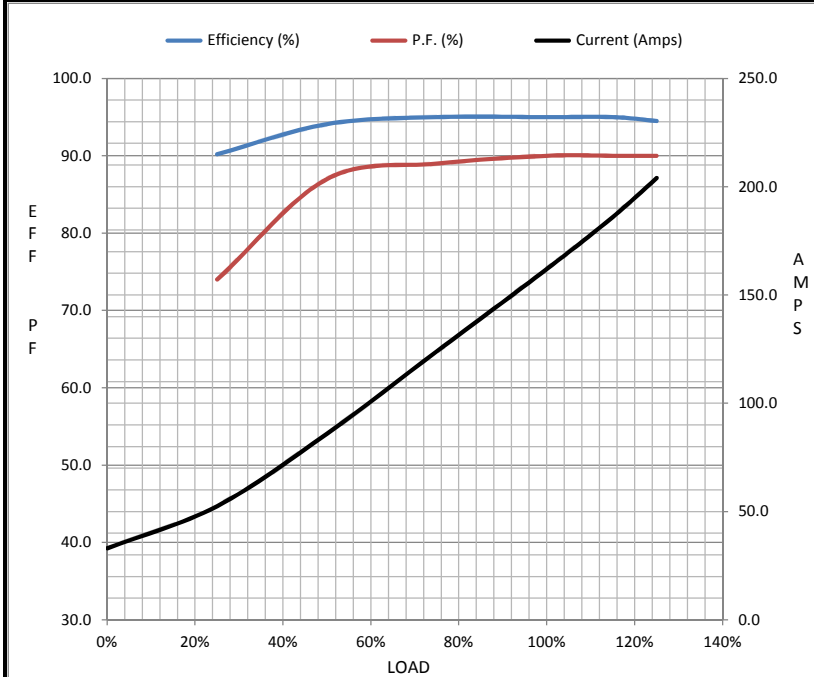

Speed - Torque Curve

