

# PRODUCT INFORMATION PACKET

**marathon**<sup>®</sup>  
Motors

Model No: 445TSTDS7362

Catalog No: H192

250 HP General Purpose Motor, 3 phase, 1800 RPM, 460 V, 445TS Frame, ODP  
General Purpose Motors

Regal and Marathon are trademarks of Regal Rexnord Corporation or one of its affiliated companies.  
©2021 Regal Rexnord Corporation, All Rights Reserved. MC017097E

The logo for Regal Rexnord, featuring a stylized 'R' icon followed by the text 'RegalRexnord'.



### Nameplate Specifications

Output HP	<b>250 Hp</b>	Output KW	<b>187.0 kW</b>
Frequency	<b>60 Hz</b>	Voltage	<b>460 V</b>
Current	<b>287.0 A</b>	Speed	<b>1780 rpm</b>
Service Factor	<b>1.15</b>	Phase	<b>3</b>
Efficiency	<b>95 %</b>	Power Factor	<b>86</b>
Duty	<b>Continuous</b>	Insulation Class	<b>B</b>
Design Code	<b>B</b>	KVA Code	<b>F</b>
Frame	<b>445TS</b>	Enclosure	<b>Drip Proof</b>
Thermal Protection	<b>No</b>	Ambient Temperature	<b>40 °C</b>
Drive End Bearing Size	<b>6313</b>	Opp Drive End Bearing Size	<b>6313</b>
UL	<b>Recognized</b>	CSA	<b>Y</b>
CE	<b>Y</b>	IP Code	<b>12</b>
Number of Speeds	<b>1</b>		

### Technical Specifications

Electrical Type	<b>Squirrel Cage Induction Run</b>	Starting Method	<b>Across The Line</b>
Poles	<b>4</b>	Rotation	<b>Reversible</b>
Resistance Main	<b>0.021 Ohms</b>	Mounting	<b>Rigid Base</b>
Motor Orientation	<b>Horizontal</b>	Drive End Bearing	<b>Ball</b>
Opp Drive End Bearing	<b>Ball</b>	Frame Material	<b>Cast Iron</b>
Shaft Type	<b>TS</b>	Overall Length	<b>36.00 in</b>
Frame Length	<b>20.50 in</b>	Shaft Diameter	<b>2.380 in</b>
Shaft Extension	<b>5 in</b>	Assembly/Box Mounting	<b>F1/F2 Capable</b>
Connection Drawing	<b>A-EE7300U</b>	Outline Drawing	<b>B-SS509642-2050</b>

This is an uncontrolled document once printed or downloaded and is subject to change without notice. Date Created:10/12/2021

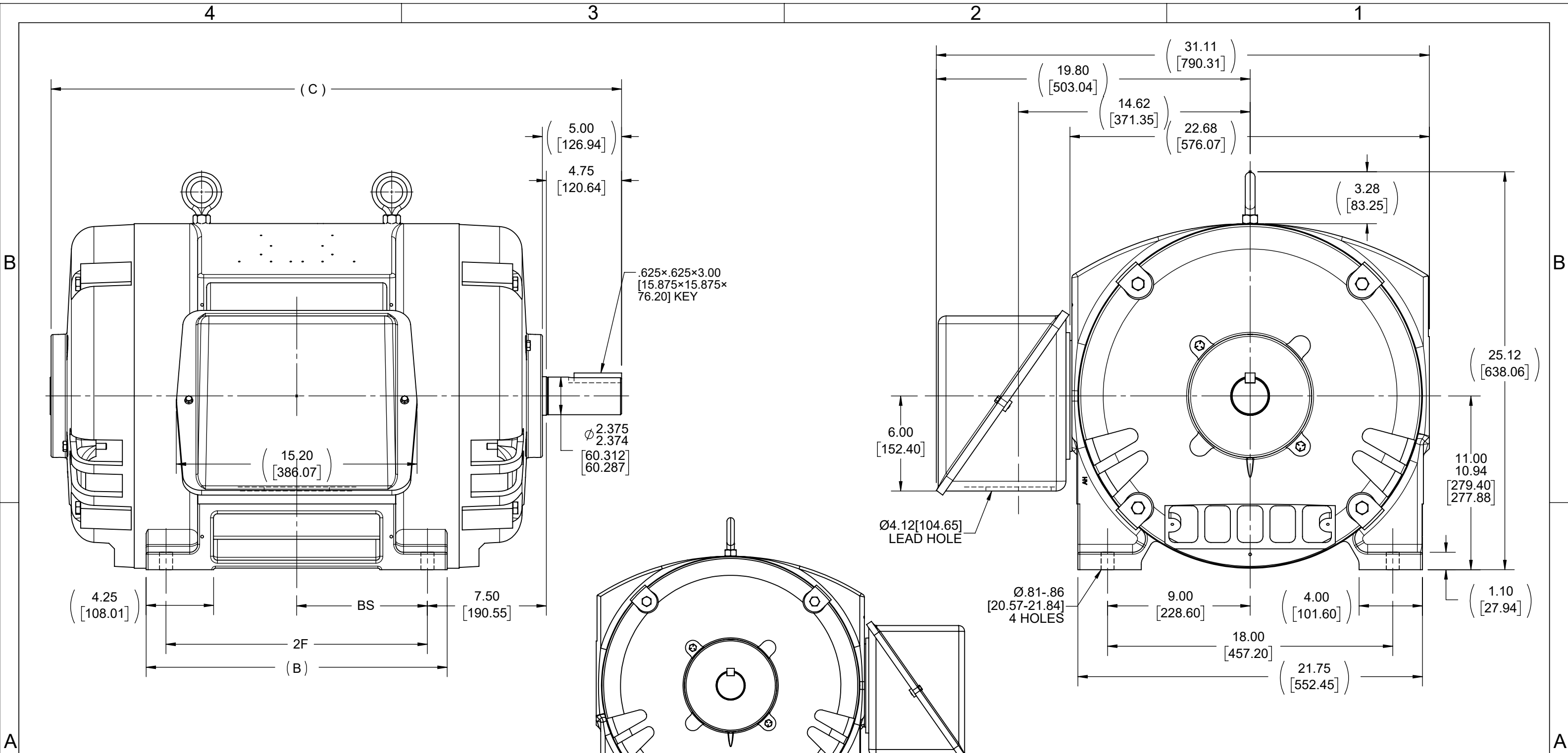

- NOTES:  
 1. CONDUIT BOX CAN BE ROTATED IN 90° STEPS.  
 2. CONDUIT BOX CAN BE MOUNTED ON OPPOSITE SIDE BY REMOVING BRACKETS AND TURNING FRAME 180°.  
 3. NAMEPLATES TO BE READ FROM CONDUIT BOX SIDE OF MOTOR.

DASH	FRAME	B	C	2F	BS
1850	444TS	17.00 [431.80]	34.00 [863.60]	14.50 [368.30]	7.25 [184.15]
2050	445TS	19.00 [482.60]	36.00 [914.40]	16.50 [419.10]	8.25 [209.55]

DRAWING REVISION D	REVISION BY A. KEETHA	DATE 10-01-2021
ECO NMR-0210542	APPROVED BY A. KEETHA	DATE 10-01-2021
ECO DESCRIPTION F2 VIEW ADDED		
<small>COPYRIGHT REGAL BELOIT AMERICA, INC. ALL RIGHTS RESERVED.          PROPRIETARY AND CONFIDENTIAL INFORMATION - THIS DOCUMENT IS THE PROPERTY OF          REGAL BELOIT AMERICA, INC. ("OWNER") AND CONTAINS OWNER'S PROPRIETARY          INFORMATION. ANY PERSON, CORPORATION OR OTHER FIRM RECEIVING IT IS DEEMED,          BY RECEIVING IT, TO AGREE THAT IT, AND/OR ANY PART OF IT, SHALL NOT BE DISCLOSED          TO ANY PERSON, CORPORATION OR OTHER ENTITY, DUPLICATED, AND/OR USED, EXCEPT          AS EXPRESSLY APPROVED IN WRITING IN ADVANCE BY OWNER. THIS DOCUMENT SHALL          BE RETURNED TO OWNER UPON REQUEST. IT MAY BE SUBJECT TO CERTAIN          RESTRICTIONS UNDER APPLICABLE EXPORT CONTROL LAWS AND REGULATIONS.</small>		

TOLERANCES UNLESS OTHERWISE SPECIFIED:

DEC.	INCH	mm	ANGLE
.X	±0.1	[±2.5]	±7° 30"
.XX	±0.03	[±0.76]	
.XXX	±0.005	[±0.127]	
.XXXX	±0.0005	[±0.0127]	

REMOVE BURRS & BREAK SHARP EDGES: .003/.015 [0.076/.381] X 45°  
 CORNER FILLETS: R.02 [0.51]  
 MACHINED SURFACES: 200 INCH 5.1 mm

mm SHOWN IN [BRACKETS]

DRAWN BY TLB	Regal Beloit America, Inc.
DATE 03-11-1988	
APPROVED BY GK	
DATE 03-11-1988	
REFERENCE	DESCRIPTION OUTLINE 444/445TS FR. - DR. PR. STD.
THIRD ANGLE PROJECTION	MATERIAL
SIZE B	DRAWING NUMBER SS509642
	SHEET 1 OF 1

**IF MOTOR HAS 9 LEADS**



**IF MOTOR HAS 6 LEADS**



A-9806 DECAL IF CALLED FOR

**IF MOTOR HAS 12 LEADS**

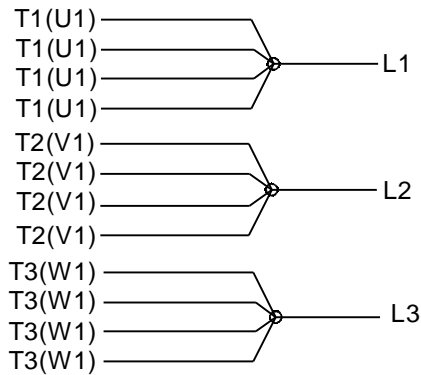

**VIEW OF TERMINAL END**

DRAWING REVISION <b>L</b>	REVISION BY <b>AJW</b>	DATE <b>05-04-2015</b>	TOLERANCES UNLESS OTHERWISE SPECIFIED:	DRAWN BY <b>DRS</b>	<b>Regal Beloit America, Inc.</b>																					
ECO <b>ECO-0077067</b>	APPROVED BY <b>EWH</b>	DATE <b>05-05-2015</b>	<table style="font-size: small; border-collapse: collapse;"> <tr> <td><u>DEC.</u></td> <td><u>INCH</u></td> <td><u>mm</u></td> <td><u>ANGLE</u></td> </tr> <tr> <td>.X</td> <td>±0.1</td> <td>[±2.5]</td> <td>±7' 30"</td> </tr> <tr> <td>.XX</td> <td>±0.02</td> <td>[±0.51]</td> <td></td> </tr> <tr> <td>.XXX</td> <td>±0.005</td> <td>[±0.127]</td> <td></td> </tr> <tr> <td>.XXXX</td> <td>±0.0005</td> <td>[±0.0127]</td> <td></td> </tr> </table>	<u>DEC.</u>			<u>INCH</u>	<u>mm</u>	<u>ANGLE</u>	.X	±0.1	[±2.5]	±7' 30"	.XX	±0.02	[±0.51]		.XXX	±0.005	[±0.127]		.XXXX	±0.0005	[±0.0127]		DATE <b>09-27-1996</b>
<u>DEC.</u>	<u>INCH</u>	<u>mm</u>	<u>ANGLE</u>																							
.X	±0.1	[±2.5]	±7' 30"																							
.XX	±0.02	[±0.51]																								
.XXX	±0.005	[±0.127]																								
.XXXX	±0.0005	[±0.0127]																								
ECO DESCRIPTION <b>UPDATED TO SOLIDWORKS</b>			APPROVED BY <b>GK</b>	DATE <b>09-30-1996</b>	MATERIAL	PROCESS/FINISH																				
COPYRIGHT REGAL BELOIT AMERICA, INC. ALL RIGHTS RESERVED. PROPRIETARY AND CONFIDENTIAL INFORMATION - THIS DOCUMENT IS THE PROPERTY OF REGAL BELOIT AMERICA, INC. ("OWNER") AND CONTAINS OWNER'S PROPRIETARY INFORMATION. ANY PERSON, CORPORATION OR OTHER FIRM RECEIVING IT IS DEEMED, BY RECEIVING IT, TO AGREE THAT IT, AND/OR ANY PART OF IT, SHALL NOT BE DISCLOSED TO ANY PERSON, CORPORATION OR OTHER ENTITY, DUPLICATED, AND/OR USED, EXCEPT AS EXPRESSLY APPROVED IN WRITING IN ADVANCE BY OWNER. THIS DOCUMENT SHALL BE RETURNED TO OWNER UPON REQUEST. IT MAY BE SUBJECT TO CERTAIN RESTRICTIONS UNDER APPLICABLE EXPORT CONTROL LAWS AND REGULATIONS.			REMOVE BURRS & BREAK SHARP EDGES: .003/.015 [.076/.381] X 45° CORNER FILLETS: R.02 [.51] MACHINED SURFACES: 200 $\sqrt{\text{INCH}}$ 5.1 $\sqrt{\text{mm}}$	REFERENCE	SIZE <b>A</b>	DRAWING NUMBER <b>EE7300U</b>	SHEET <b>1 OF 1</b>																			
			mm SHOWN IN [BRACKETS]	THIRD ANGLE PROJECTION																						