

PRODUCT INFORMATION PACKET

Model No: 444TTFN16577

Catalog No: E327

Severe Duty Motors, TEFC, 100 HP, 3 Ph, 60 Hz, 460 V, 1188 RPM, 444T Frame



Regal and are trademarks of Regal Rexnord Corporation or one of its affiliated companies.
©2022 Regal Rexnord Corporation, All Rights Reserved. MC017097E

Nameplate Specifications

Output HP	100 Hp	Output KW	75.0 kW
Frequency	60 Hz	Voltage	460 V
Current	124.0 A	Speed	1188 rpm
Service Factor	1.15	Phase	3
Efficiency	95 %	Power Factor	80
Duty	Continuous	Insulation Class	F
Design Code	B	KVA Code	G
Frame	444T	Enclosure	Totally Enclosed Fan Cooled
Thermal Protection	No Protection	Ambient Temperature	40 °C
Drive End Bearing Size	6318	Opp Drive End Bearing Size	6316
UL	Recognized	CSA	Y
CE	Y	IP Code	54
Number of Speeds	1		

Technical Specifications

Electrical Type	Squirrel Cage Inverter Rated	Starting Method	Line Or Inverter
Poles	6	Rotation	Reversible
Resistance Main	.048 Ohms	Mounting	Rigid Base
Motor Orientation	Horizontal	Drive End Bearing	Ball
Opp Drive End Bearing	Ball	Frame Material	Cast Iron
Shaft Type	T	Overall Length	41.35 in
Frame Length	18.25 in	Shaft Diameter	3.375 in
Shaft Extension	8.75 in	Assembly/Box Mounting	F1/F2 Capable
Connection Drawing	A-EE7300U	Outline Drawing	B-SS519971-1825

This is an uncontrolled document once printed or downloaded and is subject to change without notice. Date Created:05/11/2022

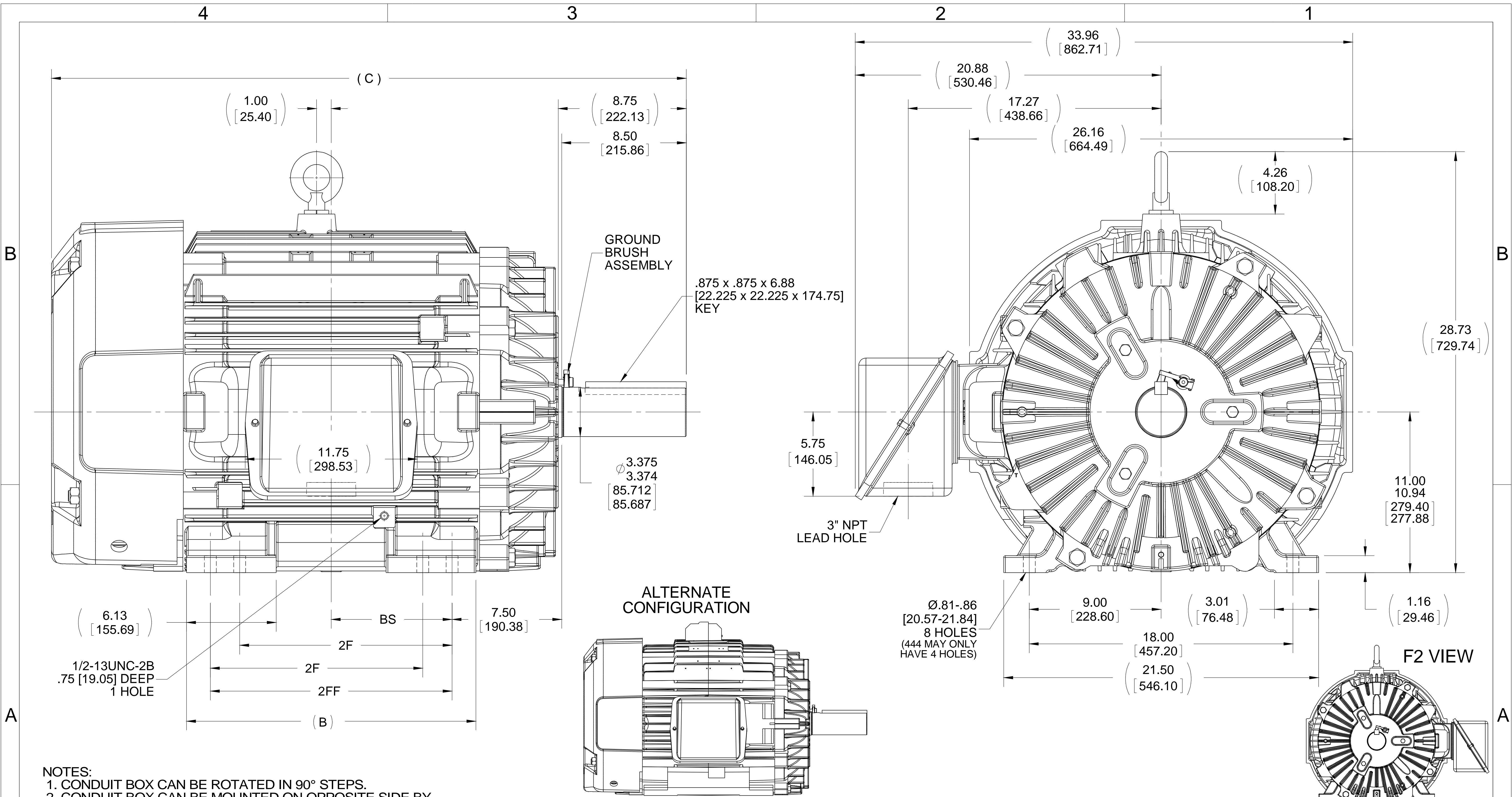

- NOTES:
 1. CONDUIT BOX CAN BE ROTATED IN 90° STEPS.
 2. CONDUIT BOX CAN BE MOUNTED ON OPPOSITE SIDE BY REMOVING BRACKETS AND TURNING FRAME 180°.
 3. NAMEPLATES TO BE READ FROM CONDUIT BOX SIDE OF MOTOR.
 4. DIMENSION IN [] DESIGNATE MILLIMETERS.

DASH	FRAME	B	C	2F	2FF	BS
1825	444T	17.75 [450.85]	41.35 [1050.29]	14.50 [368.30]	---	7.25 [184.15]
2025	444/445T	19.75 [501.65]	43.35 [1101.09]	14.50 [368.30]	16.50 [419.10]	8.25 [209.55]

DRAWING REVISION C	REVISION BY JJB	DATE 05-28-2015
ECO ECO-0078560	APPROVED BY DJK	DATE 05-28-2015
ECO DESCRIPTION UPDATED TO CURRENT STANDARDS		
<small>COPYRIGHT REGAL BELOIT AMERICA, INC. ALL RIGHTS RESERVED. PROPRIETARY AND CONFIDENTIAL INFORMATION - THIS DOCUMENT IS THE PROPERTY OF REGAL BELOIT AMERICA, INC. ("OWNER") AND CONTAINS OWNER'S PROPRIETARY INFORMATION. ANY PERSON, CORPORATION OR OTHER FIRM RECEIVING IT IS DEEMED, BY RECEIVING IT, TO AGREE THAT IT, AND/OR ANY PART OF IT, SHALL NOT BE DISCLOSED TO ANY PERSON, CORPORATION OR OTHER ENTITY, DUPLICATED, AND/OR USED, EXCEPT AS EXPRESSLY APPROVED IN WRITING IN ADVANCE BY OWNER. THIS DOCUMENT SHALL BE RETURNED TO OWNER UPON REQUEST. IT MAY BE SUBJECT TO CERTAIN RESTRICTIONS UNDER APPLICABLE EXPORT CONTROL LAWS AND REGULATIONS.</small>		

TOLERANCES UNLESS OTHERWISE SPECIFIED:

DEC.	INCH	mm	ANGLE
.X	±0.1	[±2.5]	±0.5°
.XX	±0.03	[±0.76]	
.XXX	±0.005	[±0.127]	
.XXXX	±0.0005	[±0.0127]	

REMOVE BURRS & BREAK SHARP EDGES: .003/.015 [0.076/.381] X 45°
 CORNER FILLETS: R.02 [.51]
 MACHINED SURFACES: 125 INCH 3.2 mm SHOWN IN [BRACKETS]

DRAWN BY KL	DATE 08-28-2003
APPROVED BY JES	DATE 08-28-2003
REFERENCE B-SS519554	THIRD ANGLE PROJECTION

REGAL ™ Regal Beloit America, Inc.	
DESCRIPTION OUTLINE	
444/445T FR.-TEFC-GRD BRUSH-TFN-TAPPED LEAD HOLE	
MATERIAL	PROCESS/FINISH
SIZE B	DRAWING NUMBER SS519971
	SHEET 1 OF 1

IF MOTOR HAS 9 LEADS



IF MOTOR HAS 6 LEADS



A-9806 DECAL IF CALLED FOR

IF MOTOR HAS 12 LEADS

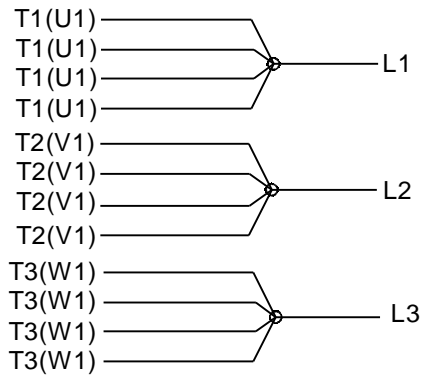

VIEW OF TERMINAL END

DRAWING REVISION L	REVISION BY AJW	DATE 05-04-2015	TOLERANCES UNLESS OTHERWISE SPECIFIED:	DRAWN BY DRS	Regal Beloit America, Inc.																					
ECO ECO-0077067	APPROVED BY EWH	DATE 05-05-2015	<table style="font-size: small; border-collapse: collapse;"> <tr> <td><u>DEC.</u></td> <td><u>INCH</u></td> <td><u>mm</u></td> <td><u>ANGLE</u></td> </tr> <tr> <td>.X</td> <td>±0.1</td> <td>[±2.5]</td> <td>±7° 30"</td> </tr> <tr> <td>.XX</td> <td>±0.02</td> <td>[±0.51]</td> <td></td> </tr> <tr> <td>.XXX</td> <td>±0.005</td> <td>[±0.127]</td> <td></td> </tr> <tr> <td>.XXXX</td> <td>±0.0005</td> <td>[±0.0127]</td> <td></td> </tr> </table>	<u>DEC.</u>			<u>INCH</u>	<u>mm</u>	<u>ANGLE</u>	.X	±0.1	[±2.5]	±7° 30"	.XX	±0.02	[±0.51]		.XXX	±0.005	[±0.127]		.XXXX	±0.0005	[±0.0127]		DATE 09-27-1996
<u>DEC.</u>	<u>INCH</u>	<u>mm</u>	<u>ANGLE</u>																							
.X	±0.1	[±2.5]	±7° 30"																							
.XX	±0.02	[±0.51]																								
.XXX	±0.005	[±0.127]																								
.XXXX	±0.0005	[±0.0127]																								
ECO DESCRIPTION UPDATED TO SOLIDWORKS <small>COPYRIGHT REGAL BELOIT AMERICA, INC. ALL RIGHTS RESERVED. PROPRIETARY AND CONFIDENTIAL INFORMATION - THIS DOCUMENT IS THE PROPERTY OF REGAL BELOIT AMERICA, INC. ("OWNER") AND CONTAINS OWNER'S PROPRIETARY INFORMATION. ANY PERSON, CORPORATION OR OTHER FIRM RECEIVING IT IS DEEMED, BY RECEIVING IT, TO AGREE THAT IT, AND/OR ANY PART OF IT, SHALL NOT BE DISCLOSED TO ANY PERSON, CORPORATION OR OTHER ENTITY, DUPLICATED, AND/OR USED, EXCEPT AS EXPRESSLY APPROVED IN WRITING IN ADVANCE BY OWNER. THIS DOCUMENT SHALL BE RETURNED TO OWNER UPON REQUEST. IT MAY BE SUBJECT TO CERTAIN RESTRICTIONS UNDER APPLICABLE EXPORT CONTROL LAWS AND REGULATIONS.</small>			APPROVED BY GK	DATE 09-30-1996	MATERIAL	PROCESS/FINISH																				
			REMOVE BURRS & BREAK SHARP EDGES: .003/.015 [.076/.381] X 45° CORNER FILLETS: R.02 [.51] MACHINED SURFACES: 200 $\sqrt{\text{INCH}}$ 5.1 $\sqrt{\text{mm}}$ mm SHOWN IN [BRACKETS]			REFERENCE	THIRD ANGLE PROJECTION	SIZE A	DRAWING NUMBER EE7300U	SHEET 1 OF 1																

CERTIFICATION DATA SHEET

Model#: 444TTFN16577 AB WINDING#: T444689 NONE 1
 CONN. DIAGRAM: A-EE7300U ASSEMBLY: F1/F2 CAPABLE
 OUTLINE: B-SS519971-1825

TYPICAL MOTOR PERFORMANCE DATA

HP	KW	SYNC. RPM	F.L. RPM	FRAME	ENCLOSURE	KVA CODE	DESIGN
100	75	1200	1188	444T	TEFC	G	B

PH	Hz	VOLTS	FL AMPS	START TYPE	DUTY	INSL	S.F	AMB°C	ELEVATION
3	60	460	124	LINE OR INVERTER	CONTINUOUS	F1	1.15	40	3300

FULL LOAD EFF: 95	3/4 LOAD EFF: 95	1/2 LOAD EFF: 94.1	GTD. EFF	ELEC. TYPE	NO LOAD AMPS
FULL LOAD PF: 80	3/4 LOAD PF: 75	1/2 LOAD PF: 64.5	94.5	SQ CAGE INV RATED	53.5

F.L. TORQUE	LOCKED ROTOR AMPS	L.R. TORQUE	B.D. TORQUE	F.L. RISE°C
442 LB-FT	725	750 LB-FT 170	1100 LB-FT 249	70

SOUND PRESSURE @ 3 FT.	SOUND POWER	ROTOR WK^2	MAX. WK^2	SAFE STALL TIME	STARTS /HOUR	APPROX. MOTOR WGT
72 dBA	82 dBA	55 LB-FT^2	1400 LB-FT^2	25 SEC.	2	1850 LBS.

*** SUPPLEMENTAL INFORMATION ***

DE BRACKET TYPE	ODE BRACKET TYPE	MOUNT TYPE	ORIENTATION	SEVERE DUTY	HAZARDOUS LOCATION	DRIP COVER	SCREENS	PAINT
STANDARD	STANDARD	RIGID	HORIZONTAL	PREMIUM SEVERE DUTY	DIVISION 2 T2B	FALSE	NONE	BLUE (EPOXY)

BEARINGS		GREASE	SHAFT TYPE	SPECIAL DE	SPECIAL ODE	SHAFT MATERIAL	FRAME MATERIAL
DE	OPE						
BALL	BALL	POLYREX EM	T	NONE	NONE	1045 HOT ROLLED (C-204)	CAST IRON
6318	6316						

THERMO-PROTECTORS				THERMISTORS	CONTROL	SPACE /n HEATERS
THERMOSTATS	PROTECTORS	WDG RTDs	BRG RTDs			
NONE	NOT	NONE	NONE	NONE	FALSE	NONE VOLTS

If Inverter equals NONE, contact factory for further information

* N O T E S *	INVERTER TORQUE: CONSTANT 2:1 INV. HP SPEED RANGE: 1.5 X BASE SPEED
	ENCODER: NONE NONE NONE NONE NONE PPR
	BRAKE: NONE NONE NONE P/N NONE NONE NONE NONE FT-LB NONE V NONE Hz

DATE: 06/21/2017 04:32:13 AM
 FORM 3531 REV.3 02/07/99
 ** Subject to change without notice.

Data Sheet

Date: 29-06-2017
 Customer: _____
 Attention: _____
 Submitted by: FAREEDA DUDEKULA



444TFN16577

Submittal

Data @ 460 V

Motor Load Data

Load	0%	25%	50%	75%	100%	115%	125%	LR
Current (Amps)	53.5	60.5	77.0	99.0	124	140	152	725
Torque (ft-lb)	0.00	110	220	331	442	509	554	750
RPM	1200	1198	1195	1192	1188	1,186	1184	0
Efficiency (%)		90.2	94.1	95.0	95.0	95.0	94.5	
P.F. (%)	4.0	43.0	64.5	75.0	80.0	81.5	82.0	28.0

Motor Speed Data

	LR	Pull-Up	BD	Rated	Idle
Speed (RPM)	0	600	1150	1188	1200
Current (Amps)	725	650	425	124	53.5
Torque (ft-lb)	750	600	1,100	442	0.00

Information Block				
HP	100.0			
Sync. RPM	1200			
Frame	444			
Enclosure	TEFC			
Construction	TFN			
Voltage	460 V			
Frequency	60 Hz			
Design	B			
LR Code letter	G			
Service Factor	1.15			
Temp Rise @ FL	70 ° C			
Duty	CONT			
Ambient	40 ° C			
Elevation	1,000 feet			
Rotor/Shaft wk ²	55.0 Lb-Ft ²			
Ref Wdg	T444689 NONE			
Sound Pressure @ 1M	72 dBA			
VFD Rating	CONSTANT 2:1			
Outline Dwg	B-SS519971-1825			
Conn. Diag	A-EE7300U			
Additional Specifications:				
0				
365THFS8036				
EQUIV CKT (OHMS / PHASE)				
R1	R2	X1	X2	Xm
0.0340	0.0220	0.2350	0.2780	4.8420

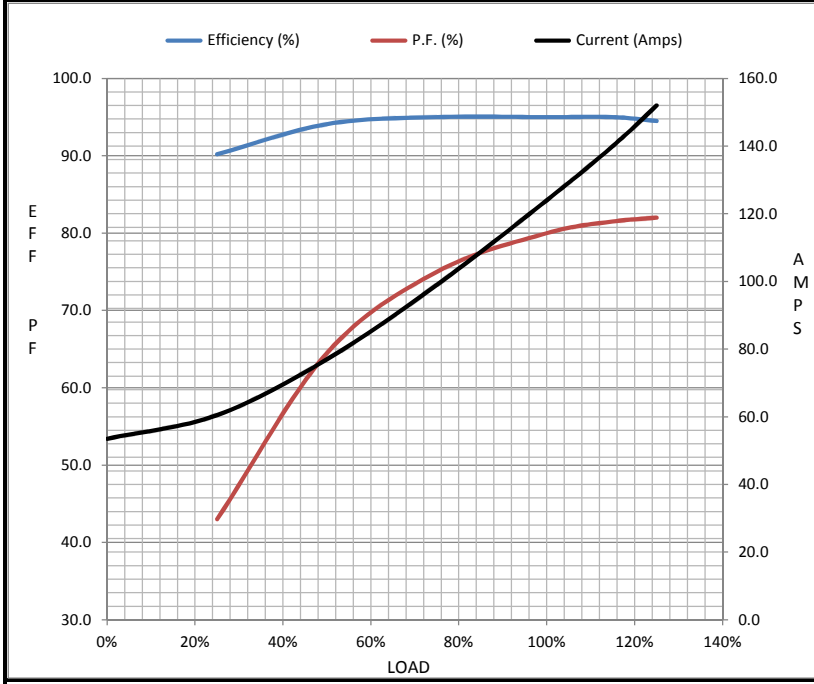

Speed - Torque Curve

