

PRODUCT INFORMATION PACKET

marathon®
Motors

Model No: 444TTFN16549

Catalog No: U880A

XRI®-SD Severe Duty Motor, 125 & 100 HP, 3 Ph, 60 & 50 Hz, 460 & 380 V, 1800 & 1500 RPM, 444T Frame,
TEFC



Regal and Marathon are trademarks of Regal Rexnord Corporation or one of its affiliated companies.

©2023 Regal Rexnord Corporation, All Rights Reserved. MC017097E

RegalRexnord



Nameplate Specifications

Phase	3	Output HP	125 & 100 Hp
Output KW	93.0 & 75.0 kW	Voltage	460 & 380 V
Speed	1785 & 1485 rpm	Service Factor	1.15 & 1.15
Frame	444T	Enclosure	Totally Enclosed Fan Cooled
Thermal Protection	No Protection	Efficiency	95.4 & 95.4 %
Ambient Temperature	40 °C	Frequency	60 & 50 Hz
Current	145 & 142 A	Power Factor	85
Duty	Continuous	Insulation Class	F
Design Code	B	KVA Code	G
Drive End Bearing Size	6318	Opp Drive End Bearing Size	6316
UL	Recognized	CSA	Y
CE	Y	IP Code	55
Number of Speeds	1		

Technical Specifications

Electrical Type	Squirrel Cage Inverter Rated	Starting Method	Line Or Inverter
Poles	4	Rotation	Reversible
Resistance Main	.04 Ohms	Mounting	Rigid Base
Motor Orientation	Horizontal	Drive End Bearing	Ball
Opp Drive End Bearing	Ball	Frame Material	Cast Iron
Shaft Type	T	Overall Length	43.35 in
Frame Length	20.25 in	Shaft Diameter	3.375 in
Shaft Extension	8.75 in	Assembly/Box Mounting	F1/F2 CAPABLE
Inverter Load	CONSTANT 2:1		
Outline Drawing	B-SS519971-2025	Connection Drawing	A-EE7300U

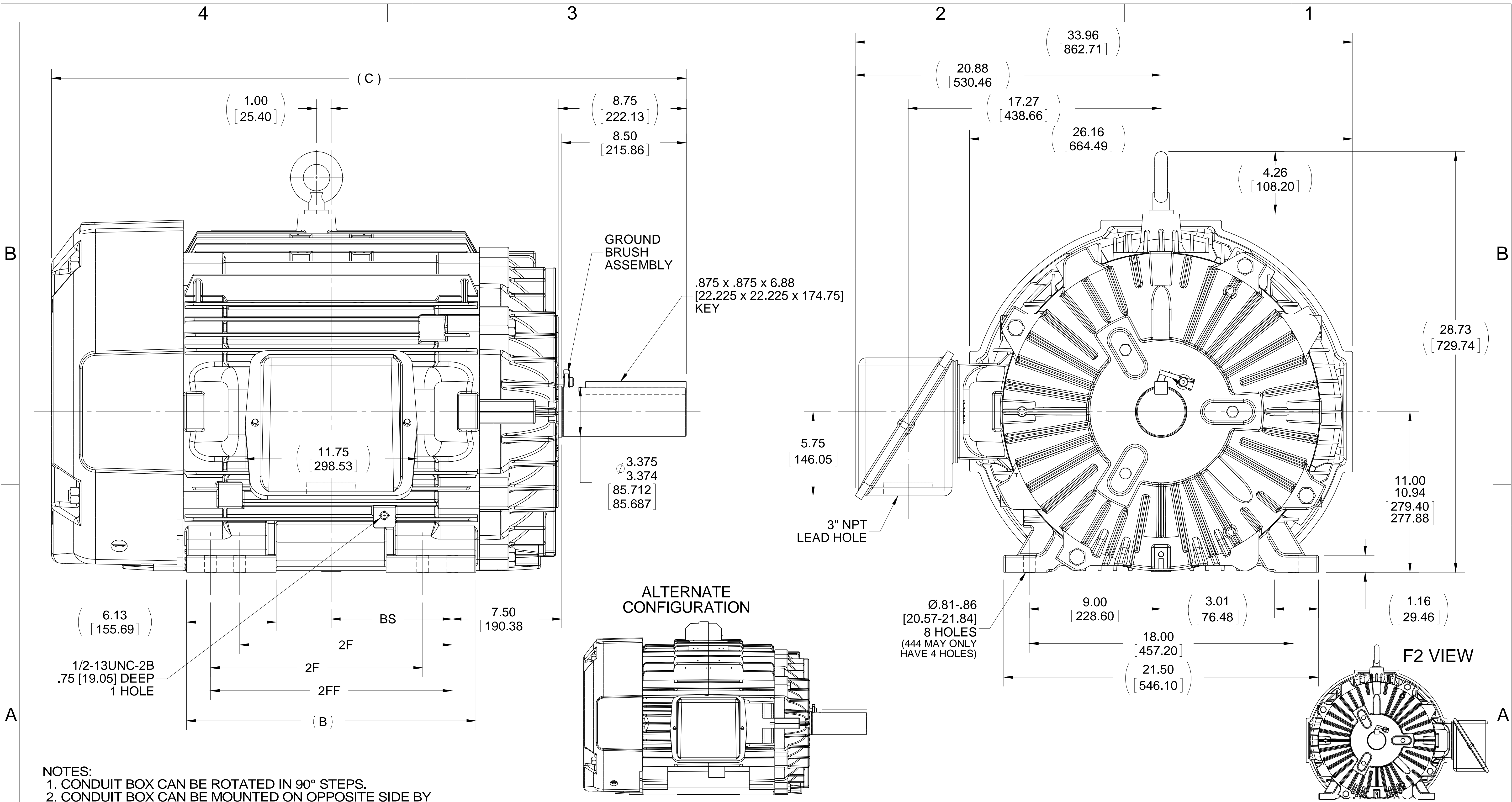

DRAWING REVISION C	REVISION BY JJB	DATE 05-28-2015
ECO ECO-0078560	APPROVED BY DJK	DATE 05-28-2015
ECO DESCRIPTION UPDATED TO CURRENT STANDARDS		
<small>COPYRIGHT REGAL BELOIT AMERICA, INC. ALL RIGHTS RESERVED. PROPRIETARY AND CONFIDENTIAL INFORMATION - THIS DOCUMENT IS THE PROPERTY OF REGAL BELOIT AMERICA, INC. ("OWNER") AND CONTAINS OWNER'S PROPRIETARY INFORMATION. ANY PERSON, CORPORATION OR OTHER FIRM RECEIVING IT IS DEEMED, BY RECEIVING IT, TO AGREE THAT IT, AND/OR ANY PART OF IT, SHALL NOT BE DISCLOSED TO ANY PERSON, CORPORATION OR OTHER ENTITY, DUPLICATED, AND/OR USED, EXCEPT AS EXPRESSLY APPROVED IN WRITING IN ADVANCE BY OWNER. THIS DOCUMENT SHALL BE RETURNED TO OWNER UPON REQUEST. IT MAY BE SUBJECT TO CERTAIN RESTRICTIONS UNDER APPLICABLE EXPORT CONTROL LAWS AND REGULATIONS.</small>		

TOLERANCES UNLESS OTHERWISE SPECIFIED:

DEC.	INCH	mm	ANGLE
.X	±0.1	[±2.5]	±0.5°
.XX	±0.03	[±0.76]	
.XXX	±0.005	[±0.127]	
.XXXX	±0.0005	[±0.0127]	

REMOVE BURRS & BREAK SHARP EDGES: .003/.015 [0.076/.381] X 45° CORNER FILLETS: R.02 [.51] MACHINED SURFACES: 125 INCH 3.2 mm SHOWN IN [BRACKETS]

DRAWN BY KL	DATE 08-28-2003
APPROVED BY JES	DATE 08-28-2003
REFERENCE B-SS519554	THIRD ANGLE PROJECTION

REGAL ™ Regal Beloit America, Inc.	
DESCRIPTION OUTLINE	
444/445T FR.-TEFC-GRD BRUSH-TFN-TAPPED LEAD HOLE	
MATERIAL	PROCESS/FINISH
SIZE B	DRAWING NUMBER SS519971
	SHEET 1 OF 1

IF MOTOR HAS 9 LEADS

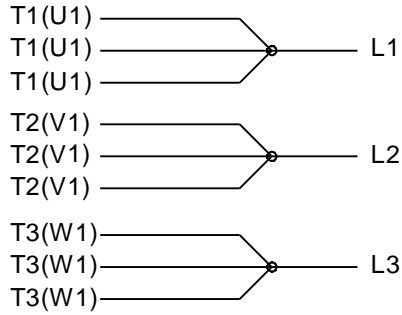

IF MOTOR HAS 6 LEADS

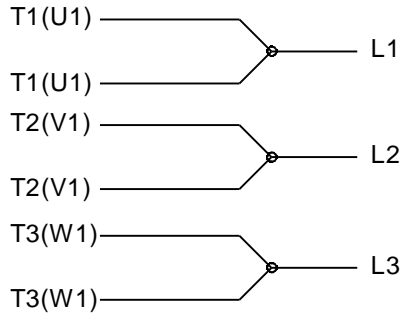

A-9806 DECAL IF CALLED FOR

IF MOTOR HAS 12 LEADS

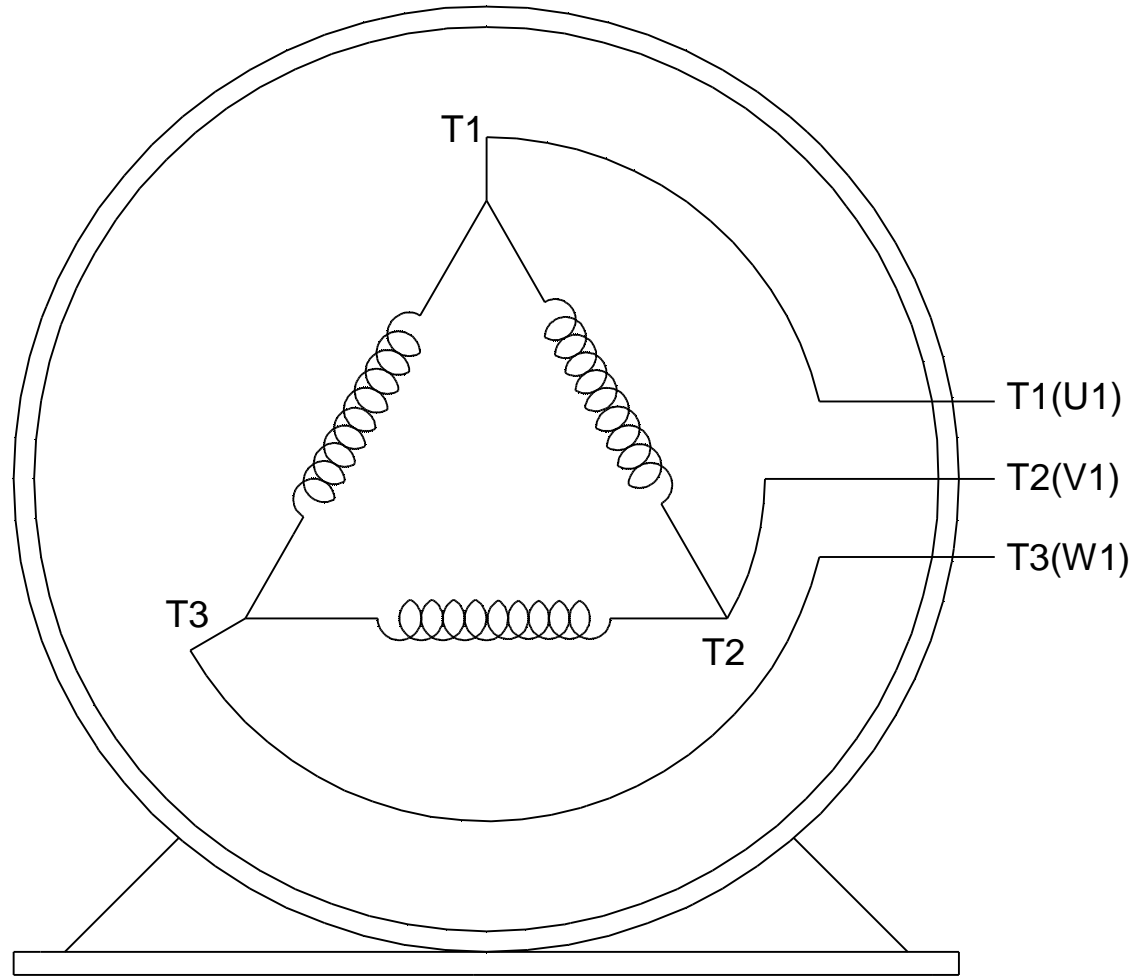
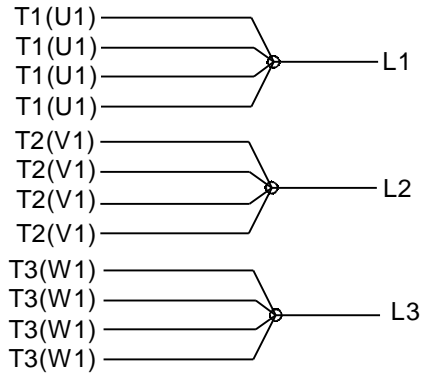

VIEW OF TERMINAL END

DRAWING REVISION L	REVISION BY AJW	DATE 05-04-2015	TOLERANCES UNLESS OTHERWISE SPECIFIED:	DRAWN BY DRS	Regal Beloit America, Inc.																					
ECO ECO-0077067	APPROVED BY EWH	DATE 05-05-2015	<table style="font-size: small; border-collapse: collapse;"> <tr> <td><u>DEC.</u></td> <td><u>INCH</u></td> <td><u>mm</u></td> <td><u>ANGLE</u></td> </tr> <tr> <td>.X</td> <td>±0.1</td> <td>[±2.5]</td> <td>±7' 30"</td> </tr> <tr> <td>.XX</td> <td>±0.02</td> <td>[±0.51]</td> <td></td> </tr> <tr> <td>.XXX</td> <td>±0.005</td> <td>[±0.127]</td> <td></td> </tr> <tr> <td>.XXXX</td> <td>±0.0005</td> <td>[±0.0127]</td> <td></td> </tr> </table>	<u>DEC.</u>			<u>INCH</u>	<u>mm</u>	<u>ANGLE</u>	.X	±0.1	[±2.5]	±7' 30"	.XX	±0.02	[±0.51]		.XXX	±0.005	[±0.127]		.XXXX	±0.0005	[±0.0127]		DATE 09-27-1996
<u>DEC.</u>	<u>INCH</u>	<u>mm</u>	<u>ANGLE</u>																							
.X	±0.1	[±2.5]	±7' 30"																							
.XX	±0.02	[±0.51]																								
.XXX	±0.005	[±0.127]																								
.XXXX	±0.0005	[±0.0127]																								
ECO DESCRIPTION UPDATED TO SOLIDWORKS			APPROVED BY GK	DATE 09-30-1996	MATERIAL	PROCESS/FINISH																				
COPYRIGHT REGAL BELOIT AMERICA, INC. ALL RIGHTS RESERVED. PROPRIETARY AND CONFIDENTIAL INFORMATION - THIS DOCUMENT IS THE PROPERTY OF REGAL BELOIT AMERICA, INC. ("OWNER") AND CONTAINS OWNER'S PROPRIETARY INFORMATION. ANY PERSON, CORPORATION OR OTHER FIRM RECEIVING IT IS DEEMED, BY RECEIVING IT, TO AGREE THAT IT, AND/OR ANY PART OF IT, SHALL NOT BE DISCLOSED TO ANY PERSON, CORPORATION OR OTHER ENTITY, DUPLICATED, AND/OR USED, EXCEPT AS EXPRESSLY APPROVED IN WRITING IN ADVANCE BY OWNER. THIS DOCUMENT SHALL BE RETURNED TO OWNER UPON REQUEST. IT MAY BE SUBJECT TO CERTAIN RESTRICTIONS UNDER APPLICABLE EXPORT CONTROL LAWS AND REGULATIONS.			REMOVE BURRS & BREAK SHARP EDGES: .003/.015 [.076/.381] X 45° CORNER FILLETS: R.02 [.51] MACHINED SURFACES: 200 $\sqrt{\text{INCH}}$ 5.1 $\sqrt{\text{mm}}$ mm SHOWN IN [BRACKETS]	REFERENCE	SIZE A	DRAWING NUMBER EE7300U	SHEET 1 OF 1																			
				THIRD ANGLE PROJECTION																						

CERTIFICATION DATA SHEET

Model#: 444TTFN16549 AA **WINDING#:** T4444119 NONE 1
CONN. DIAGRAM: A-EE7300U **ASSEMBLY:** F1/F2 CAPABLE
OUTLINE: B-SS519971-2025

TYPICAL MOTOR PERFORMANCE DATA

HP	KW	SYNC. RPM	F.L. RPM	FRAME	ENCLOSURE	KVA CODE	DESIGN
125&100	93&75	1800	1785&1485	444T	TEFC	G	B

PH	Hz	VOLTS	FL AMPS	START TYPE	DUTY	INSL	S.F	AMB°C	ELEVATION
3	60/50	460#380	145&142	LINE OR INVERTER	CONTINUOU S	F1	1.15/1.15	40	3300

FULL LOAD EFF: 95.4&95.4	3/4 LOAD EFF: 95.4	1/2 LOAD EFF: 95	GTD. EFF	ELEC. TYPE	NO LOAD AMPS
FULL LOAD PF: 85&85.5	3/4 LOAD PF: 81.5	1/2 LOAD PF: 73	95	SQ CAGE INV RATED	52

F.L. TORQUE	LOCKED ROTOR AMPS	L.R. TORQUE	B.D. TORQUE	F.L. RISE°C
368 LB-FT	907	525 LB-FT 142	1050 LB-FT 285	70

SOUND PRESSURE @ 3 FT.	SOUND POWER	ROTOR WK^2	MAX. WK^2	SAFE STALL TIME	STARTS /HOUR	APPROX. MOTOR WGT
75 dBA	85 dBA	41.5 LB-FT^2	- LB-FT^2	25 SEC.	-	1800 LBS.

*** SUPPLEMENTAL INFORMATION ***

DE BRACKET TYPE	ODE BRACKET TYPE	MOUNT TYPE	ORIENTATION	SEVERE DUTY	HAZARDOUS LOCATION	DRIP COVER	SCREENS	PAINT
STANDARD	STANDARD	RIGID	HORIZONTAL	PREMIUM SEVERE DUTY	NONE	FALSE	NONE	BLUE (EPOXY)

BEARINGS		GREASE	SHAFT TYPE	SPECIAL DE	SPECIAL ODE	SHAFT MATERIAL	FRAME MATERIAL
DE	OPE						
BALL	BALL	POLYREX EM	T	NONE	NONE	1045 HOT ROLLED (C-204)	CAST IRON
6318	6316						

THERMO-PROTECTORS				THERMISTORS	CONTROL	SPACE /n HEATERS
THERMOSTATS	PROTECTORS	WDG RTDs	BRG RTDs			
NONE	NOT	NONE	NONE	NONE	FALSE	NONE VOLTS

If Inverter equals NONE, contact factory for further information

*
N
O
T
E
S
*

INVERTER TORQUE: CONSTANT 2:1 INV. HP SPEED RANGE: NONE
ENCODER: NONE NONE NONE NONE NONE PPR
BRAKE: NONE NONE NONE P/N NONE NONE NONE NONE FT-LB NONE V NONE Hz

DATE: 06/21/2017 04:31:11 AM
FORM 3531 REV.3 02/07/99
** Subject to change without notice.

Data Sheet

Date: 15-06-2017
 Customer: _____
 Attention: _____
 Submitted by: FAREEDA DUDEKULA



444TFN16549

Submittal

Data @ 460 V

Motor Load Data

Load	0%	25%	50%	75%	100%	115%	125%	LR
Current (Amps)	52.0	62.0	85.0	114	145	165	180	907
Torque (ft-lb)	0.00	91.5	183	275	368	425	462	525
RPM	1800	1795	1792	1790	1785	1,782	1780	0
Efficiency (%)		91.7	95.0	95.4	95.4	95.4	95.0	
P.F. (%)	4.5	52.0	73.0	81.5	85.0	85.5	86.0	26.0

Motor Speed Data

	LR	Pull-Up	BD	Rated	Idle
Speed (RPM)	0	900	1725	1785	1800
Current (Amps)	907	800	600	145	52.0
Torque (ft-lb)	525	425	1,050	368	0.00

Information Block				
HP	125.0			
Sync. RPM	1800			
Frame	444			
Enclosure	TEFC			
Construction	TFN			
Voltage	460#380 V			
Frequency	60 Hz			
Design	A			
LR Code letter	G			
Service Factor	1.15			
Temp Rise @ FL	70 ° C			
Duty	CONT			
Ambient	40 ° C			
Elevation	1,000 feet			
Rotor/Shaft wk ²	41.5 Lb-Ft ²			
Ref Wdg	T4444119 NONE			
Sound Pressure @ 1M	75 dBA			
VFD Rating	CONSTANT 2:1			
Outline Dwg	B-SS519971-2025			
Conn. Diag	A-EE7300U			
Additional Specifications:				
0				
365THFS8036				
EQUIV CKT (OHMS / PHASE)				
R1	R2	X1	X2	Xm
0.0300	0.0150	0.2170	0.1850	5.0440

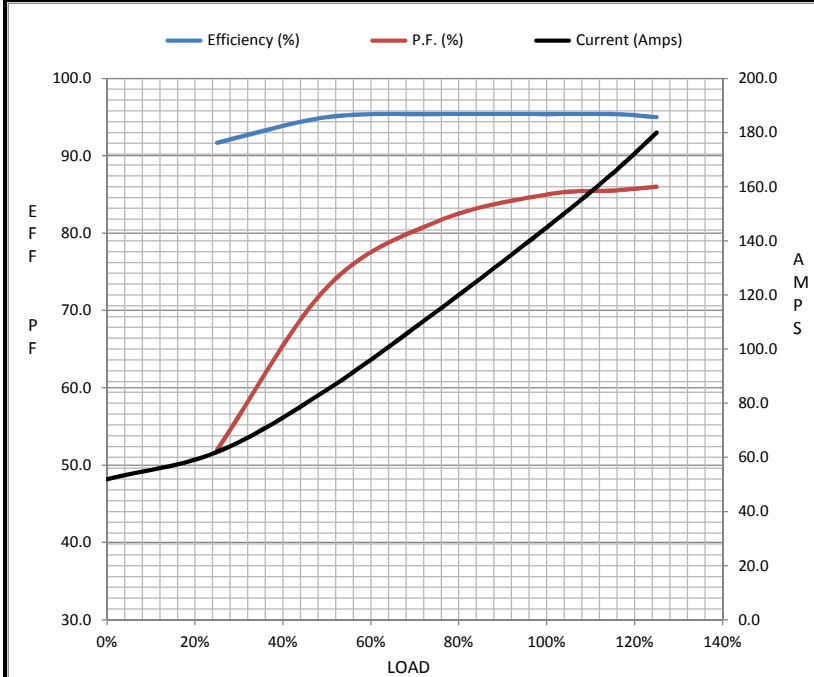

Speed - Torque Curve

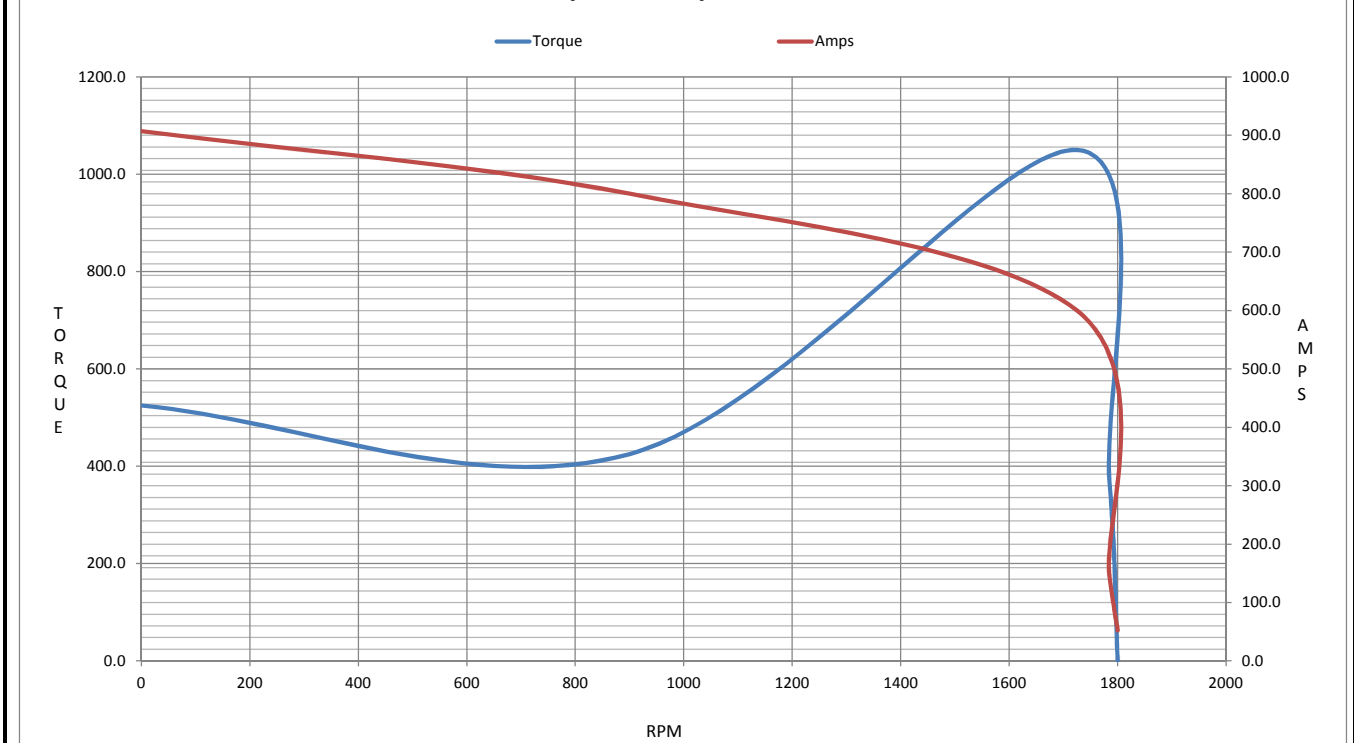

EC Declaration of Conformity

The undersigned representing
the manufacturer:

Regal Beloit America
100 East Randolph St.
Wausau, WI 54401

and the authorized representative
established within the Community:

Marathon Electric UK
6F Thistleton Road Ind. Estate
Market Overton
Oakham, Rutland LE15 7PP UK

are committed to providing customers with products that comply with applicable regulations and international protocols to which they are subject, including the requirements of the European Parliament Directive on the Harmonization of the laws relating to electrical equipment designed for use within certain voltage limits (2014/35/EU).

Regal Beloit America declares that the following product(s), to which this declaration relates, are in conformity with the relevant sections of the EC standards listed below.

This statement supersedes any statements previously issued pertaining to the product(s) listed below and is subject to change without notice.

Model No : 444TTFN16549

(Model No. may contain prefix and/or suffix characters)

Catalog No : U880A

Rework No : N/A

Directives :

Low Voltage Directive 2014/35/EU

Harmonized Standards Used :

EN 60034-1: 2010 (IEC 60034-1: 2010)

EN 60034-5: 2001/A1:2007 (IEC 60034-5: 2000/A1:2006)

Authorized Representative:



Michael A. Logsdon
Vice President, Technology

Authorized Representative in the Community:



Julian Clark
Marketing Engineer

Created on 09/01/2022

CE 22