

PRODUCT INFORMATION PACKET

Model No: 444TSTGS1001

Catalog No: U977

Other Purpose Motor, 125 & 100 HP, 3 Ph, 60 & 50 Hz, 460 & 380 V, 3600 & 3000 RPM, 444TS Frame,
EPFC



Regal and Marathon are trademarks of Regal Rexnord Corporation or one of its affiliated companies.

©2023 Regal Rexnord Corporation, All Rights Reserved. MC017097E

Nameplate Specifications

Phase	3	Output HP	125 & 100 Hp
Output KW	93.0 & 75.0 kW	Voltage	460 & 380 V
Speed	3565 & 2960 rpm	Service Factor	1.15 & 1.15
Frame	444TS	Enclosure	Explosion Proof Fan cooled
Thermal Protection	No Protection	Efficiency	94.5 & 94.1 %
Ambient Temperature	40 °C	Frequency	60 & 50 Hz
Current	137 & 136 A	Power Factor	90.5
Duty	Continuous	Insulation Class	F
Design Code	B	KVA Code	G
Drive End Bearing Size	6313	Opp Drive End Bearing Size	6313
UL	Listed	CSA	Y
CE	N	IP Code	54
Number of Speeds	1		

Technical Specifications

Electrical Type	Squirrel Cage Induction Run	Starting Method	Across The Line
Poles	2	Rotation	Reversible
Resistance Main	.032 Ohms	Mounting	Rigid Base
Motor Orientation	Horizontal	Drive End Bearing	Ball
Opp Drive End Bearing	Ball	Frame Material	Cast Iron
Shaft Type	TS	Overall Length	37.50 in
Frame Length	18.50 in	Shaft Diameter	2.375 in
Shaft Extension	4.75 in	Assembly/Box Mounting	F1 ONLY
Connection Drawing	A-EE7300U	Outline Drawing	B-SS519043-1850

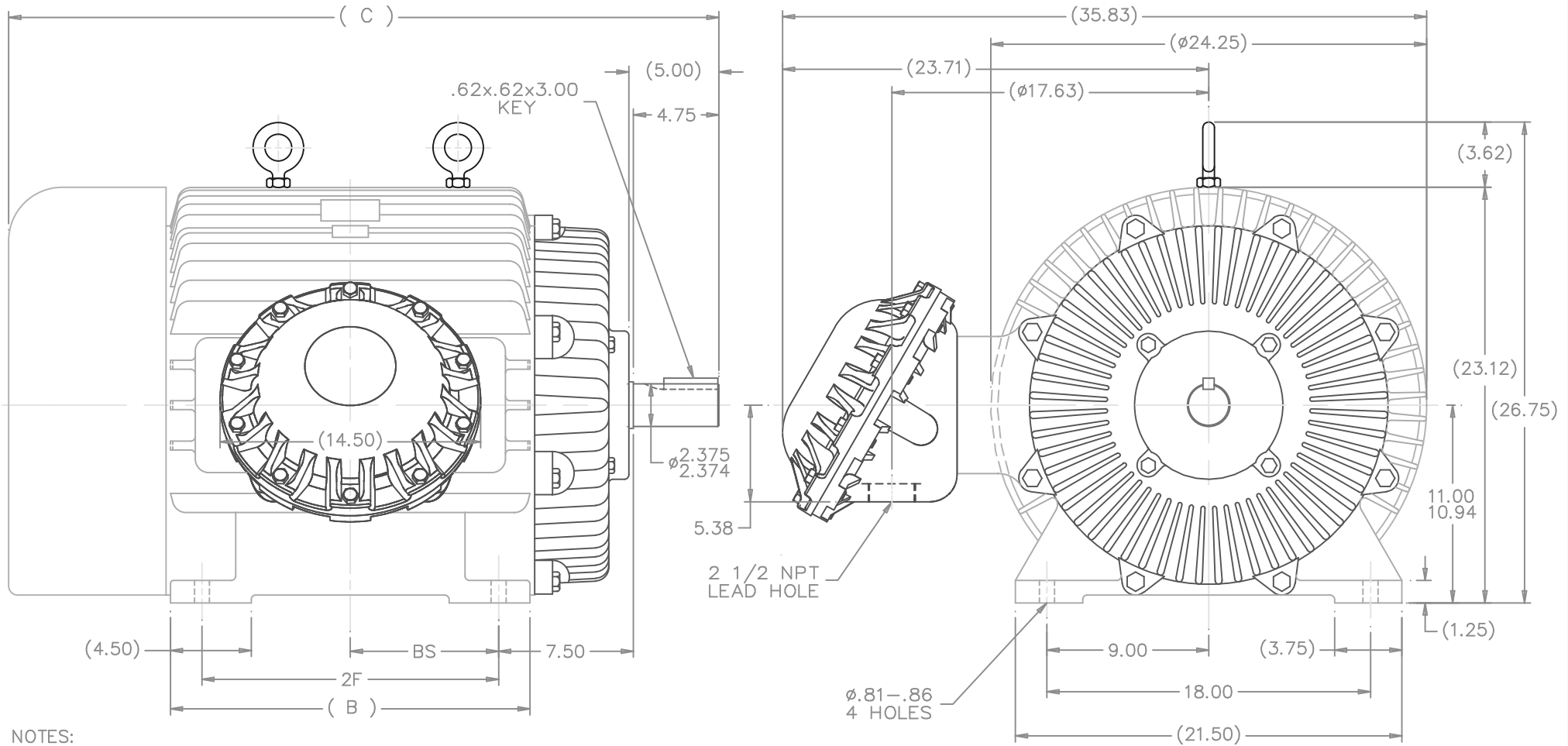

NOTES:

1. BOX CAN BE ROTATED IN 90° STEPS
2. BOX CAN BE MOUNTED ON OPPOSITE SIDE BY REMOVING BRACKETS AND TURNING FRAME 180°
3. NAMEPLATES TO BE READ FROM CONDUIT BOX SIDE OF MOTOR

DASH	FRAME	B	C	2F	BS
1850	444TS	18.00	37.50	14.50	7.25
2050	445TS	20.00	39.50	16.50	8.25

			TOLERANCES UNLESS SPECIFIED		MARATHON ELECTRIC		DRAWN MSG 06-14-2002	
			DEC.	INCHES			CHK	JHL 06-21-2002
			.X	±.1			APPD	JES 06-21-2002
			.XX	±.03	TITLE OUTLINE		SCALE	3=16
			.XXX	±.005	440TS FR. - EXP. PR. - STD.		REF	(B-SS504768)
1	NEW DRAWING	CN 34629	MSG 06-21-2002	JHL .XXXX ±.0005	MAT'L		FMF	
NO. REVISION			BY & DATE	CHK ANG ±7'30"	FINISH		PREV	
THIS DRAWING IN DESIGN AND DETAIL IS OUR PROPERTY AND MUST NOT BE USED EXCEPT IN CONNECTION WITH OUR WORK ALL RIGHTS OF DESIGN AND INVENTION ARE RESERVED THIS IS AN ELECTRONICALLY GENERATED DOCUMENT - DO NOT SCALE THIS PRINT					RFP	CAD FILE SS519043	SIZE	DRAWING NO. PAGE OF REV.
					DIST WA		B	SS519043 1

IF MOTOR HAS 9 LEADS



IF MOTOR HAS 6 LEADS



A-9806 DECAL IF CALLED FOR

IF MOTOR HAS 12 LEADS



VIEW OF TERMINAL END

DRAWING REVISION L	REVISION BY AJW	DATE 05-04-2015	TOLERANCES UNLESS OTHERWISE SPECIFIED:	DRAWN BY DRS	Regal Beloit America, Inc.																					
ECO ECO-0077067	APPROVED BY EWH	DATE 05-05-2015	<table style="font-size: small; border-collapse: collapse;"> <tr> <td><u>DEC.</u></td> <td><u>INCH</u></td> <td><u>mm</u></td> <td><u>ANGLE</u></td> </tr> <tr> <td>.X</td> <td>±0.1</td> <td>[±2.5]</td> <td>±7' 30"</td> </tr> <tr> <td>.XX</td> <td>±0.02</td> <td>[±0.51]</td> <td></td> </tr> <tr> <td>.XXX</td> <td>±0.005</td> <td>[±0.127]</td> <td></td> </tr> <tr> <td>.XXXX</td> <td>±0.0005</td> <td>[±0.0127]</td> <td></td> </tr> </table>	<u>DEC.</u>			<u>INCH</u>	<u>mm</u>	<u>ANGLE</u>	.X	±0.1	[±2.5]	±7' 30"	.XX	±0.02	[±0.51]		.XXX	±0.005	[±0.127]		.XXXX	±0.0005	[±0.0127]		DATE 09-27-1996
<u>DEC.</u>	<u>INCH</u>	<u>mm</u>	<u>ANGLE</u>																							
.X	±0.1	[±2.5]	±7' 30"																							
.XX	±0.02	[±0.51]																								
.XXX	±0.005	[±0.127]																								
.XXXX	±0.0005	[±0.0127]																								
ECO DESCRIPTION UPDATED TO SOLIDWORKS <small>COPYRIGHT REGAL BELOIT AMERICA, INC. ALL RIGHTS RESERVED. PROPRIETARY AND CONFIDENTIAL INFORMATION - THIS DOCUMENT IS THE PROPERTY OF REGAL BELOIT AMERICA, INC. ("OWNER") AND CONTAINS OWNER'S PROPRIETARY INFORMATION. ANY PERSON, CORPORATION OR OTHER FIRM RECEIVING IT IS DEEMED, BY RECEIVING IT, TO AGREE THAT IT, AND/OR ANY PART OF IT, SHALL NOT BE DISCLOSED TO ANY PERSON, CORPORATION OR OTHER ENTITY, DUPLICATED, AND/OR USED, EXCEPT AS EXPRESSLY APPROVED IN WRITING IN ADVANCE BY OWNER. THIS DOCUMENT SHALL BE RETURNED TO OWNER UPON REQUEST. IT MAY BE SUBJECT TO CERTAIN RESTRICTIONS UNDER APPLICABLE EXPORT CONTROL LAWS AND REGULATIONS.</small>			APPROVED BY GK	MATERIAL _____ PROCESS/FINISH _____																						
			DATE 09-30-1996			REFERENCE	SIZE A	DRAWING NUMBER EE7300U	SHEET 1 OF 1																	
			REMOVE BURRS & BREAK SHARP EDGES: .003/.015 [.076/.381] X 45° CORNER FILLETS: R.02 [.51] MACHINED SURFACES: 200 $\sqrt{\text{INCH}}$ 5.1 $\sqrt{\text{mm}}$ mm SHOWN IN [BRACKETS]	THIRD ANGLE PROJECTION																						