

PRODUCT INFORMATION PACKET

Model No: 405TTGS4040

Catalog No: U035

Explosion Proof Motor, 100 HP, 3 Ph, 60 Hz, 575 V, 1800 RPM, 405T Frame, EPFC

Regal and are trademarks of Regal Rexnord Corporation or one of its affiliated companies.
©2022 Regal Rexnord Corporation, All Rights Reserved. MC017097E



Nameplate Specifications

Output HP	100 Hp	Output KW	75.0 kW
Frequency	60 Hz	Voltage	575 V
Current	91.0 A	Speed	1780 rpm
Service Factor	1.15	Phase	3
Efficiency	94.5 %	Power Factor	87
Duty	Continuous	Insulation Class	F
Design Code	B	KVA Code	G
Frame	405T	Enclosure	Explosion Proof Fan cooled
Thermal Protection	Thermostat	Ambient Temperature	40 °C
Drive End Bearing Size	6316	Opp Drive End Bearing Size	6313
UL	UL Listed And CSA Certified	CSA	Y
CE	N	IP Code	54
Hazardous Location	EXP PROOF CL I GR C&D CL II GR F&G T3B	Number of Speeds	1

Technical Specifications

Electrical Type	Squirrel Cage Inverter Rated	Starting Method	Line Or Inverter
Poles	4	Rotation	Reversible
Resistance Main	.055 Ohms	Mounting	Rigid Base
Motor Orientation	Horizontal	Drive End Bearing	Ball
Opp Drive End Bearing	Ball	Frame Material	Cast Iron
Shaft Type	T	Overall Length	37.75 in
Frame Length	16.75 in	Shaft Diameter	2.875 in
Shaft Extension	7.5 in	Assembly/Box Mounting	F1 ONLY
Inverter Load	CONSTANT 2:1		
Connection Drawing	A-EE7300S	Outline Drawing	B-SS518936-1675

This is an uncontrolled document once printed or downloaded and is subject to change without notice. Date Created:09/06/2022

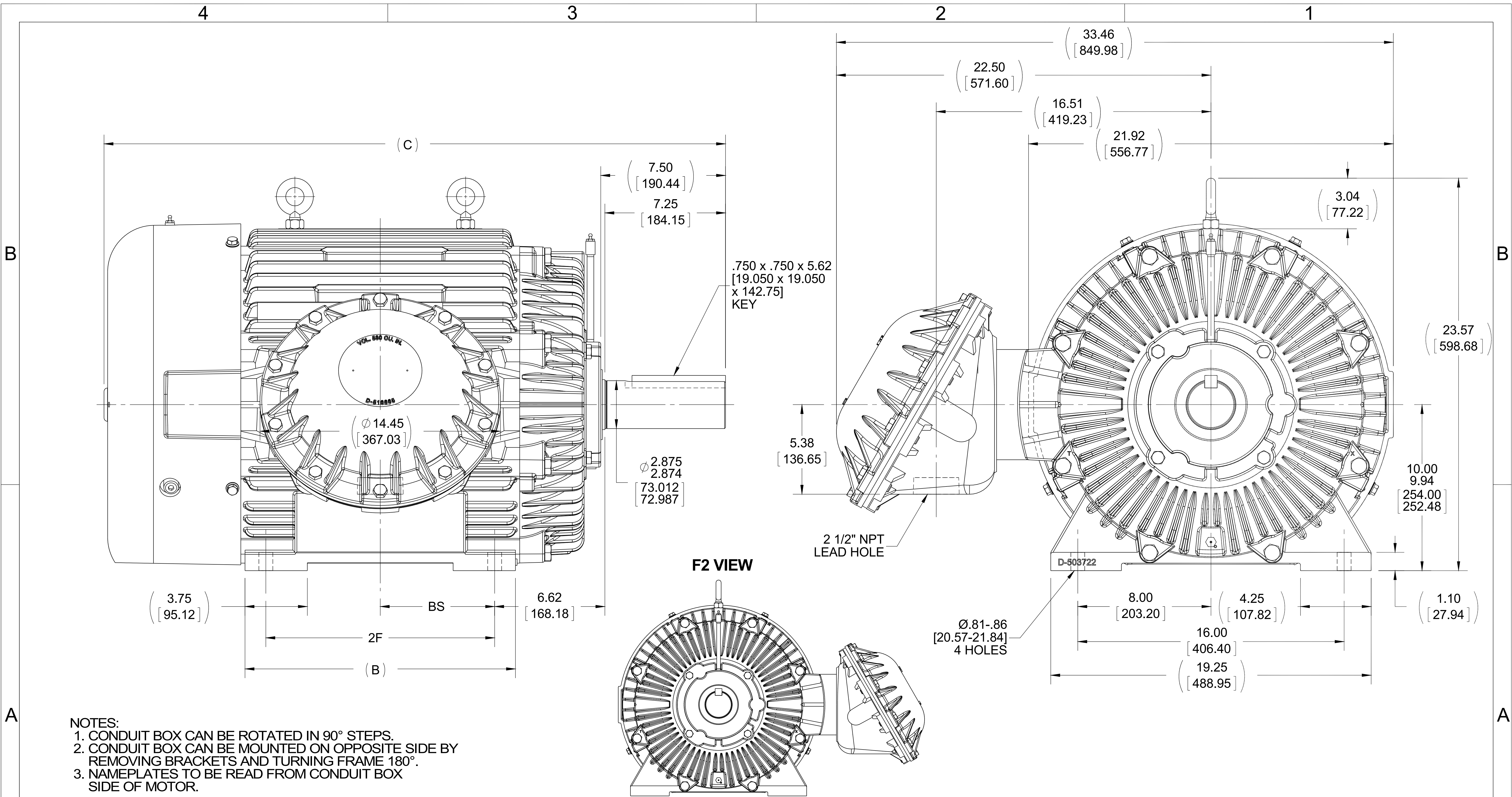

- NOTES:
 1. CONDUIT BOX CAN BE ROTATED IN 90° STEPS.
 2. CONDUIT BOX CAN BE MOUNTED ON OPPOSITE SIDE BY REMOVING BRACKETS AND TURNING FRAME 180°.
 3. NAMEPLATES TO BE READ FROM CONDUIT BOX SIDE OF MOTOR.

DASH	FRAME	B	C	2F	BS
1525	404T	14.75 [374.65]	35.85 [910.59]	12.25 [311.15]	6.12 [155.45]
1675	405T	16.25 [412.75]	37.35 [948.69]	13.75 [349.25]	6.88 [174.75]

DRAWING REVISION E
 REVISION BY JJB
 DATE 02-19-2016
 APPROVED BY JHA
 DATE 02-19-2016
 ECO ECO-0091102
 ECO DESCRIPTION
 UPDATED TO CURRENT STANDARDS
 COPYRIGHT REGAL BELOIT AMERICA, INC. ALL RIGHTS RESERVED. PROPRIETARY AND CONFIDENTIAL INFORMATION - THIS DOCUMENT IS THE PROPERTY OF REGAL BELOIT AMERICA, INC. ("OWNER") AND CONTAINS OWNER'S PROPRIETARY INFORMATION. ANY PERSON, CORPORATION OR OTHER FIRM RECEIVING IT IS DEEMED, BY RECEIVING IT, TO AGREE THAT IT, AND/OR ANY PART OF IT, SHALL NOT BE DISCLOSED TO ANY PERSON, CORPORATION OR OTHER ENTITY, DUPLICATED, AND/OR USED, EXCEPT AS EXPRESSLY APPROVED IN WRITING IN ADVANCE BY OWNER. THIS DOCUMENT SHALL BE RETURNED TO OWNER UPON REQUEST. IT MAY BE SUBJECT TO CERTAIN RESTRICTIONS UNDER APPLICABLE EXPORT CONTROL LAWS AND REGULATIONS.

TOLERANCES UNLESS OTHERWISE SPECIFIED:
 DEC. X ±0.1 [±2.5] ANGLE ±7° 30"
 .XX ±0.03 [±0.76]
 .XXX ±0.005 [±0.127]
 .XXXX ±0.0005 [±0.0127]
 REMOVE BURRS & BREAK SHARP EDGES: .003/.015 [0.076/.381] X 45°
 CORNER FILLETS: R.02 [0.51]
 MACHINED SURFACES: 200 INCH mm 5.1
 mm SHOWN IN [BRACKETS]

DRAWN BY MSG
 DATE 03-06-2002
 APPROVED BY JES
 DATE 03-20-2002
 REFERENCE
 THIRD ANGLE PROJECTION

REGAL™ Regal Beloit America, Inc.
 DESCRIPTION
OUTLINE
 400T FR. - TEFC - EXP. PR. - (STD.)
 MATERIAL PROCESS/FINISH
 SIZE B DRAWING NUMBER **SS518936** SHEET 1 OF 1

EE7300S

THREE PHASE – SINGLE VOLTAGE MOTOR

TO REVERSE ROTATION:
INTERCHANGE ANY TWO LINE
LEAD CONNECTIONS

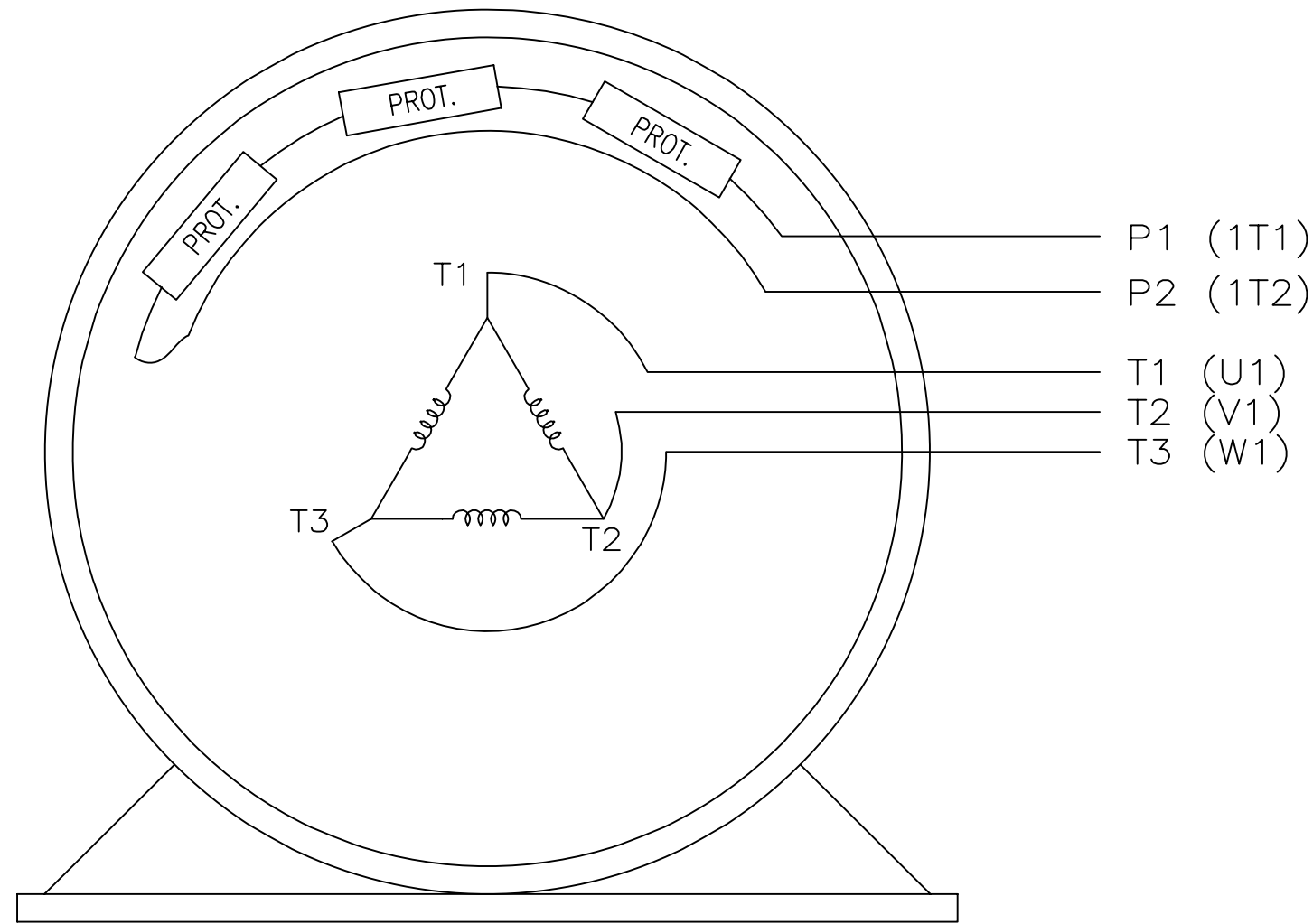

VIEW OF TERMINAL END

IF MOTOR HAS MULTIPLE
T'S PER LEAD CONNECT
TOGETHER LIKE T'S

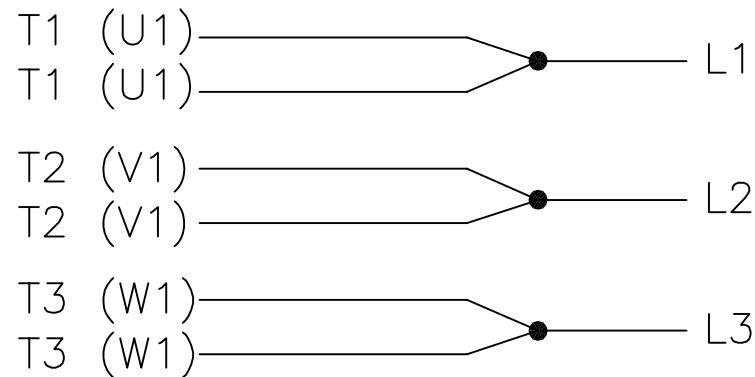

A-9806 DECAL

NO.	REVISION	BY & DATE	CHK	TOLERANCES UNLESS SPECIFIED			DRAWN	PAGE	OF	REV.		
				DEC.	INCHES							
F	UPDATED TITLE BLOCK	HV 02-27-2014	EWB	.X	±	-	KL	12-15-1999				
3	REMOVED "N.C." FROM PROT.'S MU61770	JJB 08-02-2010		.XX	±	-	CHK	DJK 12-15-1999				
2	ADDED IEC MARKINGS MU61770	KL 09-16-2004	EAB	.XXX	±	-	APPD	DJK 12-15-1999				
1	NEW DRAWING	KL 12-16-1999		.XXXX	±	-			SCALE	1=1		
									REF			
									FMF			
									PREV			
THIS DRAWING IN DESIGN AND DETAIL IS OUR PROPERTY AND MUST NOT BE USED EXCEPT IN CONNECTION WITH OUR WORK ALL RIGHTS OF DESIGN AND INVENTION ARE RESERVED THIS IS AN ELECTRONICALLY GENERATED DOCUMENT – DO NOT SCALE THIS PRINT				RFP	CAD FILE ee7300s			SIZE	DRAWING NO.	PAGE	OF	REV.
				DIST	WA-LB-SB			A	EE7300S			F

