

# PRODUCT INFORMATION PACKET

**marathon®**  
Motors

Model No: 405TSTD6007

Catalog No: GT0051A

Globetrotter® General Purpose Motor, 150 & 125 HP, 3 Ph, 60 & 50 Hz, 460 & 380 V, 3600 & 3000 RPM,  
405TS Frame, DP



Regal and Marathon are trademarks of Regal Rexnord Corporation or one of its affiliated companies.  
©2024 Regal Rexnord Corporation, All Rights Reserved. MC017097E

**RegalRexnord**

### Nameplate Specifications

Phase	3	Output HP	150 & 125 Hp
Output KW	112.0 & 93.0 kW	Voltage	460 & 380 V
Speed	3575 & 2972 rpm	Service Factor	1.15 & 1.15
Frame	405TS	Enclosure	Drip Proof
Thermal Protection	No Protection	Efficiency	94.1 & 94.1 %
Ambient Temperature	40 °C	Frequency	60 & 50 Hz
Current	165 & 167 A	Power Factor	90
Duty	Continuous	Insulation Class	F
Design Code	B	KVA Code	F
Drive End Bearing Size	6313	Opp Drive End Bearing Size	6313
UL	Recognized	CSA	Y
CE	Y	IP Code	22
Number of Speeds	1		

### Technical Specifications

Electrical Type	Squirrel Cage Inverter Rated	Starting Method	Part Wdg Start Or Inverter
Poles	2	Rotation	Reversible
Resistance Main	.045 Ohms	Mounting	Rigid Base
Motor Orientation	Horizontal	Drive End Bearing	Ball
Opp Drive End Bearing	Ball	Frame Material	Cast Iron
Shaft Type	TS	Overall Length	35.44 in
Shaft Diameter	4.250 in	Shaft Extension	2.125 in
Assembly/Box Mounting	F1/F2 CAPABLE	Inverter Load	VARIABLE 10:1
Outline Drawing	SS620752-200	Connection Drawing	EE7341C

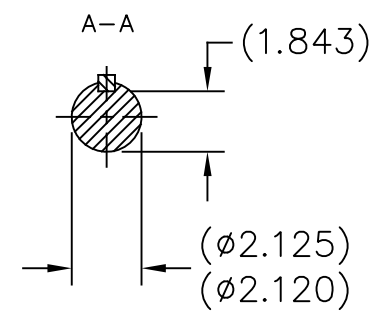
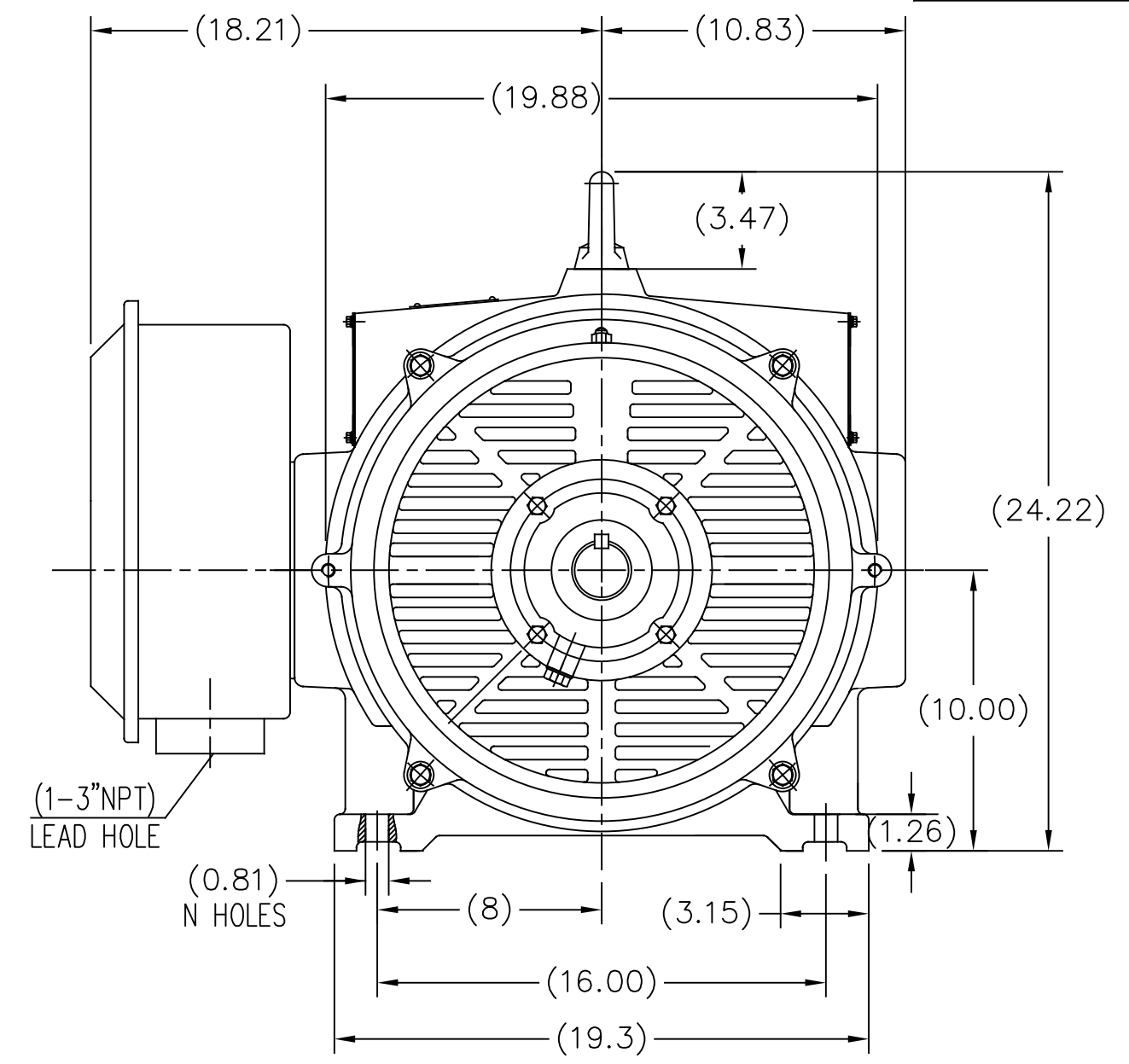
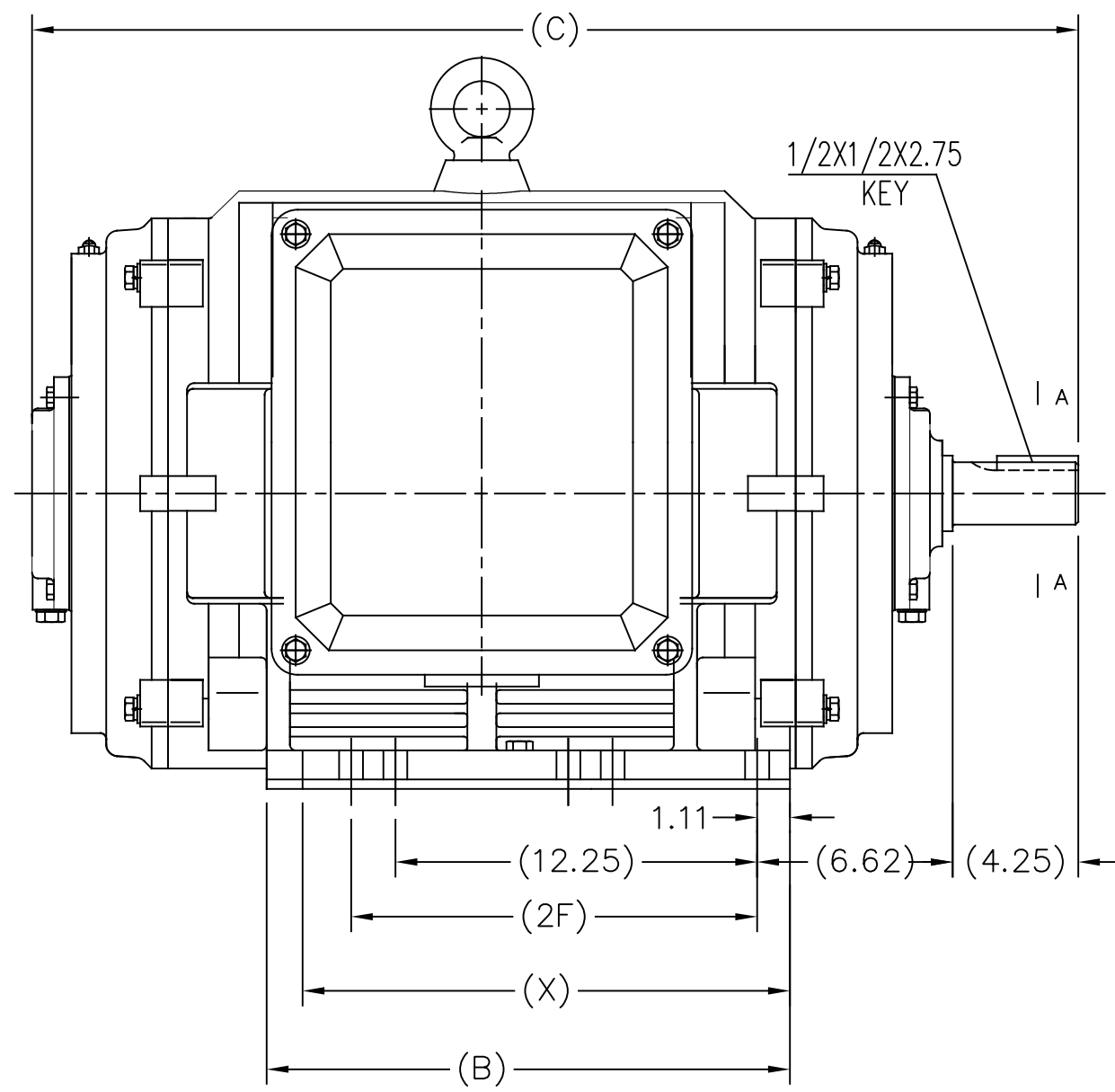

F2 MOUNTING

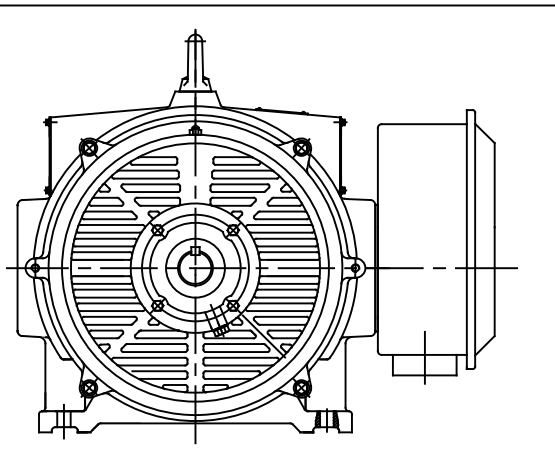

**PRELIMINARY**

404TS	33.86	16.22	N/A	15.00
405TS	35.44	17.72	13.75	16.50
Frame	C	B	2F	X

TOLERANCES UNLESS SPECIFIED		REGAL REGAL-BELOIT CORPORATION		DRAWN C.OHRMUNDT	
DEC.	INCHES			CHK	
.X	±.1	TITLE OUTLINE 404/405 TS FR - ODP - CAST IRON MAT'L. FINISH		APPD	SCALE NONE
.XX	±.03			REF	FMF WUXI
.XXX	±.005			PREV	
.XXXX	±.0005				
NO.	REVISION	BY & DATE	CHK	ANG	±7'30"
THIS DRAWING IN DESIGN AND DETAIL IS OUR PROPERTY AND MUST NOT BE USED EXCEPT IN CONNECTION WITH OUR WORK ALL RIGHTS OF DESIGN AND INVENTION ARE RESERVED THIS IS AN ELECTRONICALLY GENERATED DOCUMENT - DO NOT SCALE THIS PRINT			RFP	CAD FILE SS620752-SKT	
			DIST	SIZE B	DRAWING NO. PAGE 1 OF 1 REV. SS620752-SKT

EE7341C

THREE PHASE – PART WINDING START  
DELTA – 6 LEADS

START

CONNECT T1 TO LINE 1  
CONNECT T2 TO LINE 2  
CONNECT T3 TO LINE 3  
T7-T8-T9 OPEN

RUN

CONNECT T1&T7 TO LINE 1  
CONNECT T2&T8 TO LINE 2  
CONNECT T3&T9 TO LINE 3

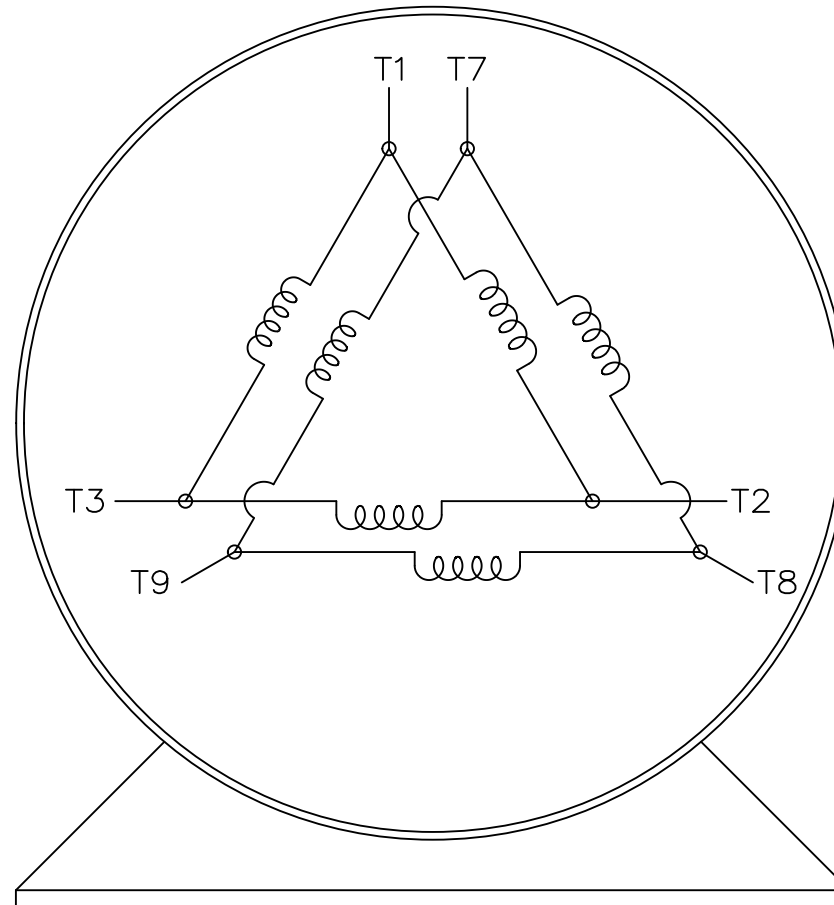

VIEW OF TERMINAL END

IF MOTOR HAS 2 T'S

START

CONNECT T1,T1 TO LINE 1  
CONNECT T2,T2 TO LINE 2  
CONNECT T3,T3 TO LINE 3  
T7,T7-T8,T8-T9,T9 OPEN

RUN

CONNECT T1,T1&T7,T7 TO LINE 1  
CONNECT T2,T2&T8,T8 TO LINE 2  
CONNECT T3,T3&T9,T9 TO LINE 3

		TOLERANCES UNLESS SPECIFIED		REGAL REGAL-BELOIT CORPORATION		DRAWN	BLR	03-09-1998
		DEC.	INCHES			CHK	ML	03-23-1998
		.X	± -			APPD	GK	03-23-1998
		.XX	± -	TITLE		SCALE 1=1		
E	NOTE ADDED FOR 2 T'S	NAR 17-12-2020	RC	.XXX	± -	CONNECTION DIAGRAM		REF
D	RE-DRAWN WITH REGAL LOGO ECO-0110493	WGJ 09-30-2016	EMH	.XXXX	± -	3ø - 6 LEADS		FMF
NO.	REVISION	BY & DATE	CHK	ANG	± -	FINISH		PREV
THIS DRAWING IN DESIGN AND DETAIL IS OUR PROPERTY AND MUST NOT BE USED EXCEPT IN CONNECTION WITH OUR WORK ALL RIGHTS OF DESIGN AND INVENTION ARE RESERVED THIS IS AN ELECTRONICALLY GENERATED DOCUMENT - DO NOT SCALE THIS PRINT			RFP	CAD FILE EE7341C		SIZE	DRAWING NO. PAGE OF REV.	
			DIST			A	EE7341C	E

**CERTIFICATION DATA SHEET**

**Model#:** 405TSTDCD6007 AA      **WINDING#:** HE32502009 NONE 1  
**CONN. DIAGRAM:** EE7341C      **ASSEMBLY:** F1/F2 CAPABLE  
**OUTLINE:** SS620752

**TYPICAL MOTOR PERFORMANCE DATA**

HP	KW	SYNC. RPM	F.L. RPM	FRAME	ENCLOSURE	KVA CODE	DESIGN
150&125	112&93	3600	3575&2972	405TS	DP	F	B

PH	Hz	VOLTS	FL AMPS	START TYPE	DUTY	INSL	S.F	AMB°C	ELEVATION
3	60/50	460#380	165&167	PWS OR INVERTER	CONTINUOUS	F7	1.15/1.15	40	3300

FULL LOAD EFF: 94.1&94.1	3/4 LOAD EFF: 94.1	1/2 LOAD EFF: 93.6	GTD. EFF	ELEC. TYPE	NO LOAD AMPS
FULL LOAD PF: 90&90	3/4 LOAD PF: 88.5	1/2 LOAD PF: 83	93.6	SQ CAGE INV RATED	44

F.L. TORQUE	LOCKED ROTOR AMPS	L.R. TORQUE	B.D. TORQUE	F.L. RISE°C
220 LB-FT	1040	387 LB-FT 175	553 LB-FT 250	40

SOUND PRESSURE @ 3 FT.	SOUND POWER	ROTOR WK^2	MAX. WK^2	SAFE STALL TIME	STARTS /HOUR	APPROX. MOTOR WGT
80 dBA	90 dBA	17 LB-FT^2	140 LB-FT^2	10 SEC.	2	1100 LBS.

**\*\*\* SUPPLEMENTAL INFORMATION \*\*\***

DE BRACKET TYPE	ODE BRACKET TYPE	MOUNT TYPE	ORIENTATION	SEVERE DUTY	HAZARDOUS LOCATION	DRIP COVER	SCREENS	PAINT
STANDARD	STANDARD	RIGID	HORIZONTAL	FALSE	NONE	FALSE	NONE	BLUE (ENAMEL)

BEARINGS		GREASE	SHAFT TYPE	SPECIAL DE	SPECIAL ODE	SHAFT MATERIAL	FRAME MATERIAL
DE	OPE						
BALL	BALL	POLYREX EM	TS	NONE	NONE	1045 HOT ROLLED (C-204)	CAST IRON
6313	6313						

THERMO-PROTECTORS				THERMISTORS	CONTROL	SPACE /n HEATERS
THERMOSTATS	PROTECTORS	WDG RTDs	BRG RTDs			
NONE	NOT	NONE	NONE	NONE	FALSE	NONE VOLTS

If Inverter equals NONE, contact factory for further information

\*  
N  
O  
T  
E  
S  
\*

INVERTER TORQUE: VARIABLE 10:1
INV. HP SPEED RANGE: NONE
ENCODER: NONE
NONE NONE
NONE NONE PPR
BRAKE: NONE NONE
NONE P/N NONE
NONE NONE
NONE FT-LB NONE V NONE Hz

DATE: 07/03/2017 01:59:24 AM  
 FORM 3531 REV.3 02/07/99  
 \*\* Subject to change without notice.

Data Sheet

Date: 12/1/2021  
 Customer: \_\_\_\_\_  
 Attention: \_\_\_\_\_  
 Submitted by: \_\_\_\_\_



405TSTDCD6007

Submittal

Data @ 460 V

Motor Load Data

Load	0%	25%	50%	75%	100%	115%	125%	LR
Current (Amps)	44.0	59.5	90.0	126	165	190	208	1,040
Torque (ft-lb)	0.00	55.0	110	165	220	255	276	400
RPM	3600	3595	3590	3582	3575	3,572	3568	0
Efficiency (%)		91.0	93.6	94.1	94.1	94.1	93.6	
P.F. (%)	7.0	65.0	83.0	88.5	90.0	90.0	90.0	68.0

Motor Speed Data

	LR	Pull-Up	BD	Rated	Idle
Speed (RPM)	0	1800	3460	3575	3600
Current (Amps)	1,040	830	350	165	44.0
Torque (ft-lb)	400	325	620	220	0.00

Information Block				
HP	150.0			
Sync. RPM	3600			
Frame	405			
Enclosure	DP			
Construction	TDC			
Voltage	460#380 V			
Frequency	60 Hz			
Design	B			
LR Code letter	F			
Service Factor	1.15			
Temp Rise @ FL	40 ° C			
Duty	CONT			
Ambient	40 ° C			
Elevation	3,300 feet			
Rotor/Shaft wk <sup>2</sup>	17.0 Lb-F <sup>2</sup>			
Ref Wdg	HA32502009 NONE			
Sound Pressure @ 1M	80 dBA			
VFD Rating	VARIABLE 20:1			
Outline Dwg	SS620752-200			
Conn. Diag	EE7341C			
Additional Specifications:				
0				
0				
EQUIV CKT (OHMS / PHASE)				
R1	R2	X1	X2	Xm
0.0260	0.0120	0.1610	0.1760	6.0670

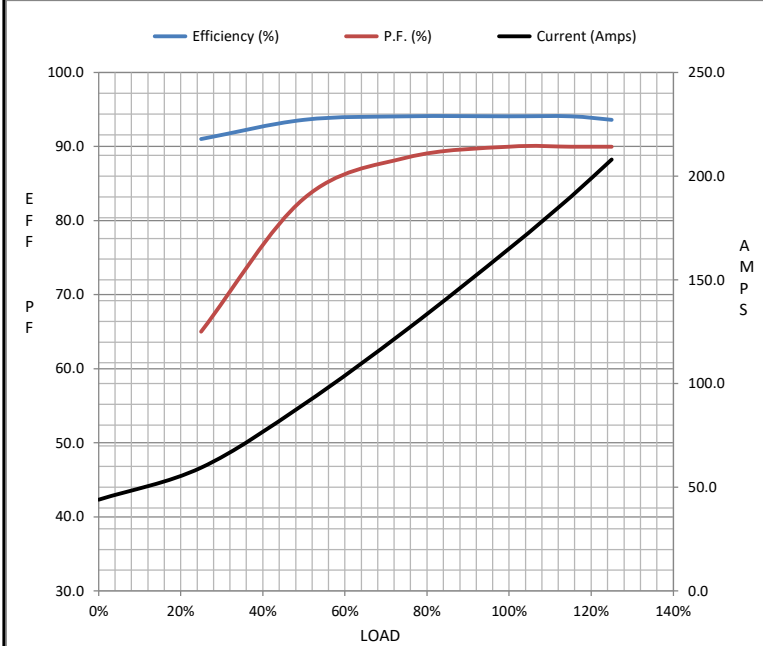

Speed - Torque Curve

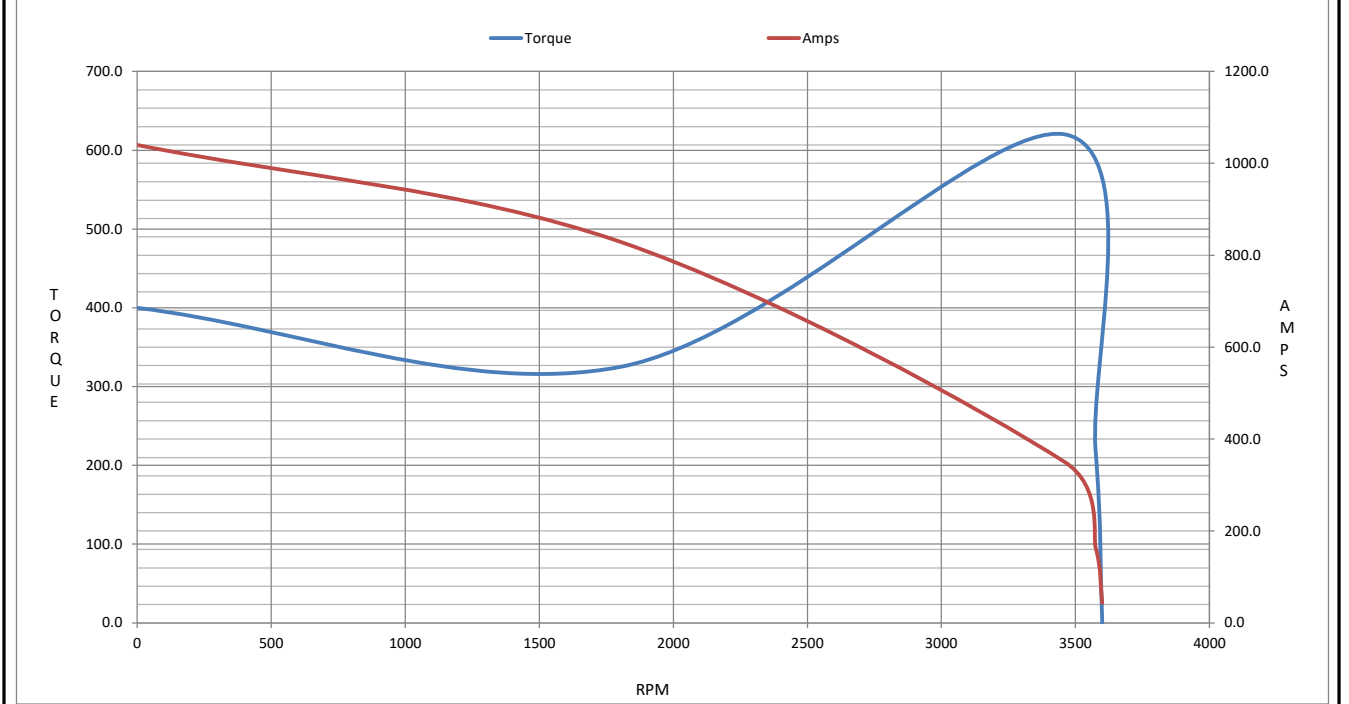

## EC Declaration of Conformity

The undersigned representing  
the manufacturer:

Regal Beloit America  
100 East Randolph St.  
Wausau, WI 54401

and the authorized representative  
established within the Community:

Marathon Electric UK  
6F Thistleton Road Ind. Estate  
Market Overton  
Oakham, Rutland LE15 7PP UK

are committed to providing customers with products that comply with applicable regulations and international protocols to which they are subject, including the requirements of the European Parliament Directive on the Harmonization of the laws relating to electrical equipment designed for use within certain voltage limits (2014/35/EU).

Regal Beloit America declares that the following product(s), to which this declaration relates, are in conformity with the relevant sections of the EC standards listed below.

This statement supersedes any statements previously issued pertaining to the product(s) listed below and is subject to change without notice.

Model No : 405TSTDCD6007

(Model No. may contain prefix and/or suffix characters)

Catalog No : GT0051A

Rework No : N/A

Directives :

Low Voltage Directive 2014/35/EU

Harmonized Standards Used :

EN 60034-1: 2010 (IEC 60034-1: 2010)

EN 60034-5: 2001/A1:2007 (IEC 60034-5: 2000/A1:2006)

Authorized Representative:



Michael A. Logsdon  
Vice President, Technology

Authorized Representative in the Community:



Julian Clark  
Marketing Engineer

Created on 09/01/2022

**CE 22**