

PRODUCT INFORMATION PACKET

Model No: 405TSHFS9026
Catalog No: W599
100 HP Severe Duty Motor, 3 phase, 1800 RPM, 460 V, 405TS Frame, TEFC
Severe Duty Motors



Regal and Marathon are trademarks of Regal Rexnord Corporation or one of its affiliated companies.
©2021 Regal Rexnord Corporation, All Rights Reserved. MC017097E



Nameplate Specifications

Output HP	100 Hp	Output KW	75.0 kW
Frequency	60 Hz	Voltage	460 V
Current	113.0 A	Speed	1780 rpm
Service Factor	1.15	Phase	3
Efficiency	95.4 %	Power Factor	87
Duty	Continuous	Insulation Class	F
Design Code	B	KVA Code	F
Frame	405TS	Enclosure	Totally Enclosed Fan Cooled
Thermal Protection	No	Ambient Temperature	40 °C
Drive End Bearing Size	6313	Opp Drive End Bearing Size	6313
UL	Recognized	CSA	Y
CE	Y	IP Code	56
Number of Speeds	1		

Technical Specifications

Electrical Type	Squirrel Cage Inverter Rated	Starting Method	Line Or Inverter
Poles	4	Rotation	Reversible
Resistance Main	.054 Ohms	Mounting	Rigid Base
Motor Orientation	Horizontal	Drive End Bearing	Ball
Opp Drive End Bearing	Ball	Frame Material	Cast Iron
Shaft Type	TS	Overall Length	34.13 in
Frame Length	16.75 in	Shaft Diameter	2.125 in
Shaft Extension	4.5 in	Assembly/Box Mounting	F1/F2 Capable
Connection Drawing	A-EE7300	Outline Drawing	B-SS509125-1675

This is an uncontrolled document once printed or downloaded and is subject to change without notice. Date Created:10/12/2021

**THREE PHASE - SINGLE VOLTAGE
MOTOR - CONDUIT BOX @ 'A'**

**TO REVERSE ROTATION:
INTERCHANGE ANY TWO
LINE LEAD CONNECTIONS.**

TERMINAL BLOCK WHEN SPECIFIED



VIEW OF TERMINAL END

**IF MOTOR HAS
6 LEADS**

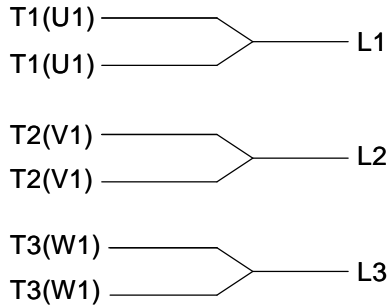

A-9806 DECAL

**OPTIONAL CORD
CONNECTION**

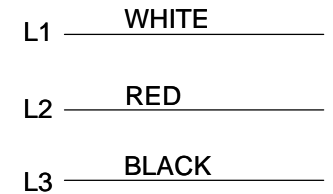

DRAWING REVISION AB	REVISION BY JJB	DATE 06-27-2017
ECO ECO-0125361	APPROVED BY TB	DATE 06-27-2017
ECO DESCRIPTION UPDATED TO CURRENT STANDARDS		
<small>COPYRIGHT REGAL BELOIT AMERICA, INC. ALL RIGHTS RESERVED. PROPRIETARY AND CONFIDENTIAL INFORMATION - THIS DOCUMENT IS THE PROPERTY OF REGAL BELOIT AMERICA, INC. ("OWNER") AND CONTAINS OWNER'S PROPRIETARY INFORMATION. ANY PERSON, CORPORATION OR OTHER FIRM RECEIVING IT IS DEEMED, BY RECEIVING IT, TO AGREE THAT IT, AND/OR ANY PART OF IT, SHALL NOT BE DISCLOSED TO ANY PERSON, CORPORATION OR OTHER ENTITY, DUPLICATED, AND/OR USED, EXCEPT AS EXPRESSLY APPROVED IN WRITING IN ADVANCE BY OWNER. THIS DOCUMENT SHALL BE RETURNED TO OWNER UPON REQUEST. IT MAY BE SUBJECT TO CERTAIN RESTRICTIONS UNDER APPLICABLE EXPORT CONTROL LAWS AND REGULATIONS.</small>		



DRAWN BY DA
DATE 03-26-1993
APPROVED BY TB
DATE 03-26-1993
REFERENCE
THIRD ANGLE PROJECTION

Regal Beloit America, Inc.	
DESCRIPTION CONNECTION DIAGRAM EXTERNAL - SINGLE VOLTAGE - 3Ø MOTOR	
MATERIAL	PROCESS/FINISH
SIZE A	DRAWING NUMBER EE7300
SHEET 1 OF 1	

Data Sheet

Date: 15-06-2017
Customer: _____
Attention: _____
Submitted by: FAREEDA DUDEKULA



405TSHFS9026

Submittal

Data @ **460 V**

Motor Load Data

Load	0%	25%	50%	75%	100%	115%	125%	LR
Current (Amps)	28.0	39.0	60.0	84.5	113	130	142	675
Torque (ft-lb)	0.00	73.0	147	221	295	341	370	445
RPM	1800	1795	1790	1785	1780	1,775	1770	0
Efficiency (%)		94.5	95.8	95.8	95.4	95.0	94.5	
P.F. (%)	4.5	64.0	81.5	86.0	87.0	87.5	87.5	28.0

Motor Speed Data

	LR	Pull-Up	BD	Rated	Idle
Speed (RPM)	0	900	1675	1780	1800
Current (Amps)	675	610	370	113	28.0
Torque (ft-lb)	445	400	715	295	0.00

Information Block				
HP	100.0			
Sync. RPM	1800			
Frame	405			
Enclosure	TEFC			
Construction	TFS			
Voltage	460 V			
Frequency	60 Hz			
Design	B			
LR Code letter	F			
Service Factor	1.15			
Temp Rise @ FL	75 ° C			
Duty	CONT			
Ambient	40 ° C			
Elevation	1,000 feet			
Rotor/Shaft wk ²	27.0 Lb-Ft ²			
Ref Wdg	T405472 NONE			
Sound Pressure @ 1M	72 dBA			
VFD Rating	CONSTANT 2:1			
Outline Dwg	B-SS509125-1675			
Conn. Diag	A-EE7300			
Additional Specifications:				
0				
365THFS8036				
EQUIV CKT (OHMS / PHASE)				
R1	R2	X1	X2	Xm
0.0430	0.0280	0.2980	0.2780	9.2020

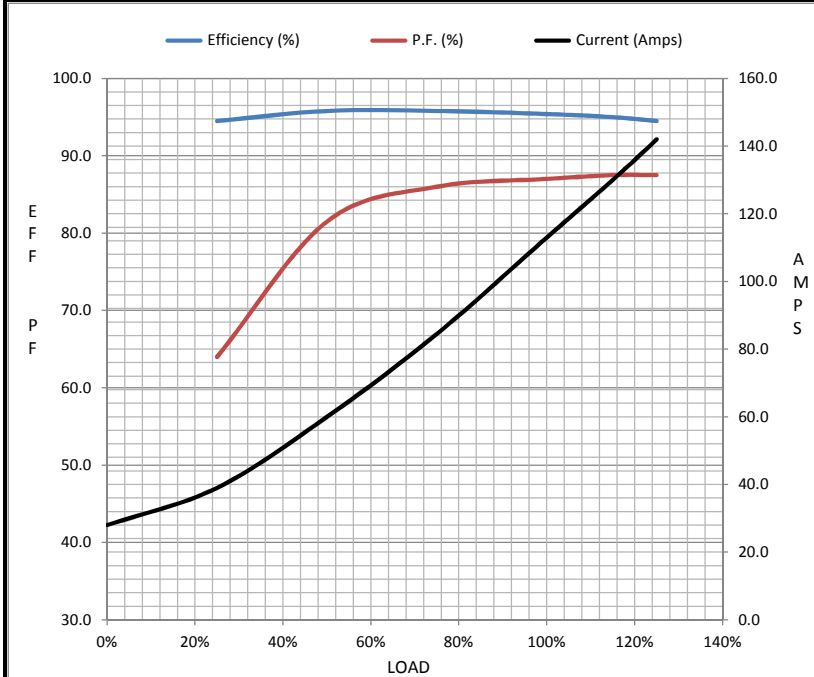

Speed - Torque Curve

