

PRODUCT INFORMATION PACKET

marathon®
Motors

Model No: 404TTFS4086

Catalog No: E803

Other Purpose Motor, 60 & 50 HP, 3 Ph, 60 & 50 Hz, 230/460 & 190/380 V, 1200 & 1000 RPM,
404T Frame, TEFC



Regal and Marathon are trademarks of Regal Rexnord Corporation or one of its affiliated companies.

©2023 Regal Rexnord Corporation, All Rights Reserved. MC017097E

RegalRexnord



Nameplate Specifications

Phase	3	Output HP	60 & 50 Hp
Output KW	45.0 & 37.0 kW	Voltage	230/460 & 190/380 V
Speed	1185 & 982 rpm	Service Factor	1.15 & 1.15
Frame	404T	Enclosure	Totally Enclosed Fan Cooled
Thermal Protection	No Protection	Efficiency	93.6 & 93 %
Ambient Temperature	40 °C	Frequency	60 & 50 Hz
Current	149/74.5 & 151/75.5 A	Power Factor	81
Duty	Continuous	Insulation Class	F
Design Code	B	KVA Code	G
Drive End Bearing Size	6316	Opp Drive End Bearing Size	6313
UL	Recognized	CSA	Y
CE	Y	IP Code	43
Number of Speeds	1		

Technical Specifications

Electrical Type	Squirrel Cage Induction Run	Starting Method	Across The Line
Poles	6	Rotation	Reversible
Resistance Main	.135 Ohms	Mounting	Rigid Base
Motor Orientation	Horizontal	Drive End Bearing	Ball
Opp Drive End Bearing	Ball	Frame Material	Cast Iron
Shaft Type	T	Overall Length	35.62 in
Frame Length	15.25 in	Shaft Diameter	2.880 in
Shaft Extension	7.5 in	Assembly/Box Mounting	F1/F2 CAPABLE
Outline Drawing	B-SS504699-1525	Connection Drawing	A-EE7308

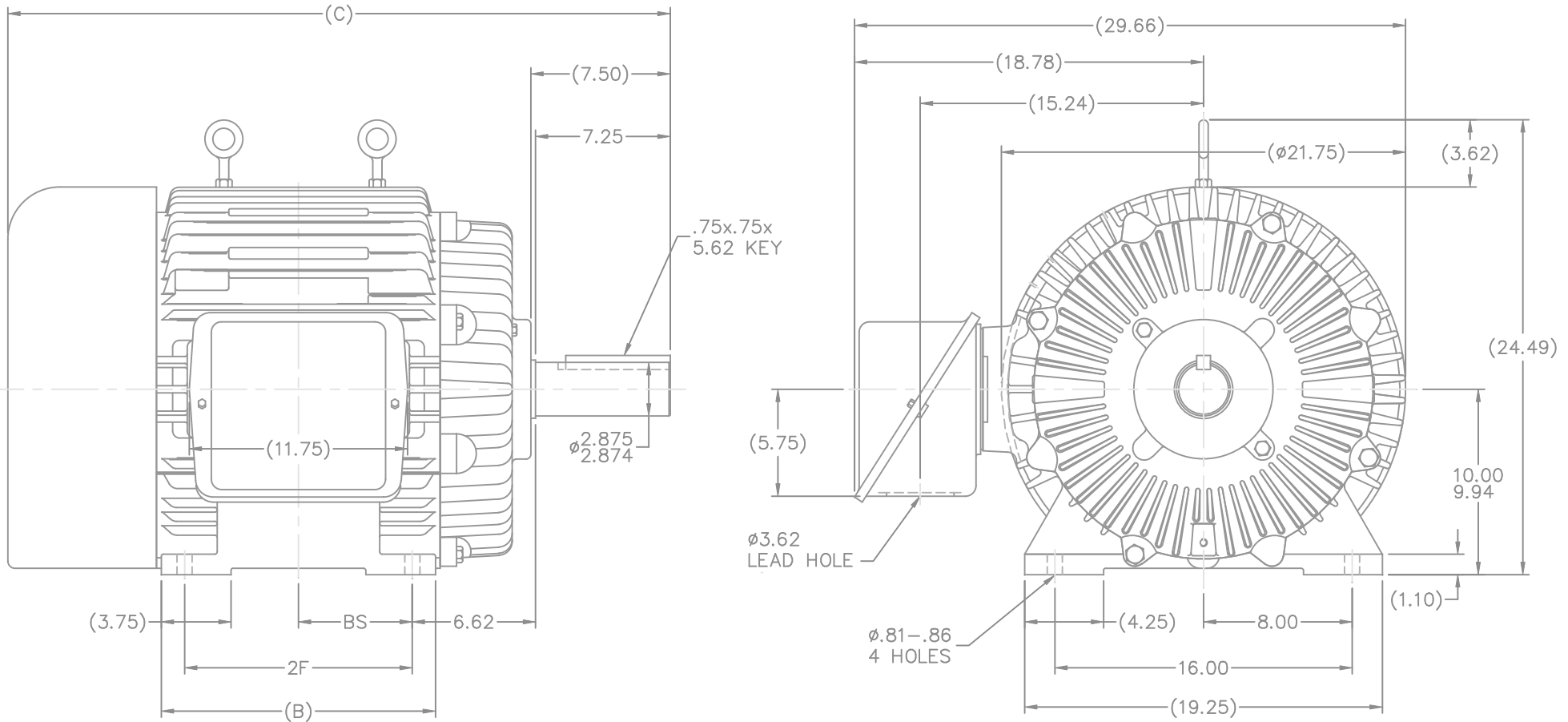

NOTES:

1. CONDUIT BOX CAN BE ROTATED IN 90° STEPS.
2. CONDUIT BOX CAN BE MOUNTED ON OPPOSITE SIDE BY REMOVING BRACKETS AND TURNING FRAME 180°.
3. NAMEPLATE TO BE READ FROM CONDUIT BOX SIDE OF MOTOR

DASH	FRAME	B	C	2F	BS
1525	404T	14.75	35.62	12.25	6.12

		TOLERANCES UNLESS SPECIFIED		MARATHON ELECTRIC		DRAWN TLB 05-20-1988					
		DEC.	INCHES			CHK	FG 05-20-1988				
10	REDRAWN IN AUTOCAD	TAT	06-29-2004	ML	.X	±.1	APPD	ML 05-20-1988			
9	UPDATED FRAME AND EYEBOLTS	CN	27430	KL	08-23-2000	.XX	±.03	SCALE	3=16		
8	UPDATED C' BOX GEOMETRY	CN	27430	DRS	02-08-2000	.XXX	±.005	REF			
7	REDRAWN ON CADD	TLB	05-20-1988			.XXX	±.0005	FMF			
NO.	REVISION	BY & DATE		CHK	ANG	±'30"	FINISH	PREV			
THIS DRAWING IN DESIGN AND DETAIL IS OUR PROPERTY AND MUST NOT BE USED EXCEPT IN CONNECTION WITH OUR WORK ALL RIGHTS OF DESIGN AND INVENTION ARE RESERVED THIS IS AN ELECTRONICALLY GENERATED DOCUMENT - DO NOT SCALE THIS PRINT				RFP	CAD FILE ss504699			SIZE	DRAWING NO.	PAGE OF	REV.
				DIST	WA			B	SS504699	10	



NO.	REVISION	BY & DATE	CHK	ANG	TOLERANCES UNLESS SPECIFIED		FINISH	DRAWN RM 11/20/1990				
					DEC.	INCHES						
5	CHG TO REGAL LOGO	SL 09/10/2015	AB					CHK ML 11/21/1990				
4	REVISED IEC NOTATIONS	MSG 11/15/2011	CMN	.X	±.1			APPD SAS 04/24/2003				
3	ADDED IEC NOTATIONS... (U1), (V1) ETC. MU95194	MSG 5/10/2010	MJS	.XX	±.02			SCALE 1=1				
2	ADDED THE OPTIONAL CORD CONNECTION MU46318	RDH 04/24/2003	DRS	.XXX	±.005		TITLE CONNECTION DIAGRAM 3Ø - DUAL VOLTAGE MOTOR	REF				
1	REDRAWN	RM 11/20/1990		.XXXX	±.0005		MAT'L.	FMF				
					±7'30"			PREV				
THIS DRAWING IN DESIGN AND DETAIL IS OUR PROPERTY AND MUST NOT BE USED EXCEPT IN CONNECTION WITH OUR WORK ALL RIGHTS OF DESIGN AND INVENTION ARE RESERVED THIS IS AN ELECTRONICALLY GENERATED DOCUMENT - DO NOT SCALE THIS PRINT							RFP	CAD FILE ee7308	SIZE A	DRAWING NO. EE7308	PAGE OF 5	REV. 5
							DIST WP					

CERTIFICATION DATA SHEET

Model#: 404TTFS4086 BR **WINDING#:** T404638 NONE 1
CONN. DIAGRAM: A-EE7308 **ASSEMBLY:** F1/F2 CAPABLE
OUTLINE: B-SS504699-1525

TYPICAL MOTOR PERFORMANCE DATA

HP	KW	SYNC. RPM	F.L. RPM	FRAME	ENCLOSURE	KVA CODE	DESIGN
60&50	45&37	1200	1185&982	404T	TEFC	G	B

PH	Hz	VOLTS	FL AMPS	START TYPE	DUTY	INSL	S.F	AMB°C	ELEVATION
3	60/50	230/460#190/ 380	149/74.5&151/ 75.5	ACROSS THE LINE	CONTINUOU S	F1	1.15/1.15	40	3300

FULL LOAD EFF: 93.6&93	3/4 LOAD EFF: 93.6	1/2 LOAD EFF: 93	GTD. EFF	ELEC. TYPE	NO LOAD AMPS
FULL LOAD PF: 81&81	3/4 LOAD PF: 76	1/2 LOAD PF: 65	92.4	SQ CAGE IND RUN	64 / 32

F.L. TORQUE	LOCKED ROTOR AMPS	L.R. TORQUE	B.D. TORQUE	F.L. RISE°C
266 LB-FT	870 / 435	550 LB-FT 207	700 LB-FT 263	75

SOUND PRESSURE @ 3 FT.	SOUND POWER	ROTOR WK^2	MAX. WK^2	SAFE STALL TIME	STARTS /HOUR	APPROX. MOTOR WGT
68 dBA	78 dBA	35.5 LB-FT^2	1200 LB-FT^2	20 SEC.	2	1150 LBS.

***** SUPPLEMENTAL INFORMATION *****

DE BRACKET TYPE	ODE BRACKET TYPE	MOUNT TYPE	ORIENTATION	SEVERE DUTY	HAZARDOUS LOCATION	DRIP COVER	SCREENS	PAINT
STANDARD	STANDARD	RIGID	HORIZONTAL	FALSE	NONE	FALSE	NONE	BLUE (ENAMEL)

BEARINGS		GREASE	SHAFT TYPE	SPECIAL DE	SPECIAL ODE	SHAFT MATERIAL	FRAME MATERIAL
DE	OPE						
BALL	BALL	POLYREX EM	T	NONE	NONE	1045 HOT ROLLED (C-204)	CAST IRON
6316	6313						

THERMO-PROTECTORS				THERMISTORS	CONTROL	SPACE /n HEATERS
THERMOSTATS	PROTECTORS	WDG RTDs	BRG RTDs			
NONE	NOT	NONE	NONE	NONE	FALSE	NONE VOLTS

If Inverter equals NONE, contact factory for further information

INVERTER TORQUE: NONE
INV. HP SPEED RANGE: NONE
ENCODER: NONE
NONE NONE
NONE NONE PPR
BRAKE: NONE NONE
NONE P/N NONE
NONE NONE
- FT-LB NONE V NONE Hz

*
N
O
T
E
S
*

DATE: 06/21/2017 08:05:26 AM
 FORM 3531 REV.3 02/07/99
 ** Subject to change without notice.

Data Sheet

Date: 12/13/2018
 Customer: _____
 Attention: _____
 Submitted by: FAREEDA DUDEKULA



404TTFS4086

Submittal

Data @ 460 V

Motor Load Data

Load	0%	25%	50%	75%	100%	115%	125%	LR
Current (Amps)	32.0	36.5	46.0	59.0	74.5	84.0	91.0	435
Torque (ft-lb)	0.00	66.0	132	200	266	300	334	550
RPM	1200	1195	1192	1188	1185	1,182	1178	0
Efficiency (%)		89.5	93.0	93.6	93.6	93.0	92.4	
P.F. (%)	4.5	43.0	65.0	76.0	81.0	82.5	83.0	40.0

Motor Speed Data

	LR	Pull-Up	BD	Rated	Idle
Speed (RPM)	0	600	1125	1185	1200
Current (Amps)	435	400	275	74.5	32.0
Torque (ft-lb)	550	525	700	266	0.00

Information Block

HP	60.0			
Sync. RPM	1200			
Frame	404			
Enclosure	TEFC			
Construction	TFS			
Voltage	230/460#190/380 V			
Frequency	60 Hz			
Design	B			
LR Code letter	G			
Service Factor	1.15			
Temp Rise @ FL	75 °C			
Duty	CONT			
Ambient	40 °C			
Elevation	1,000 feet			
Rotor/Shaft wk ²	35.5 Lb-Ft ²			
Ref Wdg	T404638 NONE			
Sound Pressure @ 1M	68 dBA			
VFD Rating	NONE			
Outline Dwg	B-SS504699-1525			
Conn. Diag	A-EE7308			
Additional Specifications:				
0				
0				
EQUIV CKT (OHMS / PHASE)				
R1	R2	X1	X2	Xm
0.0920	0.0520	0.3520	0.4070	7.8750

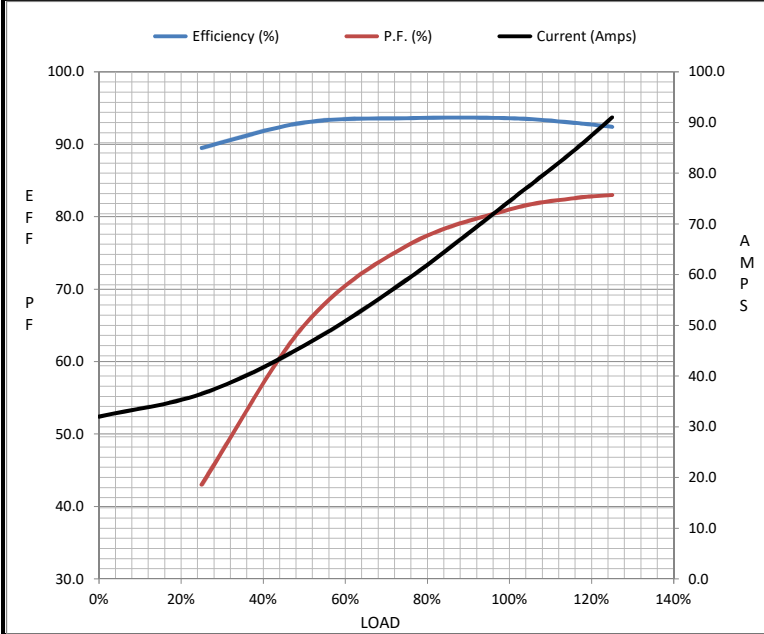

Speed -Torque Curve

