

PRODUCT INFORMATION PACKET

marathon®
Motors

Model No: 365TTGS4091

Catalog No: U092

Other Purpose Motor, 50 & 40 HP, 3 Ph, 60 & 50 Hz, 230/460 & 190/380 V, 1200 & 1000 RPM,
365T Frame, EPFC



Regal and Marathon are trademarks of Regal Rexnord Corporation or one of its affiliated companies.

©2023 Regal Rexnord Corporation, All Rights Reserved. MC017097E

RegalRexnord



Nameplate Specifications

Phase	3	Output HP	50 & 40 Hp
Output KW	37.0 & 30.0 kW	Voltage	230/460 & 190/380 V
Speed	1182 & 982 rpm	Service Factor	1.15 & 1.15
Frame	365T	Enclosure	Explosion Proof Fan cooled
Thermal Protection	Thermostat	Efficiency	93 & 92.4 %
Ambient Temperature	40 °C	Frequency	60 & 50 Hz
Current	127/63.5 & 124/62 A	Power Factor	79
Duty	Continuous	Insulation Class	F
Design Code	B	KVA Code	G
Drive End Bearing Size	6314	Opp Drive End Bearing Size	6312
UL	No	CSA	N
CE	N	IP Code	54
Number of Speeds	1	Hazardous Location	EXP PROOF CL I GR C&D CL II GR F&G T3B

Technical Specifications

Electrical Type	Squirrel Cage Inverter Rated	Starting Method	Line Or Inverter
Poles	6	Rotation	Reversible
Resistance Main	.135 Ohms	Mounting	Rigid Base
Motor Orientation	Horizontal	Drive End Bearing	Ball
Opp Drive End Bearing	Ball	Frame Material	Cast Iron
Shaft Type	T	Overall Length	32.74 in
Frame Length	14.50 in	Shaft Diameter	2.380 in
Shaft Extension	6.12 in	Assembly/Box Mounting	F1 ONLY
Connection Drawing	A-EE7308T	Outline Drawing	B-SS518459-1450

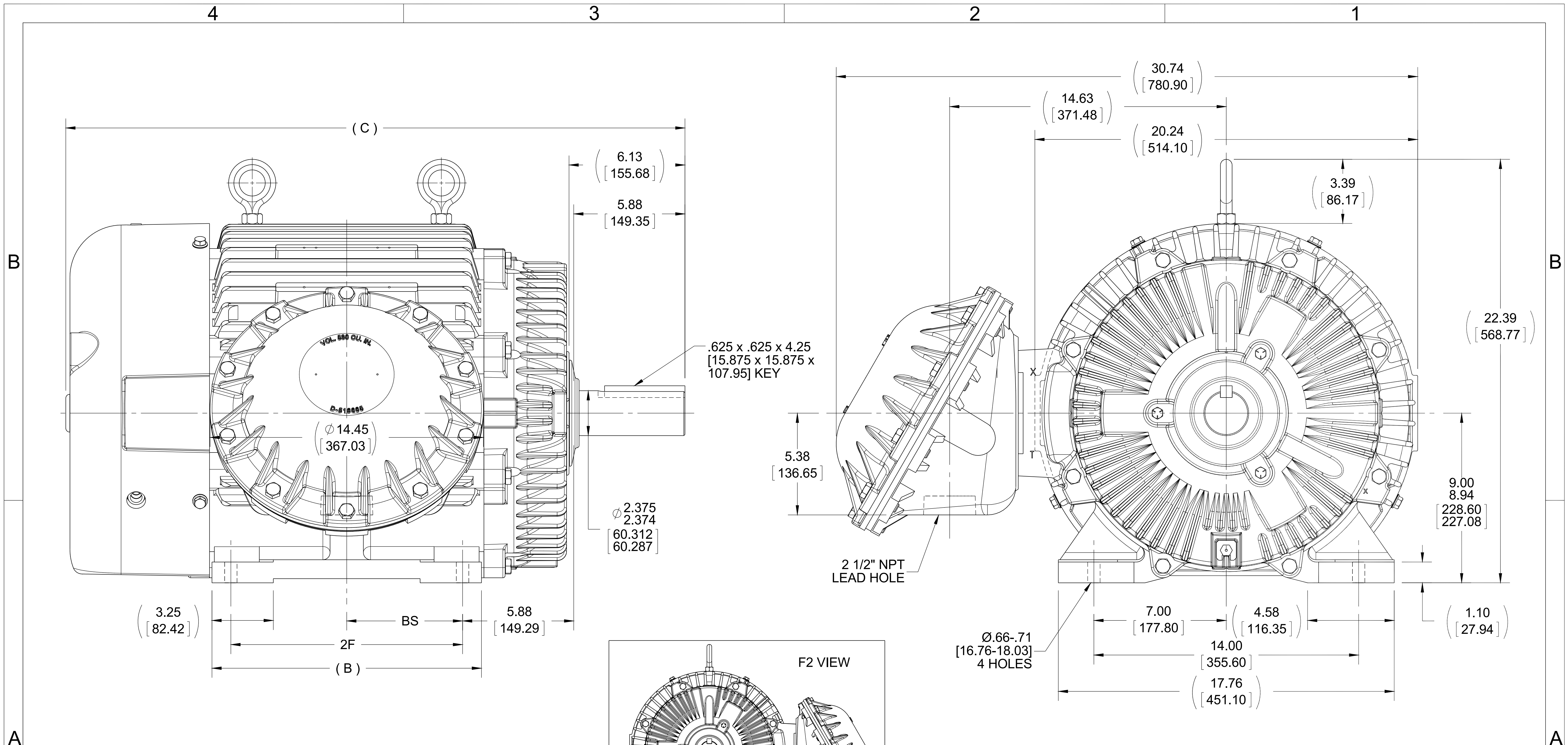

- NOTES:
 1. CONDUIT BOX CAN BE ROTATED IN 90° STEPS.
 2. CONDUIT BOX CAN BE MOUNTED ON OPPOSITE SIDE BY REMOVING BRACKETS AND TURNING FRAME 180°.
 3. NAMEPLATES TO BE READ FROM CONDUIT BOX SIDE OF MOTOR.

DASH	FRAME	B	C	2F	BS
1350	364T	13.25 [336.55]	31.74 [806.20]	11.25 [285.75]	5.62 [142.75]
1450	365T	14.25 [361.95]	32.74 [831.60]	12.25 [311.15]	6.12 [155.45]

DRAWING REVISION G	REVISION BY TDB	DATE 07-28-2015
ECO ECO-0082089	APPROVED BY DJK	DATE 07-30-2015
ECO DESCRIPTION UPDATED TO CURRENT STD'S		
<small>COPYRIGHT REGAL BELOIT AMERICA, INC. ALL RIGHTS RESERVED. PROPRIETARY AND CONFIDENTIAL INFORMATION - THIS DOCUMENT IS THE PROPERTY OF REGAL BELOIT AMERICA, INC. ("OWNER") AND CONTAINS OWNER'S PROPRIETARY INFORMATION. ANY PERSON, CORPORATION OR OTHER FIRM RECEIVING IT IS DEEMED, BY RECEIVING IT, TO AGREE THAT IT, AND/OR ANY PART OF IT, SHALL NOT BE DISCLOSED TO ANY PERSON, CORPORATION OR OTHER ENTITY, DUPLICATED, AND/OR USED, EXCEPT AS EXPRESSLY APPROVED IN WRITING IN ADVANCE BY OWNER. THIS DOCUMENT SHALL BE RETURNED TO OWNER UPON REQUEST. IT MAY BE SUBJECT TO CERTAIN RESTRICTIONS UNDER APPLICABLE EXPORT CONTROL LAWS AND REGULATIONS.</small>		

TOLERANCES UNLESS OTHERWISE SPECIFIED:

DEC.	INCH	mm	ANGLE
.X	±0.1	[±2.5]	±7° 30"
.XX	±0.03	[±0.76]	
.XXX	±0.005	[±0.127]	
.XXXX	±0.0005	[±0.0127]	

REMOVE BURRS & BREAK SHARP EDGES: .003/.015 [0.076/.381] X 45°
 CORNER FILLETS: R.02 [0.51]
 MACHINED SURFACES: 200 INCH/mm 5.1
 mm SHOWN IN [BRACKETS]

DRAWN BY TJB
DATE 05-14-2001
APPROVED BY GK
DATE 09-07-2001
REFERENCE
THIRD ANGLE PROJECTION

REGAL™ Regal Beloit America, Inc.

DESCRIPTION
OUTLINE
360T FR. - EXP. PROOF

MATERIAL PROCESS/FINISH

SIZE **B** DRAWING NUMBER **SS518459** SHEET 1 OF 1

HIGH VOLTAGE



**THREE PHASE
DUAL VOLTAGE MOTOR**

THERMO-PROTECTORS
CONNECTED IN SERIES



NOTE FOR FACTORY USE ONLY:
TO SURGE TEST FOR COMMON CONNECT:
HIGH VOLT: CONNECT P1 TO T1
THEN P2 TO L1
LOW VOLT: CONNECT P1 TO T1 & T7,
THEN P2 TO L1

LOW VOLTAGE

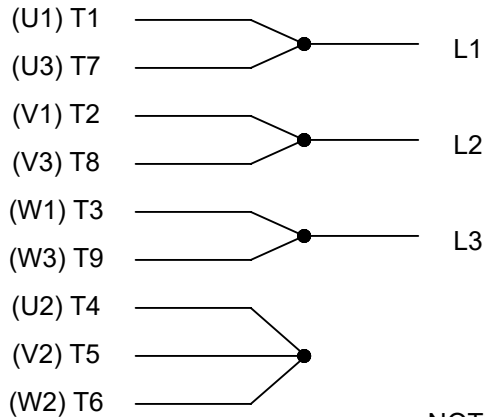

VIEW OF TERMINAL END

NOTE: LEAD'S COLOR CAN BE YELLOW OR WHITE FOR MT2 PLANT

DRAWING REVISION T	REVISION BY ZR	DATE 01-14-2019		DRAWN BY SMC	Regal Beloit America, Inc.
ECO ECO-0159915	APPROVED BY DR	DATE 01-15-2019		DATE 05-13-1992	
ECO DESCRIPTION ADDED TERMINAL CONNECTION DIAGRAM				APPROVED BY TB	DESCRIPTION CONN DIAGRAM-INTERNAL 3 PHASE - DUAL VOLTAGE MOTOR
<small>COPYRIGHT REGAL BELOIT AMERICA, INC. ALL RIGHTS RESERVED. PROPRIETARY AND CONFIDENTIAL INFORMATION - THIS DOCUMENT IS THE PROPERTY OF REGAL BELOIT AMERICA, INC. ("OWNER") AND CONTAINS OWNER'S PROPRIETARY INFORMATION. ANY PERSON, CORPORATION OR OTHER FIRM RECEIVING IT IS DEEMED, BY RECEIVING IT, TO AGREE THAT IT, AND/OR ANY PART OF IT, SHALL NOT BE DISCLOSED TO ANY PERSON, CORPORATION OR OTHER ENTITY, DUPLICATED, AND/OR USED, EXCEPT AS EXPRESSLY APPROVED IN WRITING IN ADVANCE BY OWNER. THIS DOCUMENT SHALL BE RETURNED TO OWNER UPON REQUEST. IT MAY BE SUBJECT TO CERTAIN RESTRICTIONS UNDER APPLICABLE EXPORT CONTROL LAWS AND REGULATIONS.</small>				DATE 05-13-1992	MATERIAL
			REFERENCE EE7308/EE7300	SIZE A	DRAWING NUMBER EE7308T

CERTIFICATION DATA SHEET

Model#: 365TTGS4091 AN **WINDING#:** T365670 NONE 1
CONN. DIAGRAM: A-EE7308T **ASSEMBLY:** F1 ONLY
OUTLINE: B-SS518459-1450

TYPICAL MOTOR PERFORMANCE DATA

HP	KW	SYNC. RPM	F.L. RPM	FRAME	ENCLOSURE	KVA CODE	DESIGN
50&40	37&30	1200	1182&982	365T	EPFC	G	B

PH	Hz	VOLTS	FL AMPS	START TYPE	DUTY	INSL	S.F	AMB°C	ELEVATION
3	60/50	230/460#190/ 380	127/63.5&124/ 62	LINE OR INVERTER	CONTINUOU S	F1	1.15/1.15	40	3300

FULL LOAD EFF: 93&92.4	3/4 LOAD EFF: 93	1/2 LOAD EFF: 92.4	GTD. EFF	ELEC. TYPE	NO LOAD AMPS
FULL LOAD PF: 79&79	3/4 LOAD PF: 73.5	1/2 LOAD PF: 62.5	91.7	SQ CAGE INV RATED	57 / 28.5

F.L. TORQUE	LOCKED ROTOR AMPS	L.R. TORQUE	B.D. TORQUE	F.L. RISE°C
222 LB-FT	710 / 355	400 LB-FT 180	550 LB-FT 248	75

SOUND PRESSURE @ 3 FT.	SOUND POWER	ROTOR WK^2	MAX. WK^2	SAFE STALL TIME	STARTS /HOUR	APPROX. MOTOR WGT
68 dBA	78 dBA	16.2 LB-FT^2	- LB-FT^2	- SEC.	-	1000 LBS.

***** SUPPLEMENTAL INFORMATION *****

DE BRACKET TYPE	ODE BRACKET TYPE	MOUNT TYPE	ORIENTATION	SEVERE DUTY	HAZARDOUS LOCATION	DRIP COVER	SCREENS	PAINT
STANDARD	STANDARD	RIGID	HORIZONTAL	TRUE	EXP PROOF CL I GR C&D CL II GR F&G T3B	FALSE	NONE	BLUE (EPOXY)

BEARINGS		GREASE	SHAFT TYPE	SPECIAL DE	SPECIAL ODE	SHAFT MATERIAL	FRAME MATERIAL
DE	OPE						
BALL	BALL	POLYREX EM	T	NONE	NONE	1045 HOT ROLLED (C-204)	CAST IRON
6314	6312						

THERMO-PROTECTORS				THERMISTORS	CONTROL	SPACE /n HEATERS
THERMOSTATS	PROTECTORS	WDG RTDs	BRG RTDs			
TSTATS (N/C)	NOT	NONE	NONE	NONE	FALSE	NONE VOLTS

If Inverter equals NONE, contact factory for further information

*
N
O
T
E
S
*

INVERTER TORQUE: CONSTANT 2:1 INV. HP SPEED RANGE: NONE
ENCODER: NONE NONE NONE NONE NONE PPR
BRAKE: NONE NONE NONE P/N NONE NONE NONE - FT-LB NONE V NONE Hz

DATE: 06/22/2017 03:35:27 AM
 FORM 3531 REV.3 02/07/99
 ** Subject to change without notice.

Data Sheet

Date: 12/12/2018
 Customer: _____
 Attention: _____
 Submitted by: FAREEDA DUDEKULA



365TTGS4091

Submittal

Data @ 460 V

Motor Load Data

Load	0%	25%	50%	75%	100%	115%	125%	LR
Current (Amps)	28.5	32.0	40.0	51.0	63.5	71.5	77.5	355
Torque (ft-lb)	0.00	55.0	110	166	222	256	280	400
RPM	1200	1195	1190	1185	1182	1,178	1175	0
Efficiency (%)		88.5	92.4	93.0	93.0	93.0	92.4	
P.F. (%)	4.5	41.0	62.5	73.5	79.0	80.5	81.0	33.0

Motor Speed Data

	LR	Pull-Up	BD	Rated	Idle
Speed (RPM)	0	600	1100	1182	1200
Current (Amps)	355	325	210	63.5	28.5
Torque (ft-lb)	400	350	550	222	0.00

Information Block

HP	50.0			
Sync. RPM	1200			
Frame	365			
Enclosure	EPFC			
Construction	TGS			
Voltage	230/460#190/380 V			
Frequency	60 Hz			
Design	B			
LR Code letter	G			
Service Factor	1.15			
Temp Rise @ FL	75 °C			
Duty	CONT			
Ambient	40 °C			
Elevation	1,000 feet			
Rotor/Shaft wk ²	16.2 Lb-Ft ²			
Ref Wdg	T365670 NONE			
Sound Pressure @ 1M	68 dBA			
VFD Rating	CONSTANT 2:1			
Outline Dwg	B-SS518459-1450			
Conn. Diag	A-EE7308T			
Additional Specifications:				
0				
0				
EQUIV CKT (OHMS / PHASE)				
R1	R2	X1	X2	Xm
0.0870	0.0710	0.4280	0.6010	9.0270

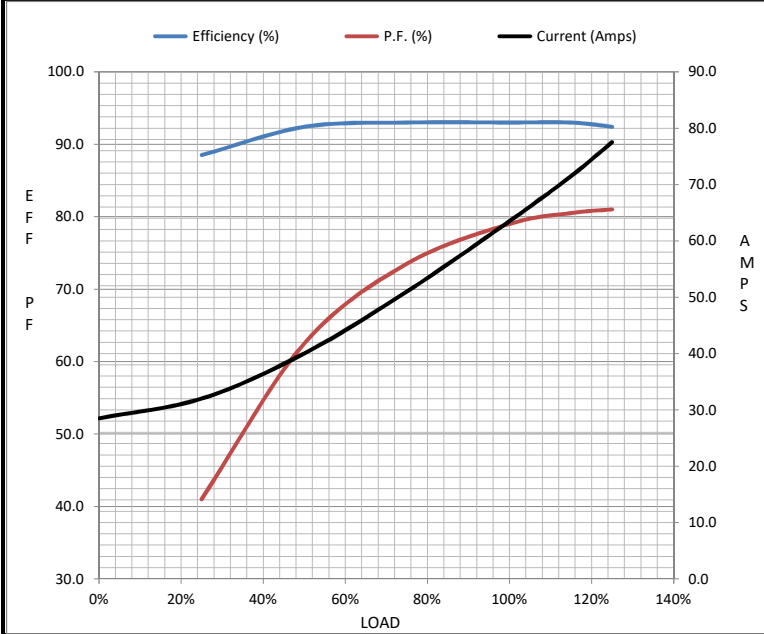

Speed - Torque Curve

