

PRODUCT INFORMATION PACKET

marathon[®]
Motors

Model No: 365TTFS4036

Catalog No: E957

Other Purpose Motor, 75 & 60 HP, 3 Ph, 60 & 50 Hz, 230/460 & 190/380 V, 1800 & 1500 RPM,
365T Frame, TEFC

Regal and Marathon are trademarks of Regal Rexnord Corporation or one of its affiliated companies.

©2023 Regal Rexnord Corporation, All Rights Reserved. MC017097E

RegalRexnord

Nameplate Specifications

Phase	3	Output HP	75 & 60 Hp
Output KW	56.0 & 45.0 kW	Voltage	230/460 & 190/380 V
Speed	1780 & 1480 rpm	Service Factor	1.15 & 1.15
Frame	365T	Enclosure	Totally Enclosed Fan Cooled
Thermal Protection	No Protection	Efficiency	94.1 & 94.1 %
Ambient Temperature	40 °C	Frequency	60 & 50 Hz
Current	178/89 & 172/86 A	Power Factor	84
Duty	Continuous	Insulation Class	F
Design Code	B	KVA Code	G
Drive End Bearing Size	6314	Opp Drive End Bearing Size	6312
UL	Recognized	CSA	Y
CE	Y	IP Code	43
Number of Speeds	1		

Technical Specifications

Electrical Type	Squirrel Cage Induction Run	Starting Method	Across The Line
Poles	4	Rotation	Reversible
Resistance Main	.073 Ohms	Mounting	Rigid Base
Motor Orientation	Horizontal	Drive End Bearing	Ball
Opp Drive End Bearing	Ball	Frame Material	Cast Iron
Shaft Type	T	Overall Length	32.52 in
Frame Length	14.50 in	Shaft Diameter	2.375 in
Shaft Extension	6.13 in	Assembly/Box Mounting	F1/F2 CAPABLE
Outline Drawing	B-SS504688-1450	Connection Drawing	A-EE7308K

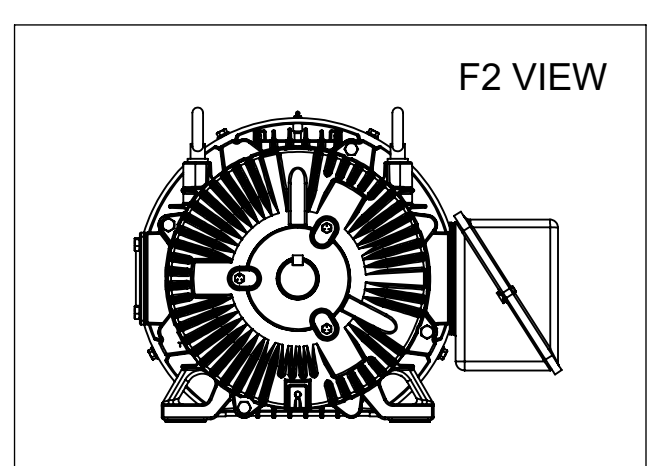
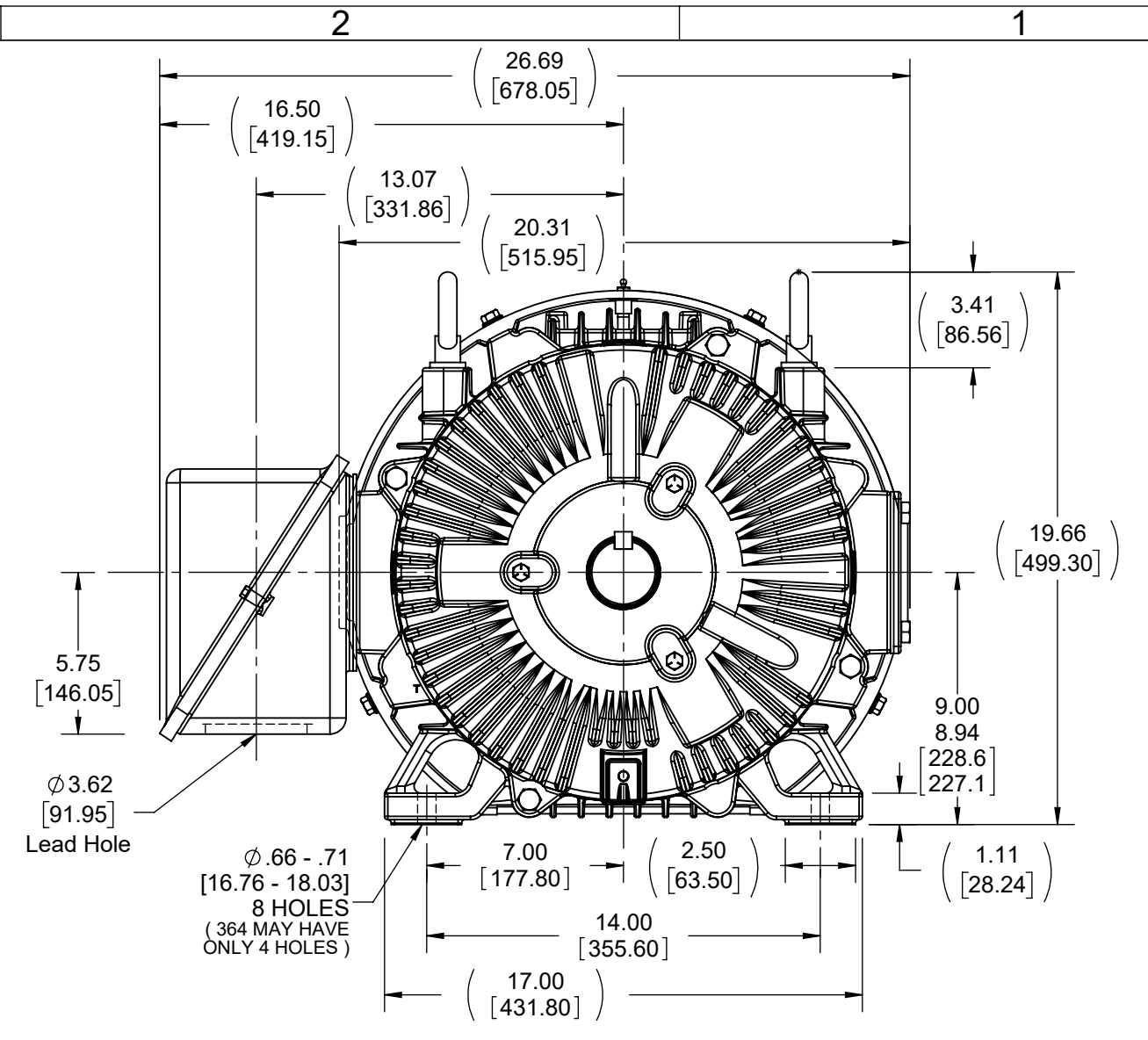
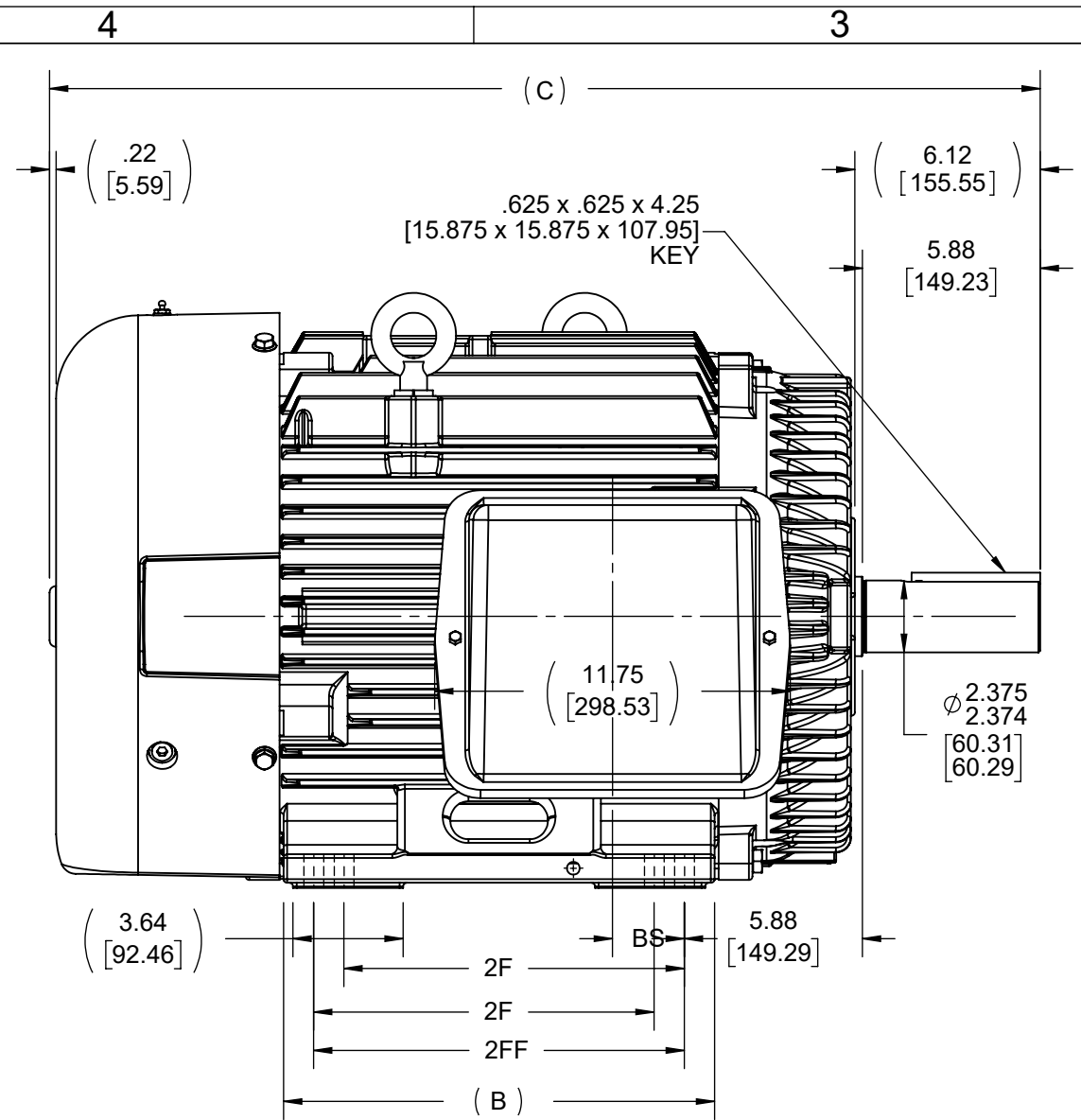

FRAME 364 - 1350

- NOTE:
 1. ALTERNATE FRAME DRAWING.
 2. MODELS USING ALTERNATE FRAME 553485A.

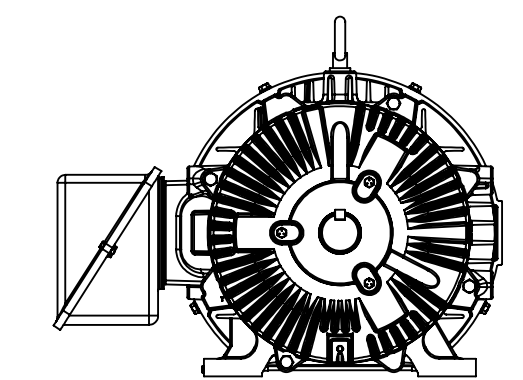
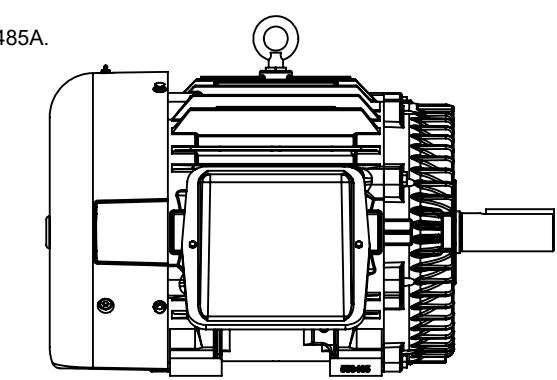

- NOTES:
 1. CONDUIT BOX CAN BE ROTATED IN 90° STEPS

DASH	FRAME	B	C	2F	2FF	BS
1350	364T	13.25 [336.55]	31.52 [800.61]	11.25 [285.75]	---	5.62 [142.75]
1450	364/365T	14.25 [361.95]	32.52 [826.01]	11.25 [285.75]	12.25 [311.15]	2.38 [60.45]

DRAWING REVISION E	REVISION BY MJ	REV DATE/© DATE 05/04/2022
REQUEST NUMBER CR-0007552	APPROVED BY VJ	DATE 05/04/2022
REQUEST NUMBER DESCRIPTION OUTLINE DRAWING IS UPDATED WITH NEW FRAME.		
<small>COPYRIGHT (PER REVISION DATE) REGAL BELOIT AMERICA, INC. ALL RIGHTS RESERVED. PROPRIETARY AND CONFIDENTIAL INFORMATION - THIS DOCUMENT IS THE PROPERTY OF REGAL BELOIT AMERICA, INC. ("OWNER") AND CONTAINS OWNER'S PROPRIETARY INFORMATION. ANY PERSON, CORPORATION OR OTHER FIRM RECEIVING IT IS DEEMED, BY RECEIVING IT, TO AGREE THAT IT, AND/OR ANY PART OF IT, SHALL NOT BE DISCLOSED TO ANY PERSON, CORPORATION OR OTHER ENTITY, DUPLICATED, AND/OR USED, EXCEPT AS EXPRESSLY APPROVED IN WRITING IN ADVANCE BY OWNER. THIS DOCUMENT SHALL BE RETURNED TO OWNER UPON REQUEST. IT MAY BE SUBJECT TO CERTAIN RESTRICTIONS UNDER APPLICABLE EXPORT CONTROL LAWS AND REGULATIONS.</small>		

TOLERANCES (EXCEPT AS NOTED):
 DEC. INCH mm ANGLE
 .X ±0.1 [±3] ±7° 30"
 .XX ±0.03 [±0.8]
 .XXX ±0.005 [±0.13]
 .XXXX ±0.0005 [±0.013]
 REMOVE BURRS & BREAK SHARP EDGES: .003/.015 [0.08/.38] X 45°
 CORNER FILLETS: R.02 [5]
 MACHINED SURFACES: 200 INCH/mm 5.1
 mm DIMENSIONS IN [BRACKETS] ARE FOR REFERENCE ONLY

DRAWN BY
TLB
 DATE
04-29-1998
 APPROVED BY
ML
 DATE
04-29-1988
 REFERENCE
 THIRD ANGLE PROJECTION

Regal Rexnord Regal Beloit America, Inc.

DESCRIPTION
OUTLINE
360T FR. - TEFC - (STD.)

MATERIAL PROCESS/FINISH

SIZE **B** DRAWING NUMBER **SS504688** SHEET 1 OF 1

LOW VOLTAGE



HIGH VOLTAGE



VIEW OF TERMINAL END

			TOLERANCES UNLESS SPECIFIED		 REGAL - BELOIT CORPORATION	DRAWN PGK 06-04-1997				
NO.	REVISION	BY & DATE	CHK	ANG		±	INCHES	CHK	ML 06-05-1997	
E	CORRECTED IEC MARKINGS ECD-0111208	WGJ 01-23-2017	EMH	DEC.				APPD	GK 06-15-1997	
D	RE-DRAWN WITH REGAL LOGO ECD-0110493	WGJ 09-30-2016	EMH	.X	±.1					
8	ADDED IEC DESIGNATIONS MU95020	TJW 4/30/2010	MJS	.XX	±.02		TITLE	SCALE		
7	REVISED HIGH VOLTAGE L2 WAS L3 CN52600-354	MRB 09-21-1998		.XXX	±.005		CONNECTION DIAGRAM	REF		
6	REDRAWN ON CADD	PGK 06-05-1997		.XXXX	±.0005		DELTA CON. - 3Ø - 9 LEADS	FMF		
					±7'30"		MAT'L.	PREV		
			RFP				FINISH			
THIS DRAWING IN DESIGN AND DETAIL IS OUR PROPERTY AND MUST NOT BE USED EXCEPT IN CONNECTION WITH OUR WORK ALL RIGHTS OF DESIGN AND INVENTION ARE RESERVED THIS IS AN ELECTRONICALLY GENERATED DOCUMENT - DO NOT SCALE THIS PRINT							CAD FILE EE7308K	SIZE	DRAWING NO. PAGE OF	REV.
							A	EE7308K	E	